



Science **made** smarter

Additional Information

Callisto™



D-0107239-R – 2024/10



Interacoustics

Table of Contents

1	AC440	1
1.1	About AC440 module	1
1.2	Launching AC440	2
1.2.1	Launching from OtoAccess®	2
1.2.2	Launching AC440 from Noah	2
1.2.3	Using the tone screen	3
1.3	The speech screen elements	9
1.3.1	Speech audiometry in graph mode	12
1.3.1.1	Dual speech graphs	13
1.3.1.2	50% Discrimination line	14
1.3.1.3	IEC dB hearing level scale	14
1.3.1.4	Bönningshaus & Röser calculation	16
1.3.2	Speech audiometry in table mode	17
1.3.2.1	The SRT table	17
1.3.2.2	The WR table	18
1.4	Binaural speech	19
1.5	Counselling tab	20
1.5.1	SoundStudio	20
1.6	Clinical application of the AC440 tests	21
1.6.1	High frequency audiometry	23
1.6.2	Multi frequency audiometry	24
1.6.3	Bone conduction audiometry	24
1.6.4	Masking	25
1.6.5	Speech audiometry	26
1.6.5.1	Speech reception threshold (SRT) in table mode	29
1.6.5.2	Word recognition (WR) in table mode	30
1.6.5.3	Speech testing with a microphone	31
1.6.5.4	Speech testing with wave files	32
1.6.6	Master hearing aid (MHA)	33
1.6.7	Hearing loss simulation (HLS)	34
1.6.8	Short increment sensitivity index	36
1.6.9	Weber	37
1.6.10	ABLB/Fowler	37
1.6.11	Stenger test	38
1.6.12	TEN test	40
1.6.13	QuickSIN	40
1.6.14	Tone decay	43
1.6.15	ANL test	46
1.6.16	SIQ test	51
1.6.17	SIN test	52
1.6.18	VDB-express	54
1.6.19	The Audible Contract Threshold (ACT™) Test	58
1.7	Working with individual setups (test protocols)	67
1.7.1	Selecting a test protocol:	67
1.7.2	Creating new protocols	68
1.7.2.1	Common setup	68
1.7.2.2	Tone testing setup	72
1.7.2.3	Speech testing setup	84
1.7.2.4	MHA counselling setup	92
1.7.2.5	HLS counselling setup	94
1.7.2.6	SISI testing setup	98

1.7.2.7	Weber testing setup.....	99
1.7.2.8	QuickSIN setup	100
1.7.2.9	ABLB/Fowler and Stenger setup	102
1.7.2.10	TEN test setup.....	102
1.7.2.11	ANL test setup.....	104
1.7.2.12	SIQ test setup.....	106
1.7.2.13	SIN test setup.....	108
1.7.2.14	VDB-express setup.....	110
1.7.3	Finishing the test protocol	112
1.7.4	Changing a test protocol permanently.....	113
1.7.5	Changing a test protocol temporarily	113
1.7.6	Importing and exporting test protocols	114
1.7.6.1	Importing a test protocol:	115
1.7.6.2	Exporting a test protocol:	116
1.8	General setup.....	117
1.8.1	Symbol editor	118
1.8.2	Noah database settings	119
1.8.3	Tone and speech settings	119
1.9	General suite settings and examiner	120
1.9.1	Start-up.....	120
1.9.2	Examiner settings	120
1.9.3	Languages	121
1.9.4	PDF print.....	122
1.10	Password protection.....	123
1.11	AC440 menu items	124
1.12	PC shortcut manager	126
1.13	Standalone database settings.....	127
1.14	View data without license	127
1.15	FAQ	129
1.16	Appendix 1	131
1.16.1	Audiometer implementation of the TEN(HL) test for diagnosing cochlear dead regions	131
1.17	Appendix 2	139
1.17.1	Masking help/automasking quick guide	139
1.18	Technical specifications of the AC440 software	142
1.18.1	Technical specifications of the AC440 software	142
2	REM440	144
2.1	Quick guide	144
2.2	About REM440	146
2.3	REM440 tests.....	146
2.4	Launching REM440.....	147
2.4.1	Launching REM440 from Noah:	147
2.4.2	Launching REM440 from OtoAccess®:	147
2.5	The REM screen elements.....	148
	Table View button provides a chart view of the measured and target values.	151
2.6	Background on real-ear measurements using REM440	156
2.6.1	Required items	156
2.6.2	Calibration.....	158
2.6.3	Gain versus response view	159
2.6.4	Real-ear measurements on open fittings	160
2.6.4.1	Calibrate for open fit	161
2.6.5	Probe placement.....	162
2.6.6	Stimuli for real-ear measures.....	163
2.6.6.1	Tone stimuli	163

	2.6.6.2	Speech stimuli/ISTS	163
	2.6.6.3	Composite signals/ICRA.....	163
	2.6.6.4	What stimulus to choose?	164
2.6.7		Referencing	165
2.6.8		Vocal effort.....	166
	2.6.8.1	Presenting a stimulus.....	167
2.6.9		Working with fitting targets	167
	2.6.9.1	Calculating the target	167
	2.6.9.2	Choosing a fitting prescription.....	168
	2.6.9.3	DSL <i>m</i> [i/o] options	168
	2.6.9.4	NAL-NL1/NAL-NL2 options	171
2.6.10		Comparing to the hearing aid fitting software.....	172
	2.6.10.1	On top mode.....	172
	2.6.10.2	Table mode.....	173
	2.6.10.3	Show cursor on the graph	173
2.6.1		Speech Intelligibility Index (SII)	173
2.6.2		Display peaks and valleys	175
2.6.3		Preconditioning and sweep delay	175
	2.6.3.1	Preconditioning	175
	2.6.3.2	Sweep delay	175
2.6.4		Smoothing a curve.....	176
2.6.5		Comparing curves	176
2.6.6		Managing multiple curves.....	177
	2.6.6.1	Curve display options.....	177
	2.6.6.2	Deleting curves	178
	2.6.6.3	Combined screen view.....	178
	2.6.6.4	Changing the curve color.....	178
2.7		Clinical application of real-ear measurements using REM440	179
	2.7.1	REUR/REUG measurements	179
		2.7.1.1 Predicted REUR.....	181
		2.7.1.2 REUG/REUR from a previous session.....	182
		2.7.1.3 REUR/REUG in both ears view	182
	2.7.2	REAR/REAG measurements	183
	2.7.3	REIG measurements.....	185
	2.7.4	RECD measurements	187
		2.7.4.1 RECD using the client's own ear mould.....	189
		2.7.4.2 RECD using the SPL probe	191
		2.7.4.3 Own mould versus SPL probe	193
		2.7.4.4 Predicted RECD curve	193
		2.7.4.5 Measured RECD compared to a predicted RECD.....	194
		2.7.4.6 Re-using a coupler curve.....	194
		2.7.4.7 RECD from a previous session.....	195
		2.7.4.8 Test box/coupler base fitting (simulated REM).....	195
		2.7.4.9 The "coupler approach".....	195
		2.7.4.10 The "real-ear approach".....	197
		2.7.4.11 Importing the RECD into the hearing aid manufacturers software.....	197
		2.7.4.12 Counselling the parents in visible speech mapping.....	197
	2.7.5	REOR/REOG measurements	198
	2.7.6	Measuring input/output	200
	2.7.7	Directionality measurements.....	201
	2.7.8	Binaural REM measurements.....	202
2.8		Working with individual setups (test protocols)	210
	2.8.1	Selecting a test protocol	210
	2.8.2	Creating new test protocols.....	211
		2.8.2.1 REUG/REUR settings	215

2.8.2.2	REAR/REAG settings.....	217
2.8.2.3	REIG settings	219
2.8.2.4	RECD settings.....	222
2.8.2.5	REOR/REOG settings.....	224
2.8.2.6	Input/output settings.....	226
2.8.2.7	Directionality settings	228
2.8.2.8	Pause settings.....	230
2.8.2.9	Visible speech mapping settings	230
2.8.3	Combined screen setup.....	231
2.8.4	Fitting prescription setup	232
2.8.4.1	DSL	233
2.8.4.2	NAL-NL2 settings.....	234
2.8.4.3	NAL-NL1 settings.....	235
2.8.4.4	Print layout settings	236
2.8.5	Finishing the test protocol	237
2.8.6	Changing a test protocol permanently.....	238
2.8.7	Changing a test protocol temporarily.....	239
2.8.8	Importing and exporting test protocols	239
2.8.8.1	Importing a test protocol	239
2.8.8.2	Exporting a test protocol.....	240
2.9	General setup.....	241
2.10	The REM 440 menu items	244
2.11	Visible speech mapping (VSPM440)	247
2.11.1	About visible speech mapping.....	247
2.12	The visible speech mapping screen.....	248
2.13	Verification with visible speech mapping	253
2.13.1	Considerations before you begin.....	253
2.13.2	Visible speech mapping (in ear mode).....	253
2.13.3	Visible speech mapping (in coupler mode/test box mode).....	255
2.14	Visual tools for counseling and verification	257
2.14.1	Percentile analysis.....	257
2.14.2	Display peaks and valleys	258
2.14.3	Show examples.....	258
2.14.4	Speech intelligibility index	259
2.14.5	Speech spectrum.....	259
2.14.6	Dynamic range view.....	260
2.14.7	Aided versus unaided	261
2.15	Visible speech mapping settings.....	262
2.16	FAQ	265
2.17	Appendix 1	271
2.18	The REM440 test signal characteristics.....	271
2.18.1	Signal analysis characteristics.....	272
	The following table summarises the signal analysis characteristics of the Callisto system.	272
2.19	REM PC shortcuts.....	273
2.20	REM software - technical specifications	274

3	HIT440.....	275
3.1	HIT440 quick guide	275
3.2	About HIT440	277
3.3	HIT 440 tests	278
3.4	Launching the HIT 440 software from databases	241
3.4.1	Launching HIT440 from Noah.....	241
3.4.2	Launching HIT440 from OtoAccess®.....	241
3.5	The HIT440 screen	242
3.6	Hearing instrument testing using HIT440.....	247

3.6.1	Testing hearing instruments:.....	247
3.6.2	Running pre-programmed test protocols.....	249
3.6.3	Automatic testing (auto run).....	249
3.6.4	Preconditioning and sweep delay	250
	3.6.4.1 Preconditioning	250
	3.6.4.2 Sweep delay	250
3.6.5	Smoothing a curve.....	250
3.6.6	Show cursor on the graph	251
	3.6.6.1 Managing multiple curves.....	251
	3.6.6.2 Curve display options.....	252
	3.6.6.3 Combined screen view.....	252
	3.6.6.4 Changing the curve color.....	252
3.6.7	Comparing curves	253
3.6.8	Comparing to the manufacturer's specification sheets	254
3.7	Application of the HIT440 tests	255
3.7.1	Frequency response	255
3.7.2	Gain curve	256
3.7.3	Harmonic distortion	257
3.7.4	Input/output.....	258
3.7.5	Intermodulation distortion	259
3.7.6	Attack/recovery time.....	260
3.7.7	Equivalent input noise.....	261
3.7.8	Reference test gain	262
3.7.9	Microphone directionality.....	263
3.7.10	Single frequency	264
3.7.11	Response/gain/input/output	265
3.7.12	OSPL90.....	266
3.7.13	Full-on gain.....	267
3.8	Working with individual setups (test protocols)	268
3.8.1	Selecting a (standard) test protocol:.....	268
3.8.2	Designing a customized test protocol.....	269
	3.8.2.1 Frequency response settings.....	271
	3.8.2.2 Gain curve settings.....	275
	3.8.2.3 Harmonic distortion settings.....	276
	3.8.2.4 Input/output settings.....	278
	3.8.2.5 Intermodulation distortion settings	280
	3.8.2.6 Attack/recovery time settings	282
	3.8.2.7 Equivalent input noise settings	284
	3.8.2.8 Reference test gain settings.....	287
	3.8.2.9 Directionality settings	289
	3.8.2.10 Single frequency settings	290
	3.8.2.11 Response/gain/input/output settings.....	292
	3.8.2.12 Delay settings.....	293
	3.8.2.13 Pause settings.....	294
3.8.3	Combined screen setup.....	295
3.8.4	Print layout settings	296
3.8.5	Finishing the test protocol	297
3.8.6	Changing a test protocol permanently.....	298
3.8.7	Changing a test protocol temporarily	299
	3.8.7.1 Importing and exporting test protocols	299
	3.8.7.2 Importing a test protocol	299
	3.8.7.3 Exporting a test protocol.....	300
3.9	General setup.....	301
3.10	The HIT440 menu items.....	304
3.11	HIT440 software - technical specifications.....	306

3.12	Appendix 1	307
3.12.1	The HIT440 test signal characteristics	307
3.13	Appendix 2:	308
3.13.1	Connecting the TBS10 to Callisto™	308
4	PRINTING AND MAKING REPORTS	313
4.1	The print wizard.....	313
4.1.1	Designing a customized print template	315
4.1.2	Design elements	316
4.1.2.1	General elements	316
4.1.3	Taskbar	320
4.2	Creating reports	321
4.2.1	Operation of the report editor.....	321
4.2.1.1	The report editor	321
4.2.1.2	The template editor.....	323
5	RECOVERY MANAGER.....	324
6	CRASH REPORTS.....	326
7	QUICK GUIDES.....	328
8	REFERENCES	329



1 AC440

1.1 About AC440 module

AC440 is the PC-based audiometry module for the Callisto™ hardware platform.

The AC440 software is an independent two-channel audiometer. It features tone audiometry for air and bone, speech testing and a variety of masking and signal types. Stimuli are presented using the PC keyboard, mouse, or a dedicated audiometry keyboard. Test results are displayed on screen and saved to the associated database (e.g., Noah, OtoAccess®). They are immediately available for inspection, hearing aid fitting, printout, export, and so on. The AC440 module can also be operated external to a database in stand-alone mode.

The module is flexible, enabling the individual clinician to tailor the system according to their specific preferences. It permits the creation of an unlimited number of personalized test protocol settings and functions for different purposes and/or for different clinicians working at the same location. The system also provides you with the option to make individual print layouts, keep reports electronically, and compare actual curves to previous sessions. These numerous setup options can be very helpful and time saving in the daily clinical work environment.

In addition to the setup functions, the AC440 also contains counselling tools to help both patient and relatives to get a better understanding of the consequences of hearing impairment and why hearing amplification may be needed.

The AC440 contains the following tests:

- Air Conduction Audiometry
 - High Frequency Audiometry
 - Multi Frequency audiometry
- Bone Conduction Audiometry
- Free Field Audiometry
- Speech Audiometry
- Master Hearing Aid (MHA) (counselling tool)
- Hearing Loss Simulation (HLS) (counselling tool)
- Short Increment Sensitivity Index (SISI)
- Weber
- Stenger
- Tone Decay Test
- TEN test
- QuickSIN



1.2 Launching AC440

Ensure that the Callisto™ is connected before opening the software suite. If the hardware is not detected the Callisto™ Suite will run in Simulation mode.

Simulation mode is indicated by this indicator in the lower left corner of the software Suite.

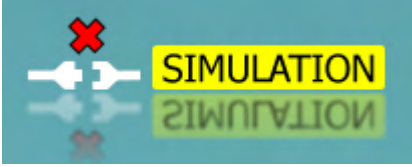

1.2.1 Launching from OtoAccess®

For further instructions about working with OtoAccess®, please see the OtoAccess® operation manual.

1.2.2 Launching AC440 from Noah

If you are using HIMSA's Noah 4, the Callisto™ Suite software will install itself automatically in the menu bar on the start page, along with all the other software modules.

For further instructions about working with Noah, please see the Noah operation manual.



1.2.3 Using the tone screen

The following section describes the elements of the tone screen.

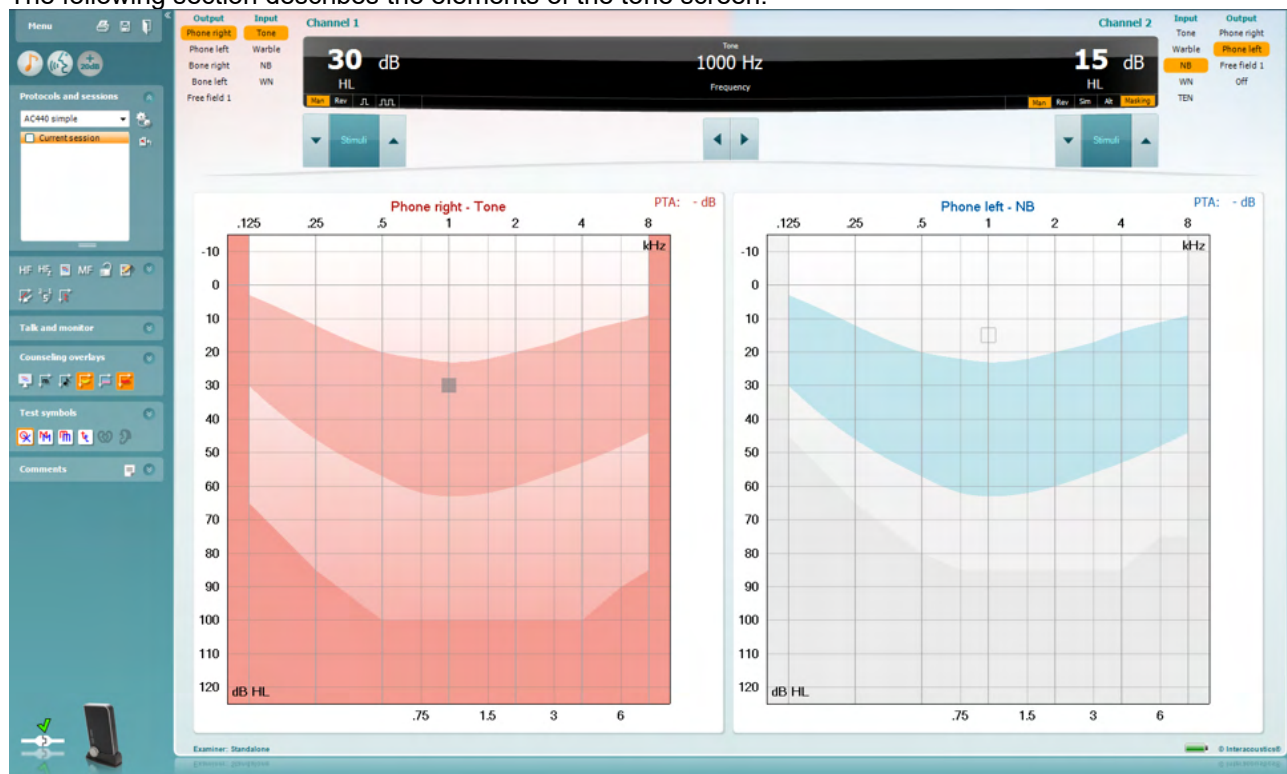

Menu provides access to Print, Edit, View, Tests, Setup, and Help



Print allows for printing the session's acquired data.



Save & New Session saves the current session in Noah or OtoAccess® and opens a new one.



Save & Exit saves the current session in Noah or OtoAccess® and exits the Suite.



Collapse the left side panel.



Go to Tone Audiometry activates the tone screen when in another test.



Go to Speech Audiometry activates the speech screen when in another test.



Extended Range +20 dB extends the testing range and can be activated when the testing dial setting gets within 50 dB of the maximum level of the transducer.

Note that the extended range button will flash when it needs activation for reaching higher intensities.



To switch on the extended range automatically, select the **Switch extended range on automatically** by going to the setup menu.



Fold an area so that it only shows the label or the buttons of that area.



Unfold an area so that all buttons and labels are visible

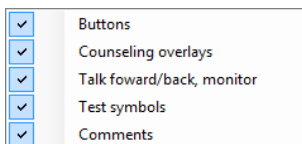

Show/hide areas can be found by right mouse clicking on one of the areas. The visibility of the different areas as well as the space that they take on the screen is locally saved to the examiner.



List of Defined Protocols allows for selecting a test protocol for the current test session. Please refer to section 1.6 for more information about protocols. Right mouse click on a protocol allows the current examiner to set or deselect a default start-up protocol.



Temporary Setup allows for making temporary changes to the selected protocol. The changes will be valid for the current session only. After making the changes and returning to the main screen, the name of the protocol will be followed by an asterisk (*).

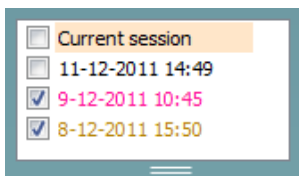

List of historical sessions accesses historical sessions for comparison purposes. The audiogram of the selected session, indicated by the orange background, is shown in colors as defined by the used symbol set. All other audiograms that are selected by check marks show on screen in the colors as indicated by the text color of the date and time stamp. Note that this listing can be resized by dragging the double lines up or down.

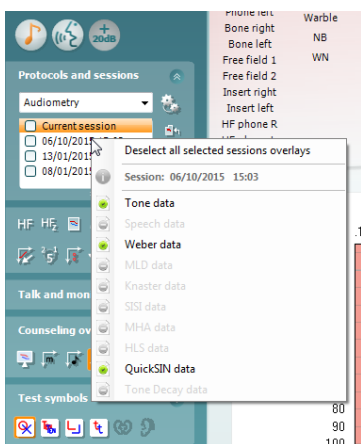

Right Clicking on a historical session will allow you to see exactly which measurements have been performed in that session. This is useful when trying to find a special test amongst several sessions without opening the session individually to find the data you need.

The tests which have been performed will have a green light next to them.

You can also click on **Deselect all selected sessions overlays** after right clicking on the sessions to remove any historic session overlays you have chosen to display.



Go to Current Session brings you back to the current session.



High Frequency¹ shows frequencies on the audiogram (up to 16 kHz for the Callisto™). However, you will only be able to test in the frequency range the selected headset is calibrated for.



High Frequency Zoom activates high frequency testing and zooms in on the high frequency range.

¹ HF requires an additional license for the AC440. If not purchased, the button is grayed out.



 Single audiogram

Single audiogram toggles between viewing the information of both ears in a single graph and two separate graphs.

MF Multi frequencies

Multi frequencies² activate testing with frequencies in between the standard audiometric test frequencies. The frequency be adjusted in the AC440 setup.

 Synchronize channels

Synchronize channels locks the two channels together. This function may be used to perform synchronous masking.

 Edit mode

Edit Mode button activates the editing function. Left clicking on the graph will add/move a point to the position of the cursor. By right clicking on a point, it is possible to **Delete** the recorded point or the entire curve. Furthermore, right mouse click provides the option to **Add unmasked threshold, Add no response, Add masked threshold, Add masked-no-response threshold, Copy bone thresholds to other ear,** and **Hide unmasked thresholds where masked exist.**

 Mouse controlled audiometry

Mouse controlled audiometry enables you to do the audiometry using the mouse only. The stimulus is presented with the left mouse button, and the threshold is stored with the right mouse button.

 dB step size

The **dB step size** button indicates to which dB step size increment the system is currently set. It rotates from 1 to 2 to 5 dB and the larger number indicates the setting.

 Hide unmasked thresholds

The **hide unmasked threshold** will hide those unmasked thresholds where masked thresholds exist.

 Toggle masking help

Toggle Masking Help will activate or deactivate the Masking Help. The masking help function can be removed from this interface through amending the settings in the Protocol Setup (See this in section 1.7.2.2).

For more information on Masking Help, please see section 1.7.2.2 or Appendix 4 for the Masking Help Quick Guide

 Toggle automasking

Toggle Automasking will activate or deactivate the Automasking feature.

For more information on Automasking, please refer to section 1.7.2.2 or to Appendix 4 for the Masking Help Quick Guide.

Talk forward  60
-20 dB 0 +3 dB

Talk Forward activates the Talk Forward microphone. The arrow keys can be used to set the talk forward level through the currently selected transducers. The level will be accurate when VU meter indicates to be at zero dB.

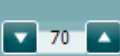
Monitor
 Ch1 Ch2  70

Selecting the **Monitor Ch1** and/or **Ch2** check boxes allow you to monitor one or both channels through an external loudspeaker/headset connected to the monitor input. The monitor intensity is adjusted by the arrow keys.

Talk back  0

The **Talk back** check box enables you to listen to the patient. Note that you need to be equipped with a microphone connected to the talk back input and an external loudspeaker/headset connected to the monitor input.

² MF requires an additional license for the AC440. If not purchased, the button is greyed out.



Patient monitor

The **Patient monitor** opens an always-on-top window with the tone audiograms and all its counselling overlays shown. This provides an easier layout to counsel the patient. The size and position of the patient monitor gets saved for each examiner individually.



Phonemes

The **Phonemes** counselling overlay shows phonemes as it is configured in the protocol that is currently in use.



Sound examples

The **Sound examples** counselling overlay shows pictures (png-files) as they are set up in the protocol that is currently in use.



Speech banana

The **Speech banana** counselling overlay shows the speech area as it is set up in the protocol that is currently in use.



Severity

The **Severity** counselling overlay shows the degrees of hearing loss as it is set up in the protocol that is currently in use.



Max. testable values

The **Max. testable values** overlay highlights the area beyond the maximum intensity that the system allows. This reflects the transducer calibration and differs when the extended range is activated.

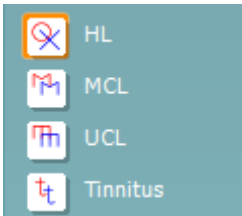

HL

MCL

UCL

Tinnitus

Selecting **HL**, **MCL**, **UCL** or **Tinnitus** sets the symbol types that are currently in use by the audiogram for different tests. HL stands for hearing level, MCL stands for most comfortable level and UCL stands for uncomfortable level. Note that these buttons display the unmasked right and left symbols of the currently selected symbol set.

Each type of measurement is saved as a separate curve.



Binaural

Aided

Binaural and **Aided** allows for indicating if the test is performed with hearing aids or binaurally with corresponding symbols. The measurements will be saved as separate curves.

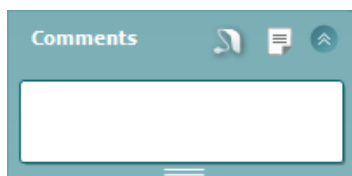

Comments

In the **Comments** section you can type comments related to any audiometric test. The used space by the comments area can be set by

dragging the double line with your mouse. Pressing the  button opens a separate window for adding notes to the current session. The report editor and comment box contain the same text. In case the formatting of the text is important, this can only be set within the report editor.

On pressing the  button you will see a menu which allows you to specify the hearing aid style on each ear. This is just for note taking when performing aided measurements on your patient.

After saving the session, comment changes can only be made within the same day until the date changes (at midnight). **Note:** these timeframes are limited by HIMSA and the Noah software and not by Interacoustics.



Output	Input
Phone right	Tone
Phone left	Warble
Bone right	NB
Bone left	WN
Free field 1	

The **Output** list for channel 1 provides the option to test through head phones, bone conductor or free field speakers. Note that the system only shows the calibrated transducers. Insert Phones can be added in place of the head phone if plugged into the Callisto™.

The **Input** list for channel 1 provides the option to select pure tone, warble tone, narrow band noise (NB) and white noise (WN).

Note that the background shading is according to the side that is selected, red for right and blue for left.

Input	Output
Tone	Phone right
Warble	Phone left
NB	Free field 1
WN	Off
TEN	

The **Output** list for channel 2 provides the option to test through head phones, bone conductor, free field speakers or to turn the channel off. Note that the system only shows the calibrated transducers. Insert Phones can be added in place of the head phone if plugged into the Callisto™.

The **Input** list for channel 2 provides the option to select pure tone, warble tone, narrow band noise (NB), white noise (WN) and TEN noise³.

Note that the background shading is according to the side that is selected, red for right, blue for left, and white when off.



Man and **Rev** allows toggling between Manual and Reverse test modes. In manual the stimulus is presented only when manually activated. In reverse the signal is presented continuously until interrupted by the tone switch.



Pulsation allows for single and continuous pulsating presentation. The duration of the stimulus can be adjusted in the AC440 setup.



Sim/Alt allows toggling between Simultaneous and Alternate presentation. Ch1 and Ch2 will present the stimulus simultaneously when Sim is selected. When Alt is selected, the stimulus will alternate between Ch1 and Ch2.



Masking indicates if channel 2 is currently in use as a masking channel and in that way makes sure masking symbols are used in the Audiogram. For example, in paediatric testing through free field speakers, channel 2 can be set as a second testing channel. Note that a separate store function for channel 2 is available when channel 2 is not used for masking.



dB HL Increase and **Decrease** buttons allow increasing/decreasing the intensities of channel 1 and 2.

The arrow keys on the PC keyboard can be used for increasing/decreasing channel 1 intensities.

PgUp and PgDn on the PC keyboard can be used for increasing/decreasing channel 2 intensities.



Stimuli buttons will light up when hovering the mouse over it. This indicates the presentation of a stimulus.

A right mouse click in the Stimuli area will store a no response threshold. A left mouse click in the Stimuli area will store the threshold at the current position.

Channel 1 stimulation can also be obtained by pressing the space bar or left Ctrl key on the PC keyboard.

³ TEN noise requires an additional license for the AC440. If not purchased, the stimulus is not available.



Channel 2 stimulation can also be obtained by pressing the right Ctrl key on the PC keyboard.

Mouse movements in the Stimuli area for both channel 1 and channel 2 can be ignored depending on the setup.

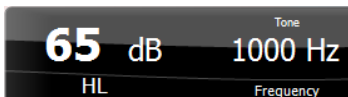

Frequency and Intensity display area shows what is currently presented. To the left the dB HL value for channel 1 is shown and to the right for channel 2. In the centre the frequency is displayed.

Notice that the dB dial setting will flash when trying to go louder than the maximum available intensity.

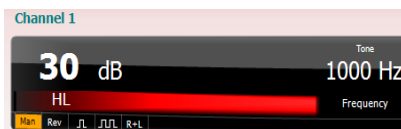

The patient response indicator will appear in between these values when the patient response button is depressed. The color of this indicator will depend upon which patient response side is used, a red light indicates the right patient response, and a blue light indicates the left patient response.



Frequency increase/decrease increases and decreases the frequency respectively. This can also be obtained using the left and right arrow keys on the PC keyboard.

Storing thresholds for channel 1 is done by pressing **S** or by a left mouse click in the attenuator of channel 1. Storing a no response threshold can be done by pressing **N** or by a right mouse click in the stimuli button of channel 1.

Storing thresholds for channel 2 is available when channel 2 is not the masking channel. It is done by pressing **<Shift> S** or by a left mouse click in the stimuli button of channel 2. Storing a no response threshold can be done by pressing **<Shift> N** or by a right mouse click in the attenuator of channel 2.



The hardware indication picture indicates whether the hardware is connected. **Simulation mode** is indicated when operating the software without hardware.

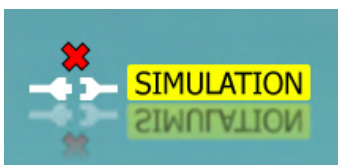

When opening the Suite, the system will automatically search for the hardware. If it does not detect the hardware, then the Suite will run in Simulation mode.



The **Examiner** indicates the current clinician who is testing the patient. The examiner is saved with a session and can be printed with the results. This information is taken from the login on the database from which the Suite is launched, or the suite can be configured in the 'General Suite Settings' to request an examiner name on start-up.



For each examiner, the Suite stores how it is set up with regards to the use of space in the screen. The examiner will find that the suite starts up looking the same as it did the last time, they used the software. Also, the examiner can select which protocol must be selected at start up (by right mouse click on the protocol selection list).



1.3 The speech screen elements

The following section describes the elements of the speech screen in addition to the tone screen:

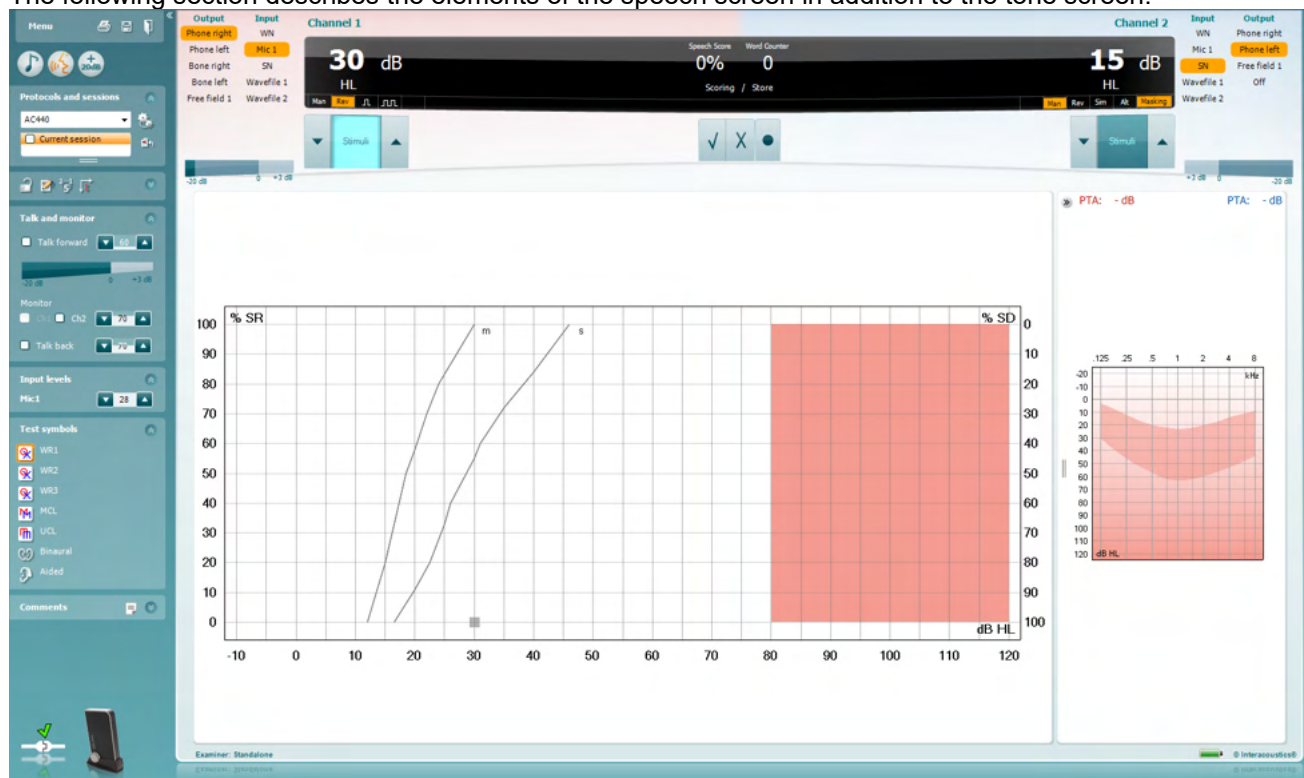

Input levels

Mic1 ▼ 28 ▲

Input levels adjuster allows you to adjust the input level to 0 VU for the Mic1 input. This ensures that correct calibration is obtained for Mic1. On the VU Meter the dial intensity is achieved when the signal is at the 0 mark.

WR1

WR3

WR2

WR1, WR2 and WR3 (Word Recognition) allows selecting different speech list setups as defined by the selected protocol. The labels of these lists which go along with these buttons can also be customized in the protocol setup. (See section 1.6.2.3).

Binaural

Aided

Binaural and **Aided** function allows for indicating if the test is performed binaurally or while the patient is wearing hearing aids.

Output	Input
Phone right	WN
Phone left	Mic 1
Bone right	SN
Bone left	Wavefile 1
Free field 1	Wavefile 2

The **Output** list for channel 1 provides the option to test through head phones, bone conductor or free field speakers. Note that the system only shows the calibrated transducers. Insert Phones can be added in place of the head phone if plugged into the Callisto™.

The **Input** list for channel 1 provides the option to select white noise (WN), speech noise (SN), microphone 1 (Mic1), wave file 1 and wavefile 2.

Note that the background shading of the speech Audiogram is according to the side that is selected, red for right and blue for left.



Input	Output
WN	Phone right
Mic 1	Phone left
SN	Free field 1
Wavefile 1	Off
Wavefile 2	

The **Output** list for channel 2 provides the option to test through head phones, free field speakers or to turn the channel off. Note that the system only shows the calibrated transducers. Insert Phones can be added in place of the head phone if plugged into the Callisto™. The **Input** list for channel 2 provides the option to select white noise (WN), speech noise (SN), microphone (Mic1 and Mic2) and wave file.

Note that the background shading is according to the side that is selected, red for right, blue for left, and white when off.

Speech Scoring:

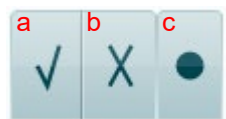

- a) **Correct:** A mouse click on this button will store the word as correctly repeated. The **left** arrow key can also be used for storing as correct.
- b) **Incorrect:** A mouse click on this button will store the word as incorrectly repeated. The **right** arrow key can also be used to score as incorrect.

*when using the graph mode, the correct/incorrect scoring is assigned by using the **Up** and **Down** arrow keys.
- c) **Store:** A mouse click on this button will store the speech threshold in the speech graph. A point can also be stored by pressing **S**.

Phoneme scoring:



- a) **Phoneme scoring:** If phoneme scoring is selected in the AC440 setup, mouse click on the corresponding number to indicate phoneme score. Clicking on the Up arrow and the Down arrow keys will score as correct and incorrect, respectively.
- b) **Store:** A mouse click on this button will store the speech threshold in the speech graph. A point can also be stored by pressing **S**.

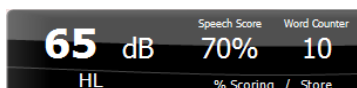

Frequency and Intensity display shows what is currently presented. On the left the dB value for channel 1 is shown and on the right side for channel 2. In the centre of the current *Speech Score* in % and the *Word Counter* monitors the number of words presented during the test.

Shuffled Wave file Testing

- 1) By clicking on the 'Shuffle' icon you can randomize the order of the wave files for speech test presentation

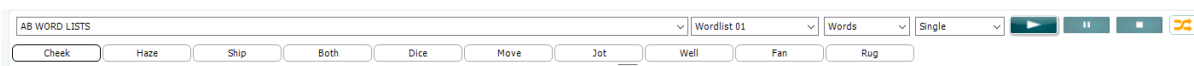

- 2) Re-clicking on the 'shuffle' icon will allow you to revert to the non-randomized material

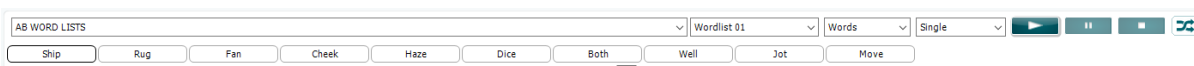



- 3) When looking through the material you can quickly see which list has been randomized by the highlighted Randomize button and if the feature is on then the list will be randomized when the list is selected.

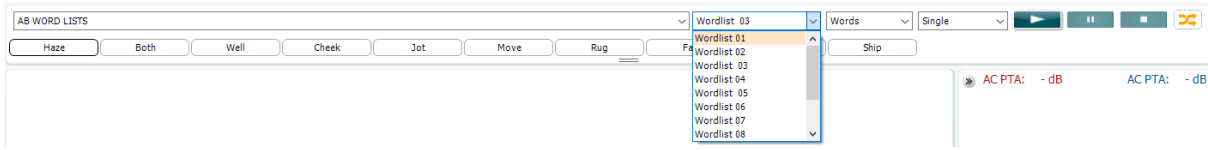

This feature gives much more flexibility and control when Speech testing. This feature is also implemented in other areas of the software where we are using speech wave files, for example in the SIN and SIQ tests.

There is a setting within the protocol configuration to enable this feature to be defaulted on



1.3.1 Speech audiometry in graph mode

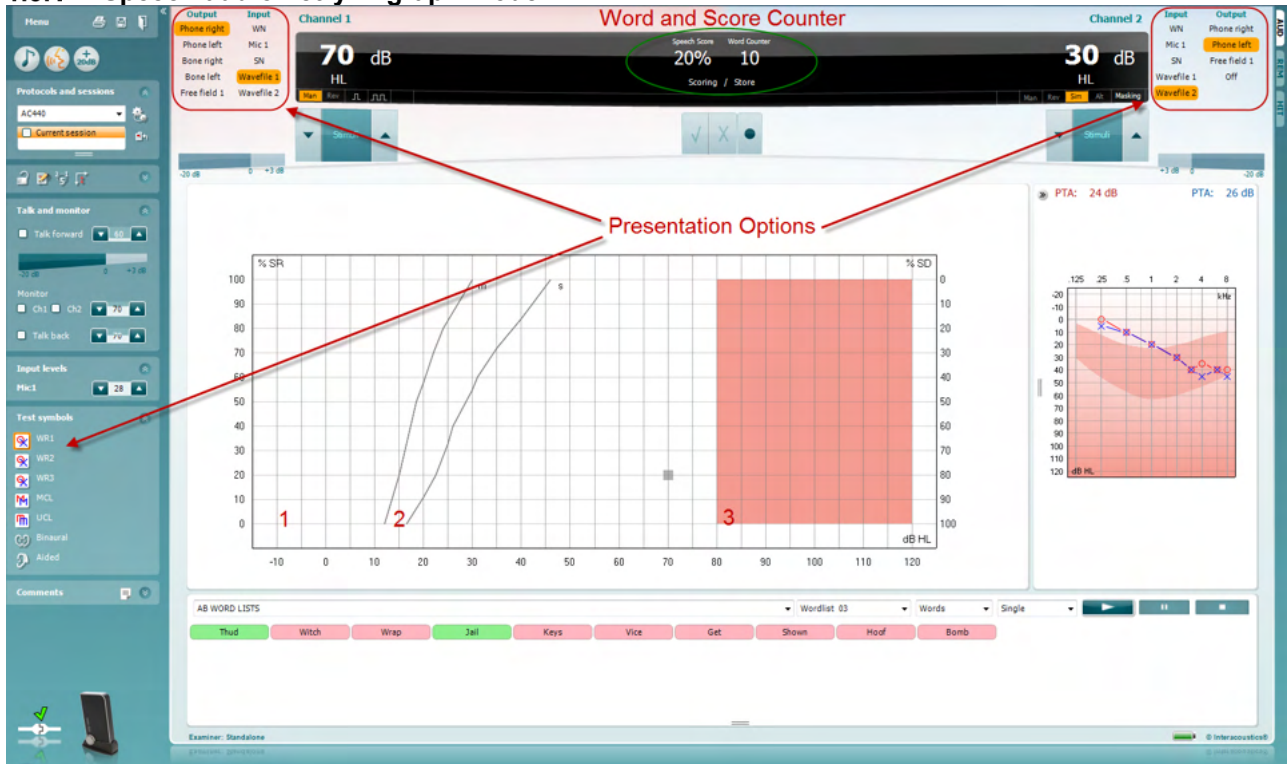

Graph mode presentation settings in the lower left corner and in the presentation options (Ch1 and Ch2) in the upper part of the screen you can adjust the test parameters during the test.

- 1) **The graph:** The curves of the recorded speech graph will be displayed on your screen. The x-axis shows the intensity of the speech signal, and the y-axis shows the percentage score. The score is also displayed in the black display in the upper part of the screen along with a word counter.
- 2) **The norm curves** illustrate norm values for **S** (Single syllabic) and **M** (Multi syllabic) speech material respectively. The curves can be edited according to the normative data you wish to use in the AC440 setup (see section 1.6.2.3)
- 3) **The shaded area** illustrates how high in intensity the system will allow. The *Extended Range +20 dB* button can be pressed to go higher. The maximal loudness is determined by the transducer calibration.



1.3.1.1 Dual speech graphs

The graphs can be shown as a dual audiogram to show left and right (see example below) this can be enabled in the Speech Setup Screen by clicking on the button called 'Dual Graph'.

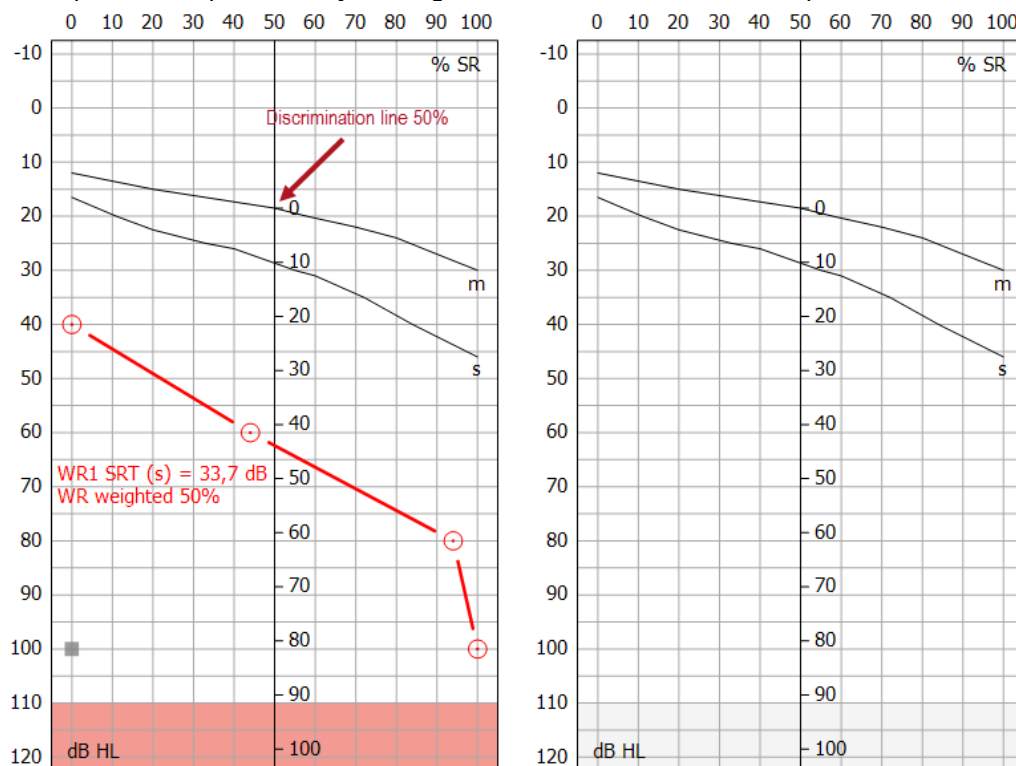



1.3.1.2 50% Discrimination line

The Graph View allows you to add a 50% discrimination line (see above dual audiogram image for example). This is enabled by checking on the 'Show 50% Discrimination Line' setting in the Speech Norm Curves setup (see image below).

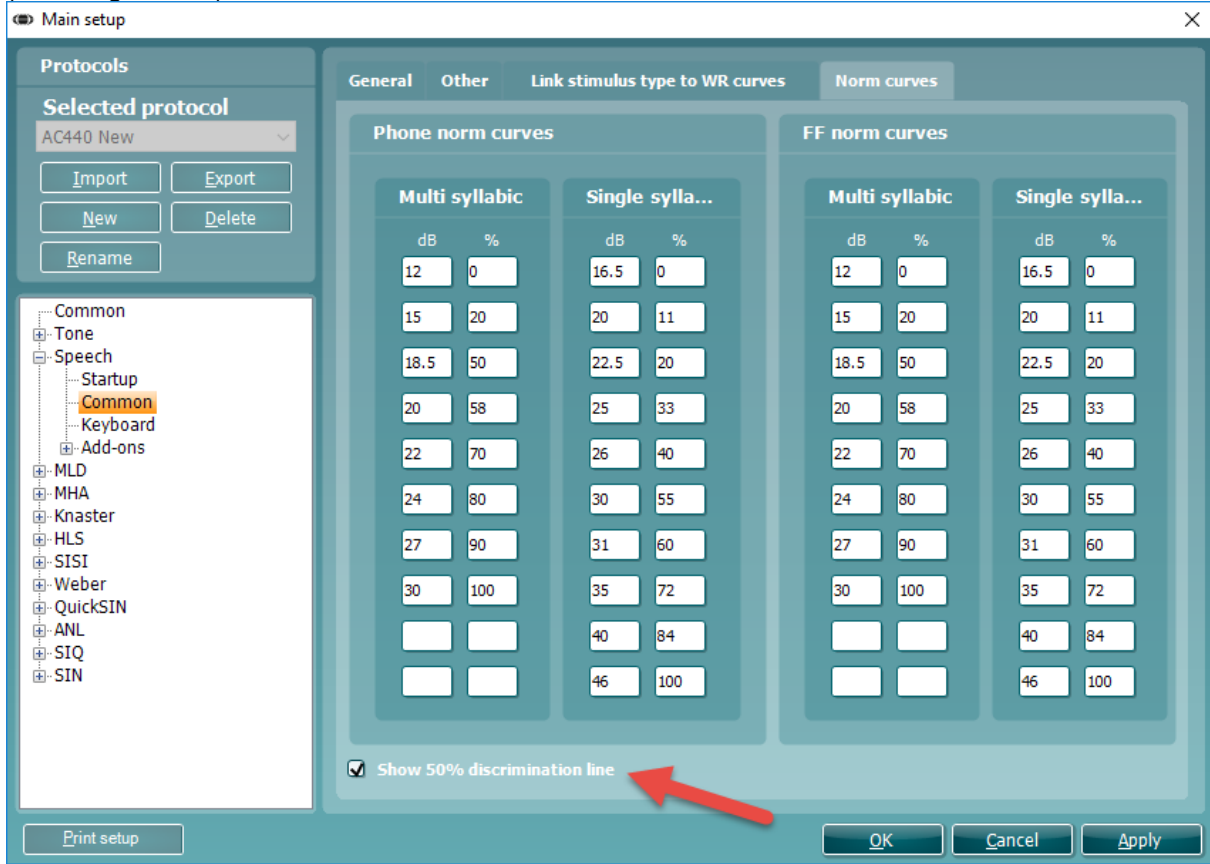

1.3.1.3 IEC dB hearing level scale

The ability to view the dB HL level scale against the speech audiogram is implemented within Free Field testing for markets using the IEC standard. This brings the ability to see all your measurements, regardless of transducer used, in the dB HL domain.

The setting for this needs to be amended under the 'General Setup', as highlighted in the image below.

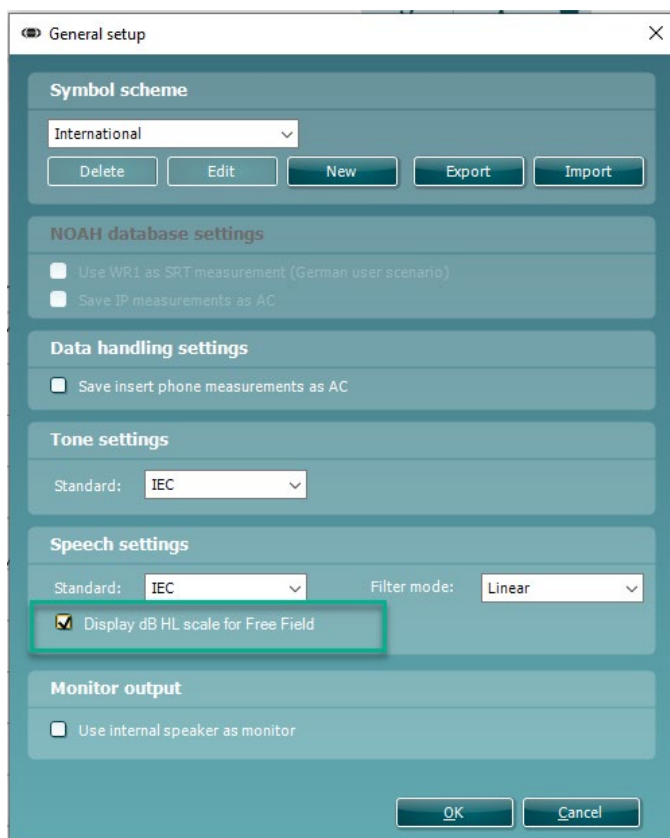

As a note, on changing this setting in General Setup, you will need to close your software for the setting to apply.

Once this setting has been enabled, your Speech graph will show an additional scale at the bottom of the graph indicating the dB HL value. See the example of this below.

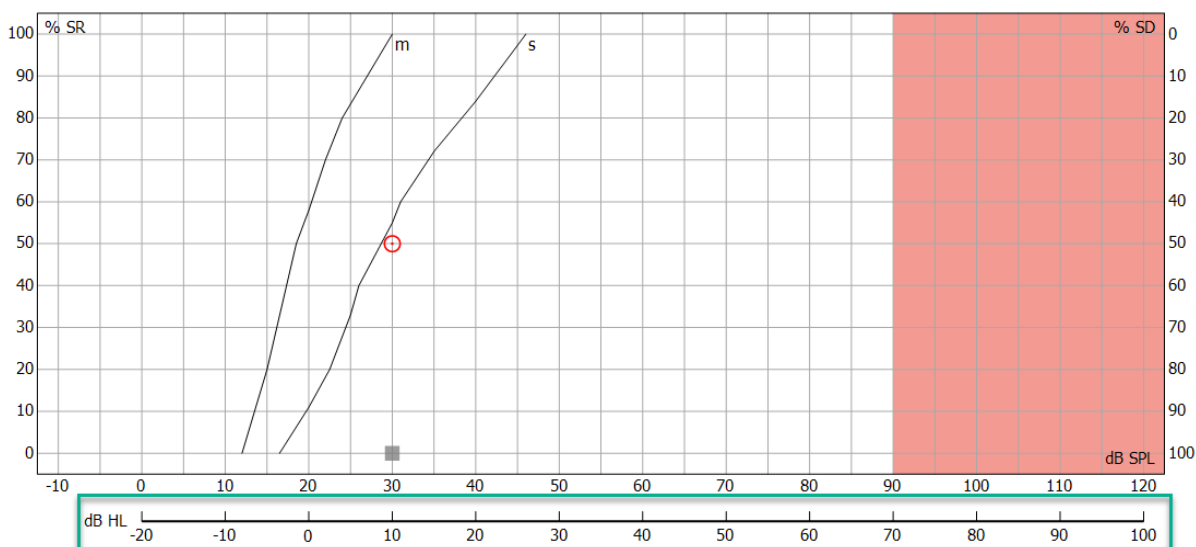



1.3.1.4 Bönninghaus & Röser calculation

The Bönninghaus & Röser calculation has been implemented for the German market.

This is a marker to recognise the accuracy of the test in relation to the patients' audiometry and to identify when the patient is suitable for compensation/insurance.

Settings in the speech setup need Bönninghaus and SRT enabled to show this score.

The score will appear as WR weighted (see example below).

WR1 SRT (s) = -12,6 dB X
WR weighted 20%

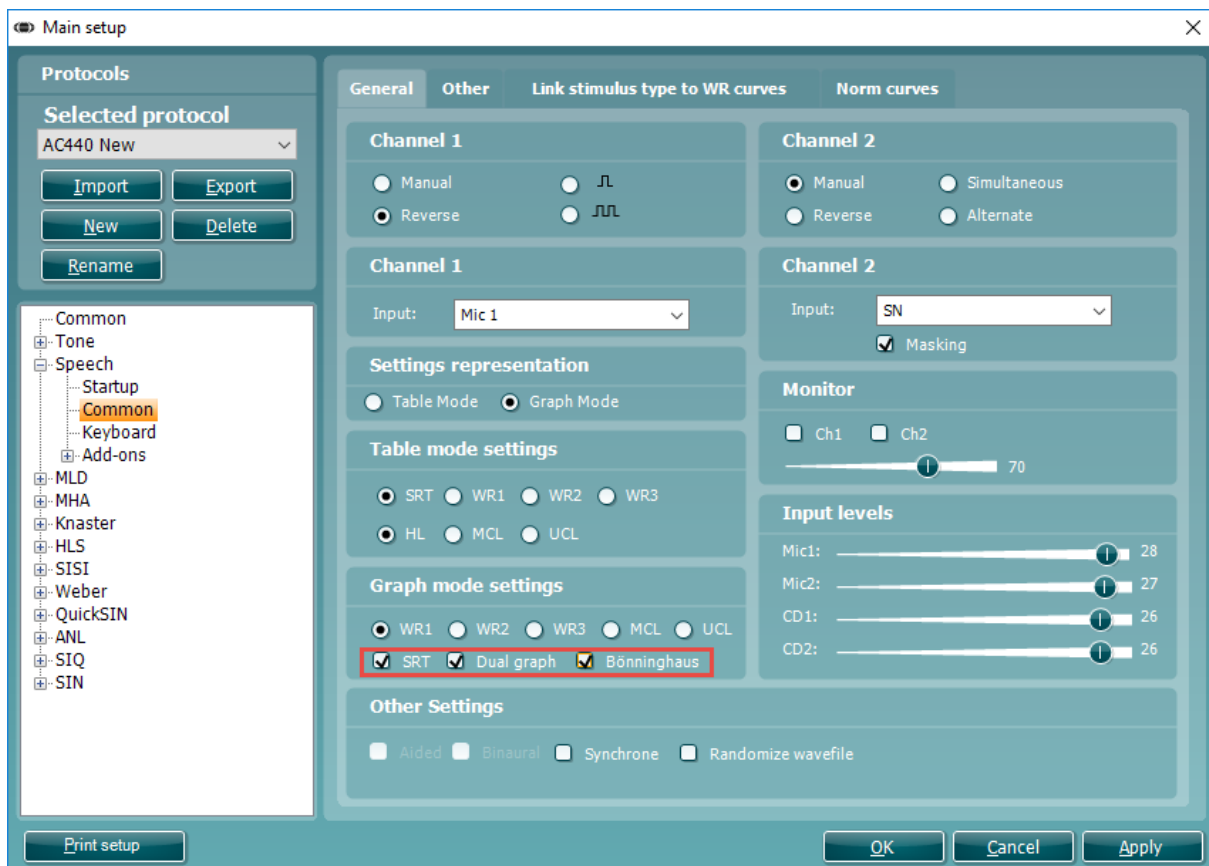

NOTE: The Bönninghaus & Röser Calculation is intended for use with the Freiburger Speech Test and the Freiburger Speech Norm Curves.



1.3.2 Speech audiometry in table mode

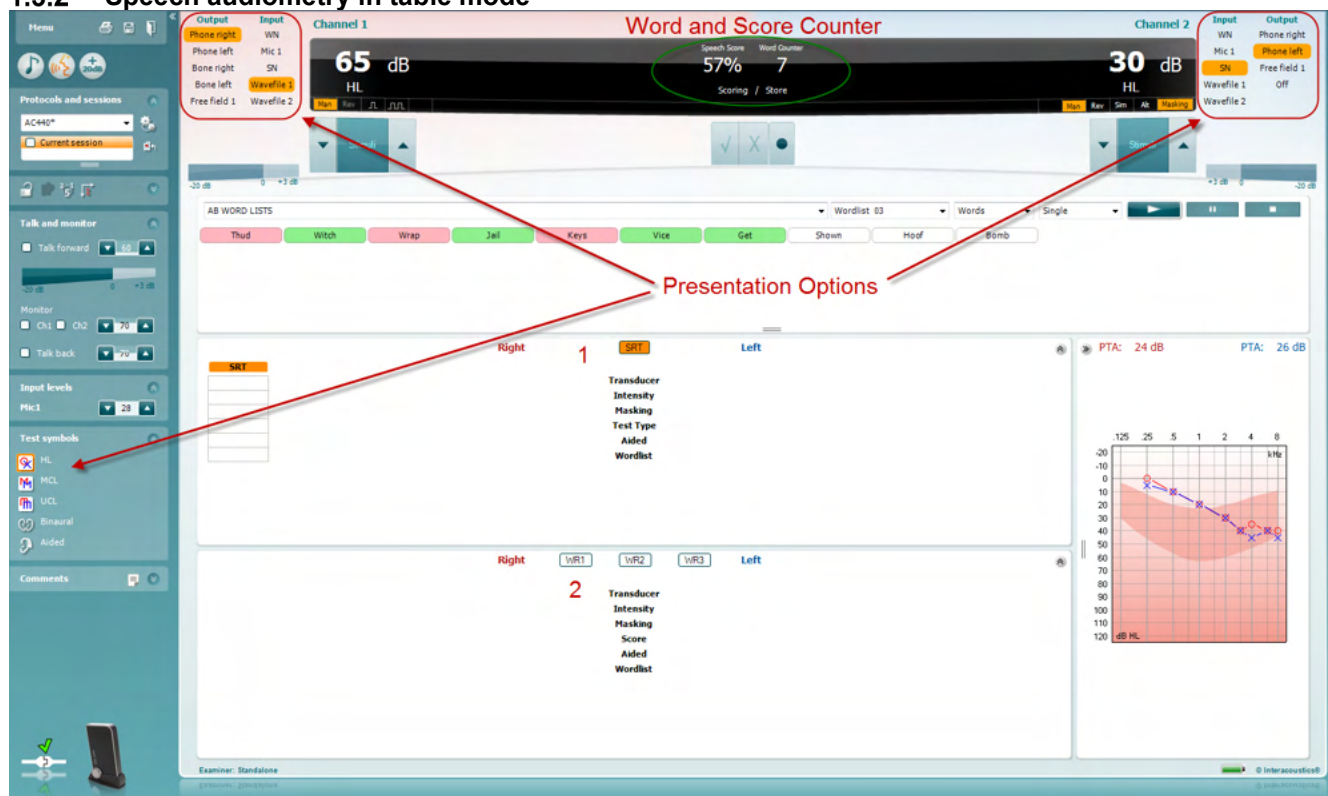

The AC440 Table Mode consists of two tables:

- 1) The **SRT** (Speech Reception Threshold) table. When the SRT test is active, it is indicated in orange **SRT**
- 2) The **WR** (Word Recognition) table. When WR1, WR2, or WR3 is active the corresponding label will be orange **WR1**

1.3.2.1 The SRT table

The SRT table (Speech Reception Threshold table) allows for measuring multiple SRTs using different test parameters, e.g., *Transducer*, *Test Type*, *Intensity*, *Masking*, and *Aided*.

Upon changing *Transducer*, *Masking*, and/or *Aided* and re-testing, an additional SRT entry will appear in the SRT table. This allows for multiple SRT measurements to be shown in the SRT table.

Please refer to section 1.5.5.1 for more information about SRT testing.

Right		SRT	Left	
SRT	SRT	Transducer Intensity Masking Test Type Aided Wordlist	SRT	SRT
Phone	Phone		Phone	Phone
30	10		10	30
15	15		15	15
HL	HL		HL	HL
	x		x	
Spondee A	Spondee B		Spondee A	Spondee B



1.3.2.2 The WR table

The word recognition (WR) table allows for measuring multiple WR scores using different parameters (e.g., *Transducer, Test Type, Intensity, Masking, Binaural and Aided*).

Upon changing Transducer, Masking, Binaural and/or Aided re-testing an additional WR entry will appear in the WR table. This allows for multiple WR measurements to be shown in the WR table.



Please refer to section 1.5.5.2 for more information about Word Recognition testing.

Right		WR1	WR2	WR3	Left
WR1	WR1			WR1	WR2
Phone	FF1	Transducer		Phone	FF2
55	55	Intensity		55	30
		Masking			
85	95	Score		90	100
	x	Aided			
NU-6 LIST 1A	NU-6 LIST 3A	Wordlist		NU-6 LIST 1A	Spondee A



1.4 Binaural speech

It is only possible to test Speech binaurally in the Speech audiometry screen. This can be done if channel 1 and channel 2 are using the same air conduction transducer and only when a different output is chosen. E.g., right ear in channel 1 and left ear in channel 2 or vice versa.

When the binaural mode is activated  in graph mode the stored symbol will be shown as a “B” see below: 

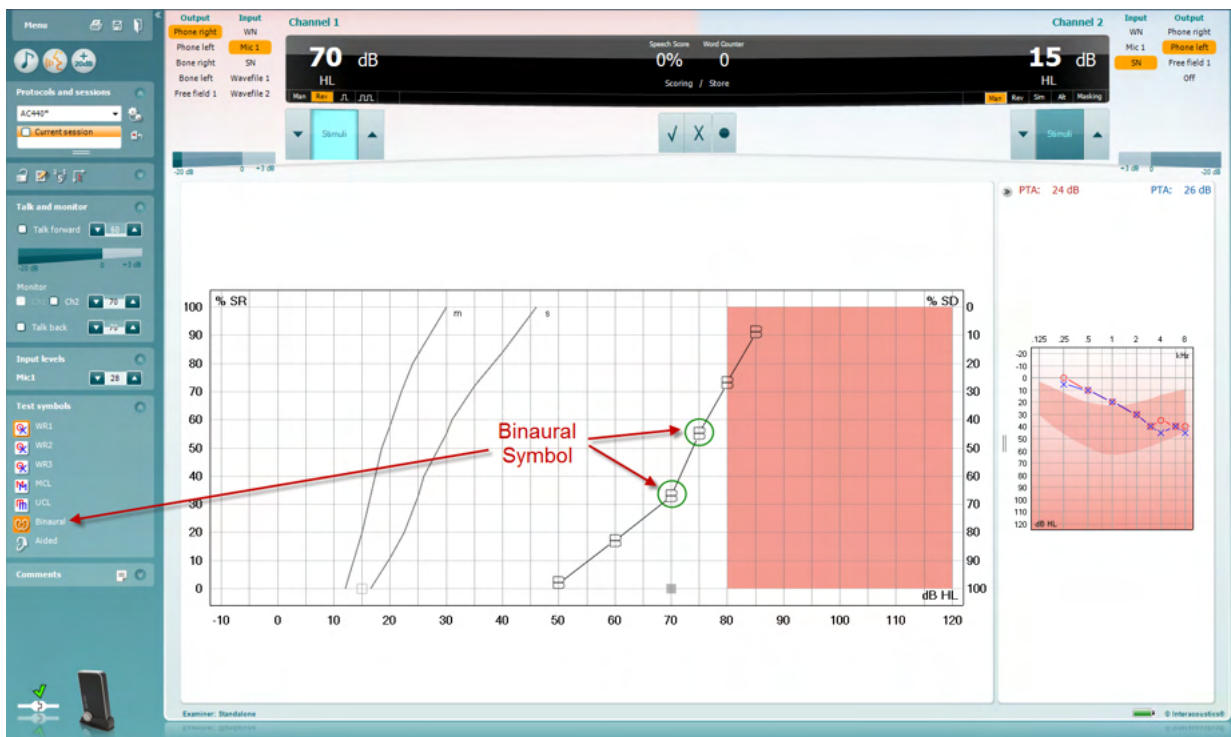

When the binaural mode is activated  in table both results will be stored even if the level is different. This means when this is stored it will store the channel 2 level and display the results as well as channel 1. See below:

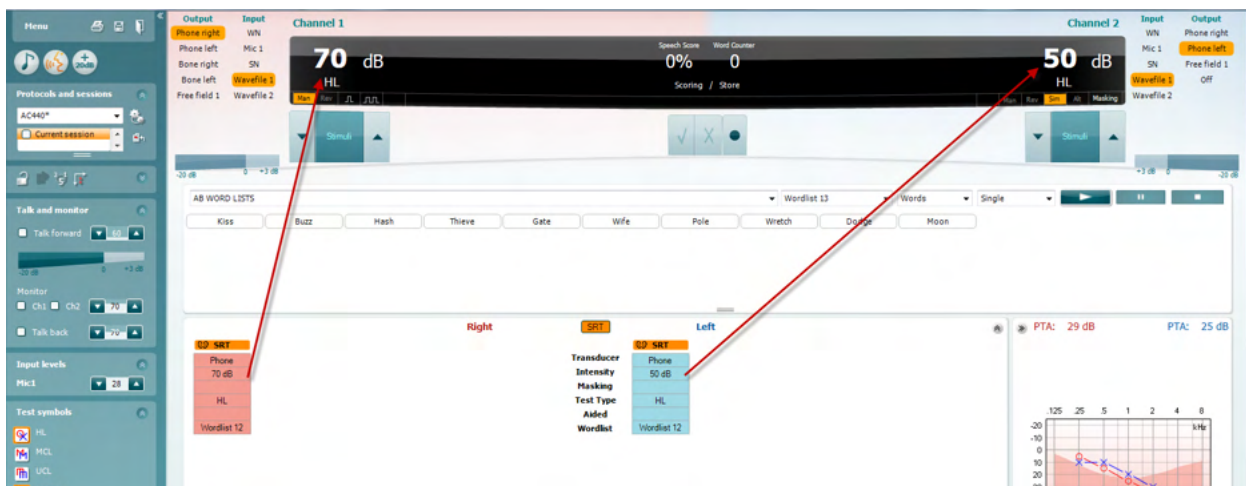

In 'Binaural mode' the Pure Tone Average (PTA) calculations will be calculated monaurally only, although the value will be displayed above each Audiogram.



1.5 Counselling tab

Under the menu icon there is a tab titled counselling. This is where the counselling features of the software are contained.

1.5.1 SoundStudio

The SoundStudio is a counselling tool which allows you to recreate sound environments to simulate real-life situations for use during hearing aid fitting and counselling.

To find this please go to the Menu icon in the top left corner and select Counselling.

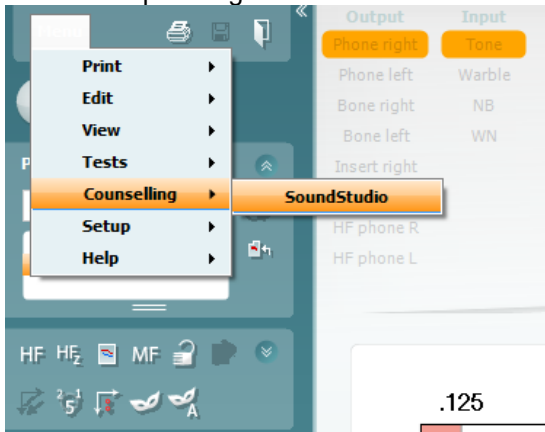

For more information regarding the SoundStudio, please



1.6 Clinical application of the AC440 tests

This section will give a short introduction to the clinical applications of the AC440 module. The methods described here primarily based on the textbooks by Stach (1998) and Katz (2002) and describes one way of performing the individual tests. Other standards may, however, dictate other procedures.

Air conduction audiometry

In air conduction audiometry, a test signal is presented to the test subject via headphones or insert phones. The test subject responds to the signal by pressing a patient response button. The audiometric threshold is defined as the lowest intensity at which the patient can detect the test signal 50% of the time. The purpose of air-conduction audiometry is to establish the hearing sensitivity at various frequencies. The test provides information about the conductive and sensory systems of hearing but cannot distinguish between conductive and sensorineural hearing losses.

Required items:

- The Callisto™ hardware
- Licensed AC440 Audiometry module within your Callisto™ hardware
- Headphones or insert phones
- A response button



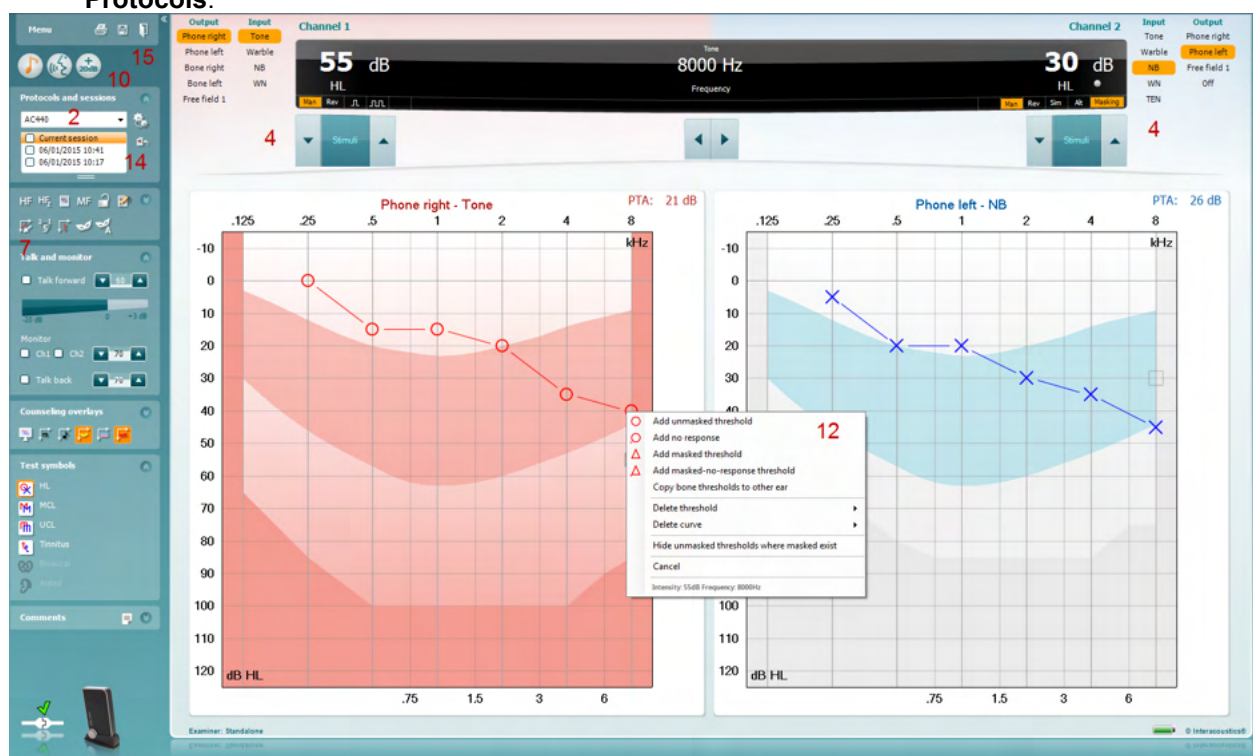

Test procedure:

- 1) Open the Callisto™ Suite through your patient management system, Noah or OtoAccess®.
- 2) Ensure you are in the AUD module of the Suite and if needed select a test protocol in the **List of Protocols**.



- 3) Perform otoscopy to make sure that any anatomical abnormalities are considered, and that cerumen is not obstructing the ear canal. Perform a medical history to find out whether there are any confounding factors which may prevent you from performing the test or make considerations for. It is also good to ask if the patient is experiencing tinnitus. If yes, you may consider doing the test using warble tones or narrow band noise instead of pure tones which can be hard to distinguish from the tinnitus at some frequencies.



- 4) Select the input and output for **channel 1**.
If masking is needed, use the **channel 2** to determine masking level and frequency. Note that this decision is usually made after performing an unmasked audiogram based on differences in thresholds. Channel 2 should be muted or switched off in the beginning of the evaluation. If preferred, Auto Masking or Masking Help can be turned on. These features are intended to help the inexperienced clinician when masking is required. Please see section 1.7.2.2 and Appendix 4 for more information on this.
- 5) Explain to the patient that they will hear several different tones through the headphones and that they should press on the response button whenever the tone is audible, even if it is very faint.
- 6) Place the headphones over the patient's ears and begin the audiometry test. If one ear is assumed to have worse hearing compared to the other, start the audiometry on the better ear. If the hearing level is assumed to be equal on both ears, start on the right.
- 7) Use the arrow buttons on the PC keyboard or the audiometer keyboard to set the frequency and intensity. You may also choose **Mouse controlled audiometry**  to do the audiometry using only the mouse. Left click to stimulate and right click to store the threshold.
- 8) Begin the testing at 1000 Hz at an intensity which you think the patient should hear. A normal start level would be approximately 40 dB for a person assumed to have normal hearing and 30 dB above presumed threshold if hearing loss is present. However, the start intensity should never exceed 70-80 dB.
- 9) Present the stimulus for approximately 2 seconds and wait for the patient to respond. The Stimuli area will light up while presenting, visually indicating that the stimulus is presented. The stimuli can be presented three ways:
 - a. Pressing on the space bar
 - b. Hovering the mouse over the Stimuli button
 - c. Using the stimuli button on the Audiometry keyboard (additional accessory)
- 10) If no reaction is obtained, increase the intensity by 10dB steps until the patient responds. If the patient has a severe hearing loss you may want to press the **Extended Range +20 dB** button , which allows activation above a 55 dBHL intensity of compatible transducers.
- 11) You may now begin the threshold search using the Hughson Westlake procedure, known as the "10 down, 5 up" method: Present the stimuli. If the patient hears it, decrease by 10 dB. If the patient does not hear it, increase by 5 dB. The threshold is set at the intensity where the patient can perceive the tone 50% of the time during the ascending portion of the threshold search (when increasing by 5 dB). Typically, the tone should be heard 2 out of 3 times to be considered the threshold. .
- 12) In case of mistakes during the test you can right click on the threshold which will prompt a menu with edit options: **Add unmasked threshold, Add no response, Add masked threshold, Add masked-no response threshold, Copy bone thresholds to other ear, Delete threshold, Delete curve, and Hide unmasked thresholds where masked exist.**
- 13) If the difference between the two ears exceeds 40 dB (55 dB if using insert phones) there will be a risk of cross hearing (e.g., the good ear is responding to the tone presented to the worse ear). In this case you may consider retesting the worse ear while masking the better ear. Masking can be activated using the Ch2 input and output dropdown lists in the upper part of the screen.
- 14) If you have other audiograms on the patient saved in Noah or OtoAccess® you can compare the new audiogram to a previous one using the session list. This is done by using the checkboxes of the historic sessions that you like to overlay.
- 15) To save the audiogram press **Save**  or **Save and Exit** .



1.6.1 High frequency audiometry⁴

High frequency audiometry (above 8 kHz) is performed using the same procedure as normal air conduction audiometry. Note, however, that you are only allowed to test within the range of the headset calibration. That is, if the headset is only calibrated for a range of 125 Hz – 8 kHz you will not be allowed to present tones at higher frequencies.

High frequency audiometry is helpful when testing hearing impairments caused by ototoxicity, noise exposure and acoustic traumas as these mainly affect the high frequencies. This frequency area is more susceptible to the effects of external factors such as medications and loud noises than the low and middle frequencies.



Required items:

- The Callisto™ hardware
- Licensed AC440 Audiometry module within your Callisto™ hardware with High Frequency functionality
- A calibrated high frequency audiometric headset (HDA300)
- A response button

Test procedure:

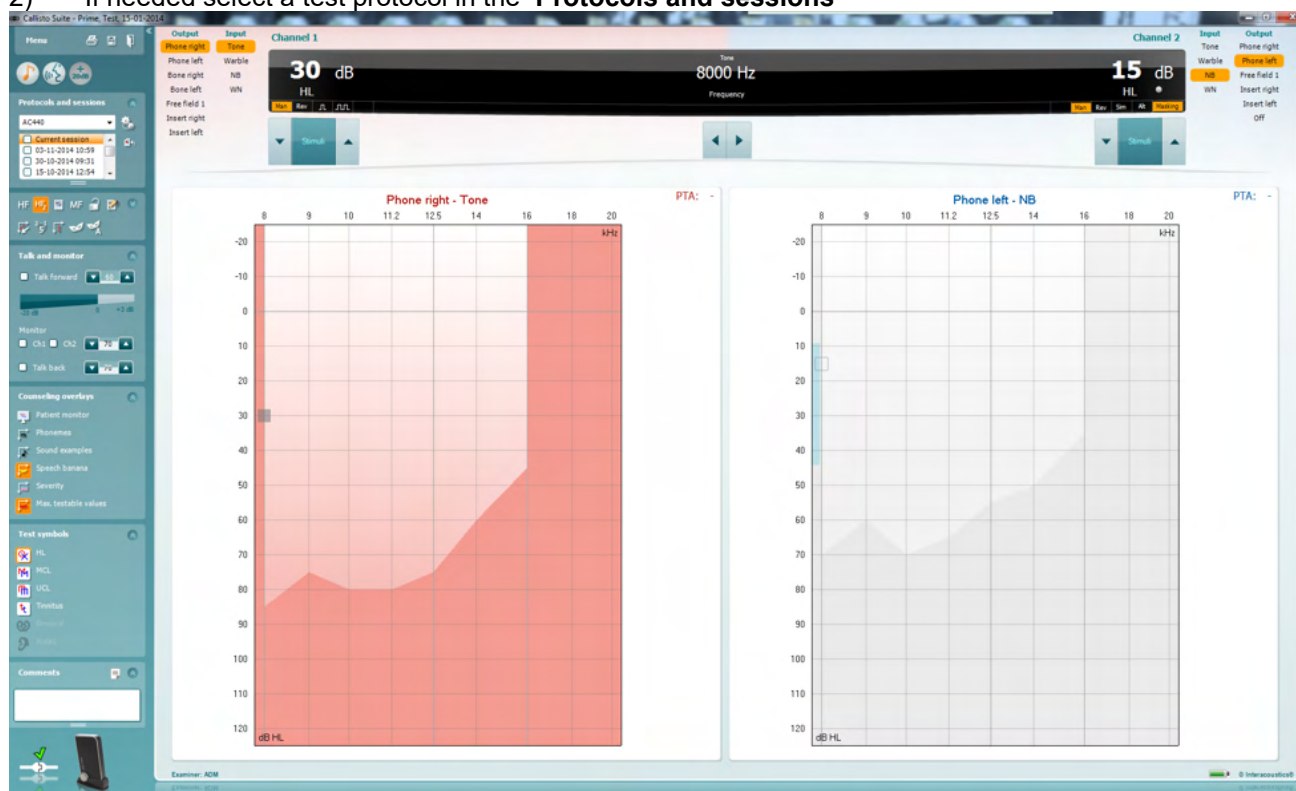
- 1) Open the AC440 module through your patient management system, Noah or OtoAccess®.
- 2) If needed select a test protocol in the **Protocols and sessions**



- 3) To perform a high frequency audiometry, press the **HF** button  or **HFz** button  in the front screen.
- 4) Conduct high frequency audiometry using the normal air conduction audiometry method (see section 1.6 above for details), ensuring that you are using proper headsets. The HDA 300 can be calibrated for 125 Hz to 16 kHz.



1.6.2 Multi frequency audiometry⁴

Multi frequency audiometry lets the clinician test more frequencies than the traditional audiometric test frequencies. This may be useful when dealing with steeply sloping hearing impairments as it becomes possible to obtain a more precise measure of the slope of the hearing loss. It is also helpful in the evaluation of tinnitus as it provides the option to match the tinnitus.

Required items:

- The Callisto™ hardware
- Licensed AC440 Audiometry module within your Callisto™ hardware with Multi Frequency functionality
- Headphones or Insert phones
- A patient response button

Note: If doing Multi Frequency testing in the high frequencies (8-16 kHz) a high frequency headset must be used.

Test procedure:

- 1) Open the Callisto™ Suite through your patient management system, Noah or OtoAccess®.
- 2) Select the AUD Tab and If needed select a protocol from the **List of Protocols**.
- 3) To perform a multi frequency audiometry, click the **MF** button  in the front screen. You may want to check that the multi frequency settings are in accordance with your preference in the AC440 setup (see section 1.6.2.2).
- 4) Conduct high frequency audiometry using the normal air conduction audiometry method (see section 1.6 above for details). The cursor will jump in small frequency steps during the test providing you with multiple thresholds and a detailed curve.

Note: Evaluation of tinnitus can be used for both the purpose of identifying the nature of the sound the patient is experiencing and the purpose of masking the sound. Instruct the patient that you will now try to reproduce the exact sound that they are experiencing as precisely as possible. Start by finding the frequency and subsequently finding the amplitude using 5 dB steps. This way the patient only needs to concentrate on one thing at the time. After replicating the tinnitus, present a noise (NB) to the ear where the sound is experienced. Increase the noise in 5 dB steps until the patient claims that the tinnitus is masked (Nielsen & Carver 1997).

1.6.3 Bone conduction audiometry

In bone conduction audiometry, the test signal is presented by a bone vibrator placed on the mastoid. The bone vibrator uses the skull to transfer the vibrations to the cochlear and bypasses the outer and middle ears. Bone conduction thresholds thereby provide a measure of the cochlear and retro cochlear function regardless of the outer and middle ear function; therefore it allows you to distinguish between conductive, sensorineural, and mixed hearing thresholds detected through Air conduction Audiometry. The difference which is detected between the bone and air conduction is called the air-bone gap. It is recommended to start a hearing assessment first with air-conduction measurements, followed by bone conduction measurements.

Required items:

- The Callisto™ hardware
- Licensed AC440 Audiometry module within your Callisto™ hardware
- A calibrated bone conductor (B71)
- A patient response button

Test procedure:

- 1) Open the AC440 module through Noah or OtoAccess®.
- 2) If needed select a test protocol in the **List of Protocols**.
- 3) Prior to bone conduction audiometry, perform the *Air conduction audiometry*, as described in section 0.

⁴ Multi frequency audiometry requires an additional license for the AC440. If not purchased, the button is greyed out.



- 4) Place the bone conductor on the mastoid of the worst ear and choose *Bone Right* or *Bone Left* from the **channel 1** output dropdown list and select the desired test signal (typically Tone). In the **channel 2** input and output dropdown lists you can decide whether masking is to be employed. If so, you will need to place the headset on the patient as well.

Conduct high frequency audiometry using the normal air conduction audiometry method (see section 0 above for details).

Note: Without appropriate masking applied where necessary you cannot know which cochlea is responding, as there is always no interaural attenuation in bone conduction audiometry. We will always assume that it is the better ear that is responding. In the case of asymmetrical hearing losses, bone conduction masking should always be considered.

1.6.4 Masking

In cases where a symmetrical hearing loss is detected, traditional audiometry without masking is usually sufficient. However, be aware that in cases of asymmetrical hearing loss, one cannot be certain that the test ear is the one detecting the sound. For example, when measuring an audiogram on a patient with hearing within the normal range on one ear but a moderate to severe hearing loss on the other, there is a potential risk that the better ear is the one responding, even if it is not the ear being tested. That is because the sound vibration may travel through the head and be heard by the opposite ear when the vibrations of the signal are of sufficient magnitude. Therefore, you are measuring the thresholds from the wrong ear.

To prevent this phenomenon in causing an erroneous measurement, masking noise can be used to occupy the better ear (non-test ear) while testing the other one (Stach 1998, Katz 2002 and British Society of Audiology 2004). Masking can be applied to air conduction, bone conduction and speech audiometry. The need to mask the better hearing ear is linked to the interaural attenuation which equals the amount of attenuation the sound is exposed to on its way through the skull. Even though the interaural attenuation is very individual and varies with frequency it can, on average be estimated to a minimum of 40 dB for supra-aural headphones and 55 dB for inserts. Regarding bone conduction, the interaural attenuation is a minimum of 0 dB which means that crossing over of the stimulus may occur all the time.

Required items:

- The Callisto™ hardware
- Licensed AC440 Audiometry module within your Callisto™ hardware
- Calibrated Headphones or insert phones
- A calibrated bone conductor (B71)
- A patient response button

Test procedure:

- 1) Open the AC440 module through Noah or OtoAccess®.
- 2) Select a test protocol in the list of **Protocols and sessions** if needed.
- 3) Perform the *Air conduction audiometry* as described in section 1.6.
- 4) Perform *Bone conduction audiometry* as described in section 1.5.3
- 5) If the difference between the air conduction threshold of the worse ear and the bone conduction threshold of the better ear exceeds 10 dB, masking is needed.

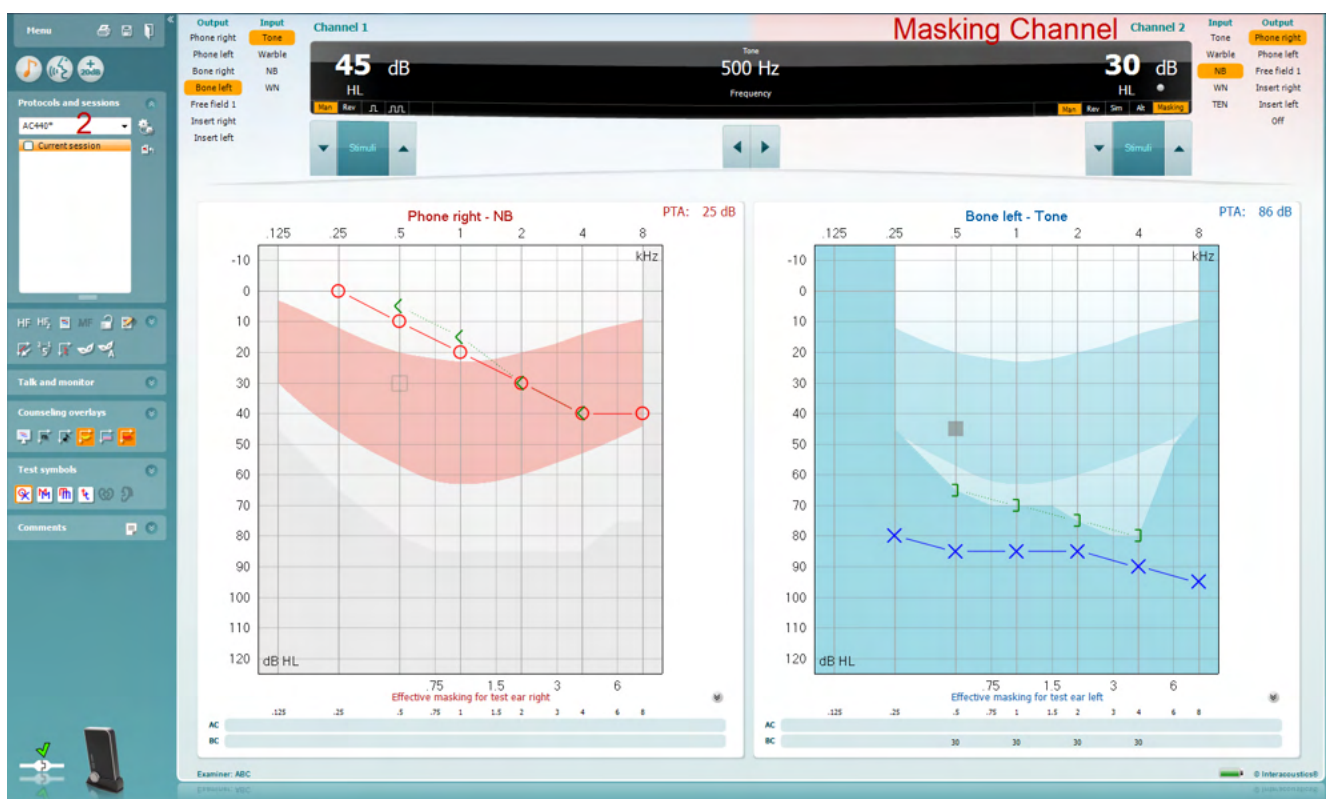

There are many ways of applying clinical masking. The method you use is your decision. Regardless of the masking method **channel 2** is used to occupy the better ear. In the example above channel 2 should be set to *Right* (non-test ear) using the preferred masking stimulus preferred (usually Narrowband *NB*). Ensure that *Rev* is ticked making the masking noise continuous. **Channel 1** should be set to *Left* (test ear) using the preferred stimulus (usually *Tone*). You can set the masking and tone level using the buttons on the screen, the PC keyboard, or the dedicated keyboard. While trying to establish the true threshold of the left ear the right ear is now distracted with noise.

When storing a threshold while the masking is enabled, the used masking level is stored in the masking table under the ear that is being tested. The terms 'Effective masking' in this situation refers to the narrow band noise level that was loud enough to effectively mask a pure tone of the indicated level heard by the unmasked ear.

1.6.5 Speech audiometry

Most people acquire hearing aids because they or their relatives report that they have trouble hearing speech. Speech audiometry has the advantage of utilising speech signals and is used to quantify the patient's ability to understand everyday communication. It examines the patient's processing ability in relation to their degree and type of hearing loss which can vary greatly between patients with the same hearing loss configuration.

Speech audiometry can be performed using several tests. For example, SRT (Speech Reception Threshold) refers to the level at which the patient can repeat 50% of the presented words correctly. It serves as a confirmation of the pure tone audiogram, gives an index of hearing sensitivity for speech, and helps determine the starting point for other supra-threshold measures such as WR (Word Recognition). WR is sometimes also referred to as SDS (Speech Discrimination Scores) and represents the number of words correctly repeated, then expressed as a percentage.

Note that there is a predictable relationship between the patient's pure tone threshold and speech reception threshold. Speech audiometry may therefore be useful as a cross-check of the pure tone audiogram.



Required items:

- The Callisto™ hardware
- Licensed AC440 Audiometry module within your Callisto™ hardware
- Headphones, insert phones, or free field speakers
- A microphone or wave files

Test procedure:

Before performing the speech audiometry, you may wish to complete tone audiometry. This provides valuable predictive information useful in the speech testing. Furthermore, the PTA level (Pure Tone Average) gives you a basis for calculating the starting point for speech testing.

- 1) Open the AC440 module in the Callisto™ Suite through your patient management software, Noah or OtoAccess®

- 2) Go to speech testing by pressing the **Speech Screen** button



- 3) If needed, select a test protocol in the **List of Protocols**.

Select the input and output stimuli and intensity levels for **channel 1**.

If masking is needed, configure **channel 2** also.

- 4) Explain to the patient that he/she will now hear some words/numbers/sentences through the ear phones/free field speakers. Instruct him/her to repeat what is said even though it may be very faint. Patients may also be encouraged to guess if they are unsure about the word/number/sentence. If performing the speech test in noise do not forget to instruct the patient not to focus on the noise but on the speech.

- 5) Start presenting the words, numbers, or sentences. Depending on the setup for speech testing (see section 1.6.2.3) the test can be scored using the following buttons:



Correct, Incorrect, and Store

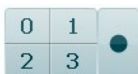

Number of correct Phonemes and Store

The speech score will be displayed in the black bar:

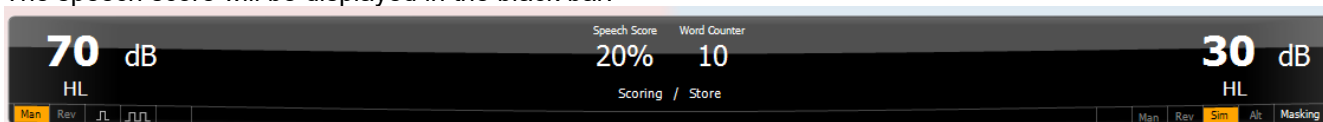

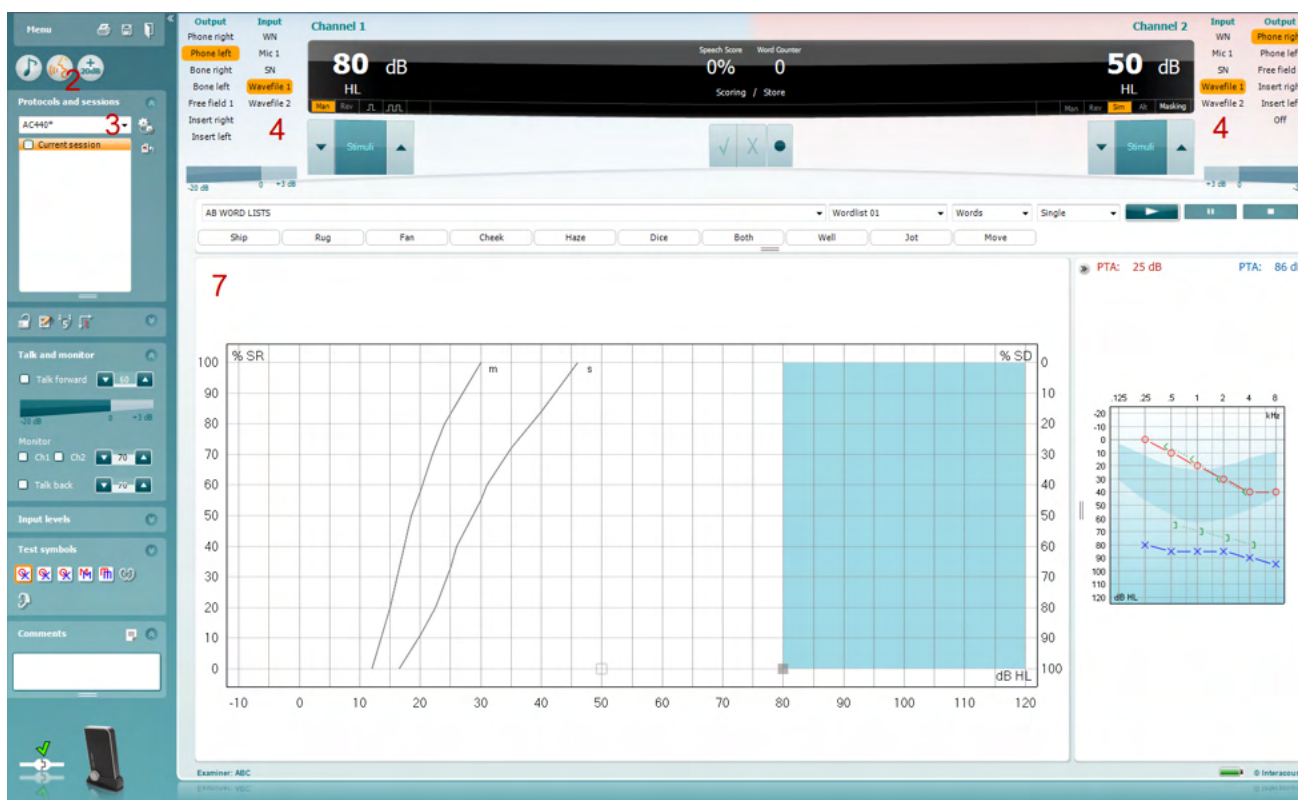

Note: The AC440 Setup allows for selecting whether the speech test is to be performed in Graph or Table Mode (see section 1.6.2.3). This screen shot shows graph mode.

In case of mistakes during the test you can right click on the threshold which will prompt a menu with edit options. Besides deleting single thresholds or whole curves it also provides the option to **Add no response**, **Add masked threshold** and **Add masked-no response threshold**.

Note: If performing speech audiometry in free field and calibration is done at one location, please be aware that free field calibration values are likely to be incorrect at other locations because of acoustical circumstances. The differences can easily differ up to 10 dB.



1.6.5.1 Speech reception threshold (SRT) in table mode

The SRT examines at which level 50% of the speech material (usually numbers or spondaic words) is repeated correctly. The SRT can be used as a cross check of the air conduction audiometry and should closely agree with the PTA (Pure Tone Average). The PTA can be calculated in different ways but is usually the average of thresholds obtained at 500, 1000, 2000 and 4000 Hz. It is generally accepted that if the PTA and the SRT is within ± 6 dB of each other the accordance is good, if it is ± 7 to 12 dB it is adequate, and if it ± 13 or more it is poor.

- 1) Perform *air and bone conduction audiometry* as described in section 0 and 1.5.3 to obtain the PTA.
- 2) Open the **Speech Screen** 
- 3) Ensure that the **SRT** test is active. This is shown by the SRT label being orange **SRT** MCL and UCL speech testing can be conducted by selecting **MCL** or **UCL**
- 4) Choose the input for **channel 1** (microphone or wave file). In case of wave files, check if the preferred material, and wordlist are selected.

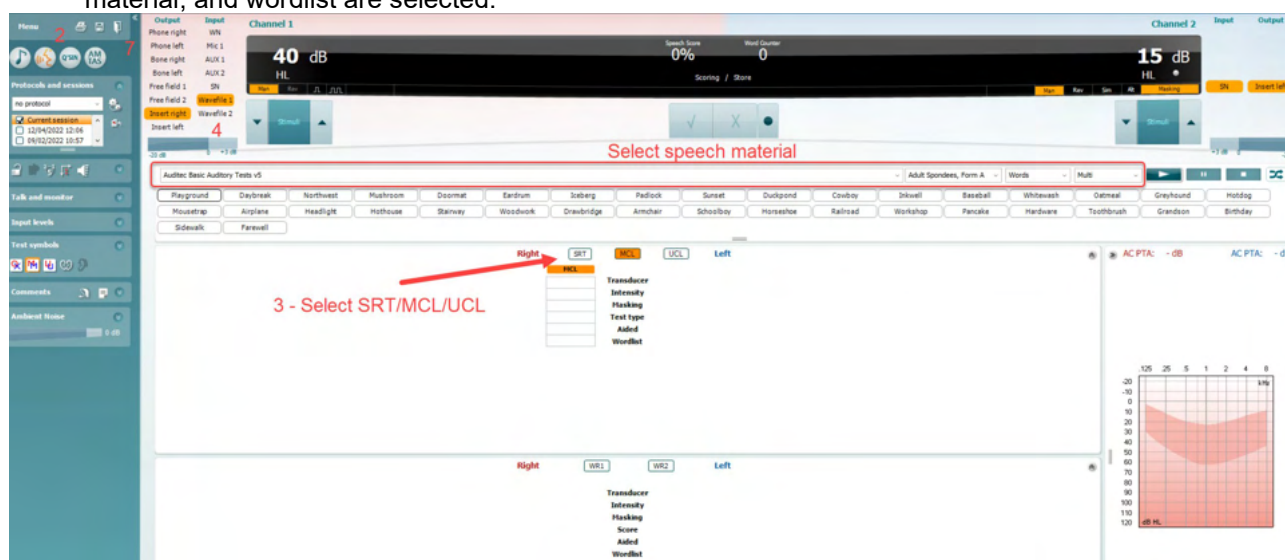

Note: In case of **microphone** the speech material can be calibrated by speaking into the microphone. Adjust the corresponding arrow keys to 0 VU (see details in section 1.5.5).

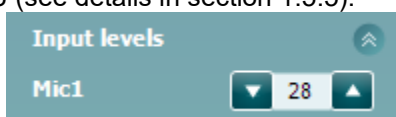

- 5) Start with the better hearing ear according to the audiogram and set the intensity to 15 dB above Pure Tone Average.
- 6) Begin presenting the speech material and reducing the intensity in 5 dB steps for every correctly repeated word. Use the **Store** button to store the SRT.
- 7) Upon changing *Transducer*, *Masking*, and/or *Aided* and re-testing an additional SRT entry will appear in the SRT table (see illustration above). This allows for multiple SRT measurements to be shown in the SRT table.

If the SRT is not in accordance with the air conduction thresholds, the air conduction audiogram should be checked, and the procedure repeated (Nielsen & Carver 1997; Katz 2002).



1.6.5.2 Word recognition (WR) in table mode

The Word Recognition score determines the patient's discrimination ability expressed in a percentage. It provides information about what phonemes the patient has difficulty hearing at a particular intensity level. This is helpful for counselling and rehabilitation purposes. The diagnostic value has shown to be low, but it is generally accepted that the word and sentence recognition are least affected by conductive and most affected by neural loss.

There are numerous ways of performing the WR. The procedure described below is a suggestion.

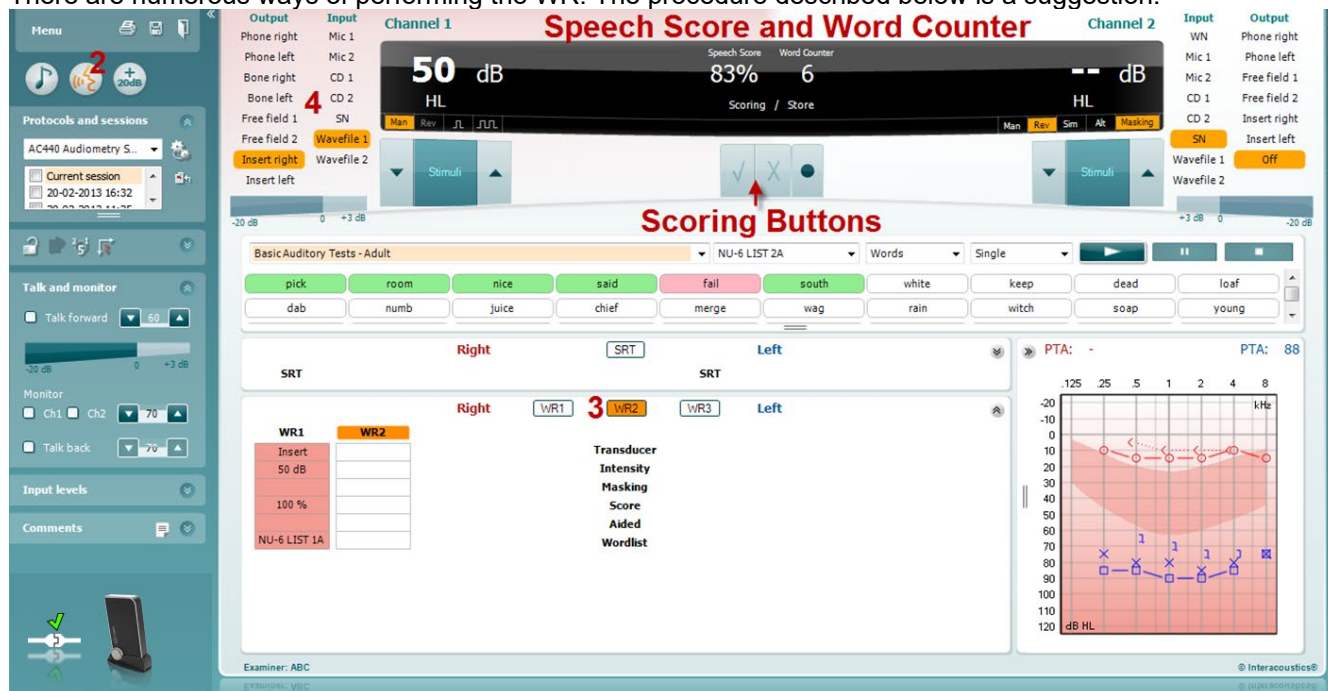

1) Perform *air and bone conduction audiometry* as described in section 0 and 1.5.3 to obtain the PTA.

2) Open the **Speech Screen**



3) Ensure that WR test is active.

In table mode, this is shown by the corresponding WR label being orange **WR1**

4) Choose the input for **channel 1** (Microphone or wave file). In case of wave files, select the preferred material and wordlist (see below). Note that calibration is the same for SRT (see section 1.6.5.1 above).

5) Start in the better hearing ear according to the audiogram and set the intensity to approximately 30 or 40 dB above PTA (minimum 55 dB). In cases where recruitment is present start lower at about 20 dB above PTA and ask the patient if the level is comfortable after 2-3 words.

6) Begin presenting the speech material. Use the scoring buttons to score and store the results. The current score (in percent) will appear in the black bar.

7) Upon changing *Transducer*, *Masking*, and/or *Aided* re-testing an additional WR entry will appear in the WR table. This allows for multiple WR measurements to be shown in the WR table

8) If you have other speech audiograms on the patient saved in Noah or OtoAccess® you can compare the new audiogram to a previous one using the session list. This is done by using the checkboxes of the historic sessions that you like to overlay.

To save the audiogram press **Save**  or **Save and Exit** .



1.6.5.3 Speech testing with a microphone

- 1) Connect the microphone to the *TF* input on the on the hardware.



Microphone Input

- 2) Open the AC440 software, go to the Speech screen 

- 3) Choose *Mic1* in the input **channel 1** list.

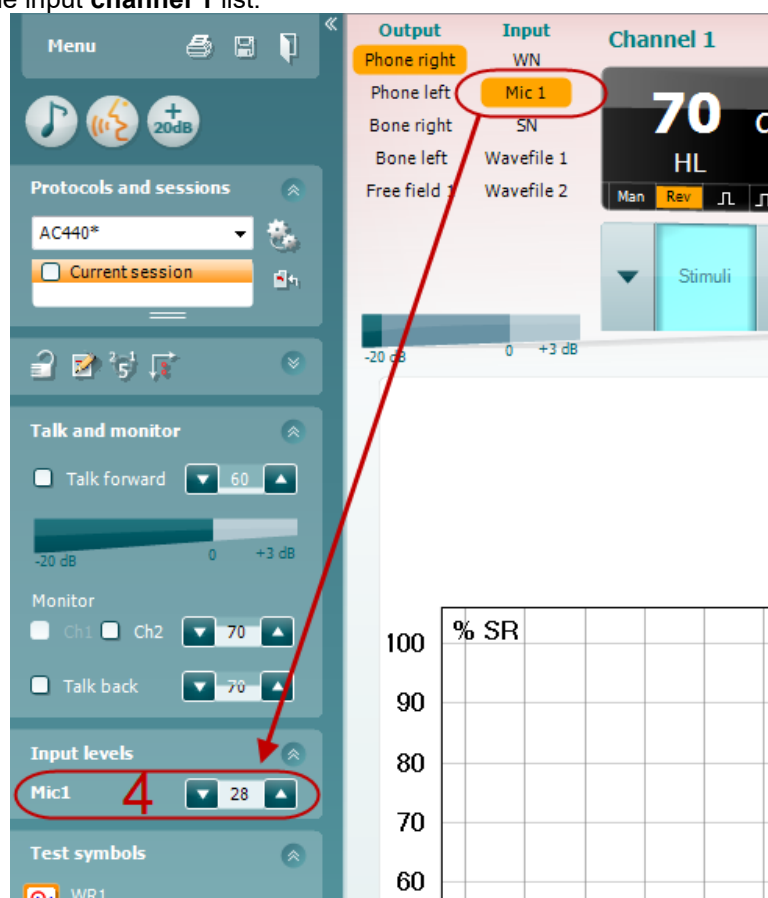

- 4) Adjust the input levels for the *Mic1* until you reach an average of approximately 0 dB VU on the VU meter while speaking into the microphone at a normal conversation level. When the VU meter is adjusted the microphone input is ready for use. Perform the speech audiometry as described in section 1.6.5.5.



1.6.5.4 Speech testing with wave files⁵

The AC440 also allows for testing with wave files if installed on the PC. The default speech material can be selected in the AC440 setup (see section 1.6.2.3).

1) To use wave files choose them in the **channel 1** list.

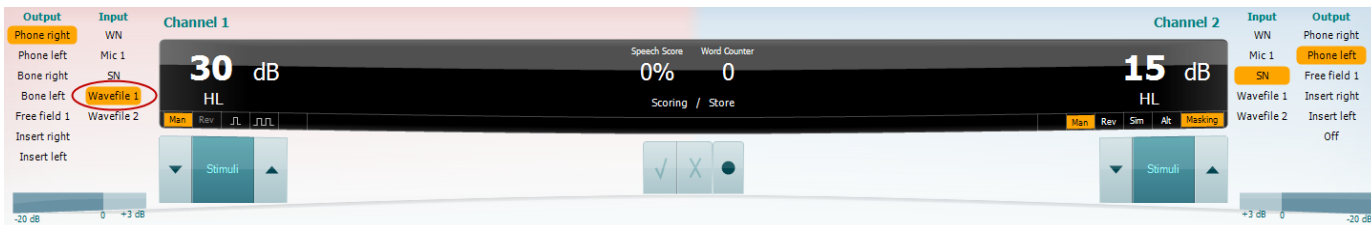

2) The speech material can be selected from the four dropdown lists.

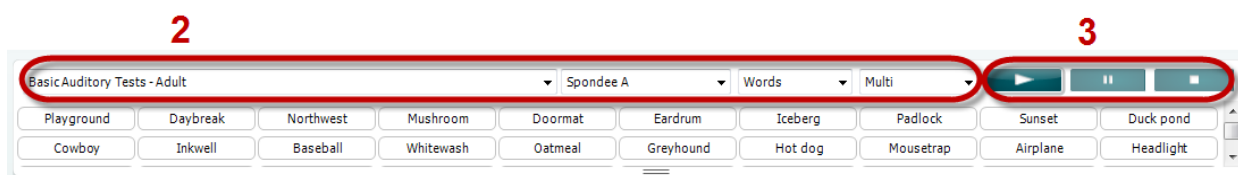

3) **Play, Stop, or Pause** the speech test on the three buttons on the right side.

Note: Appendix 1 explains how to import own wave files.

4) By clicking the button indicated in the image below, you can randomise the order in which your materials are presented. **Note:** this setting will be reflected when the play button is pushed as the word order will then shuffle.

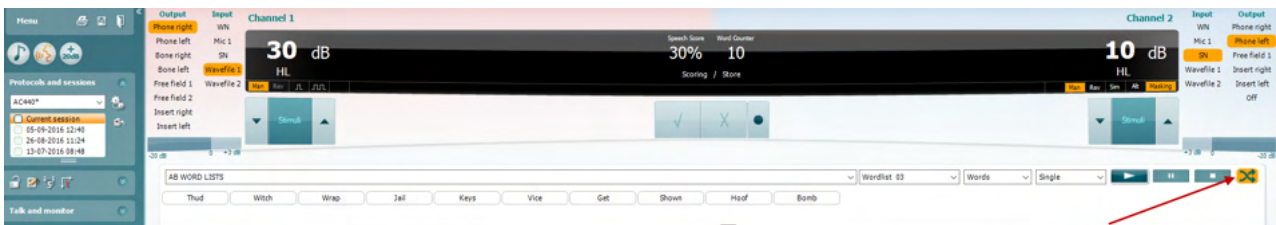

Should you wish to edit your speech score after it has been assigned you can right click on the word, and it will allow you to re-score it as shown below.

This feature can be used during testing or after the test has completed.

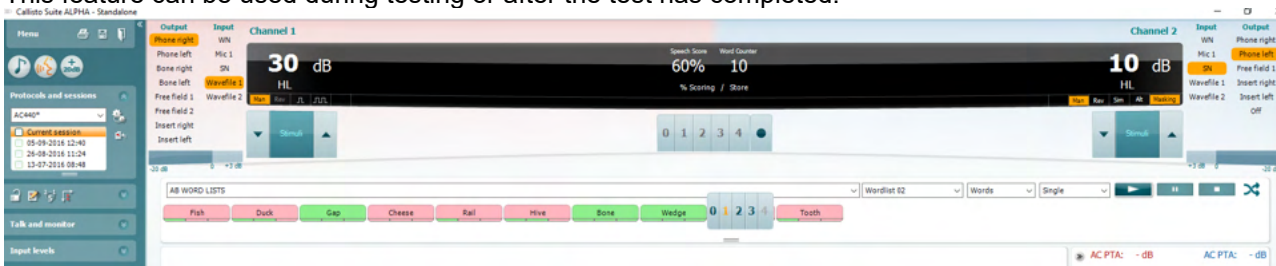

5) Should you wish to choose where to begin your speech testing then you can click on the designated wavefile ahead of starting the test. Clicking on it will highlight it with a bolder outline. The material will then play from here on clicking the 'play' icon.

⁵ Speech audiometry with wave files requires an additional software license.

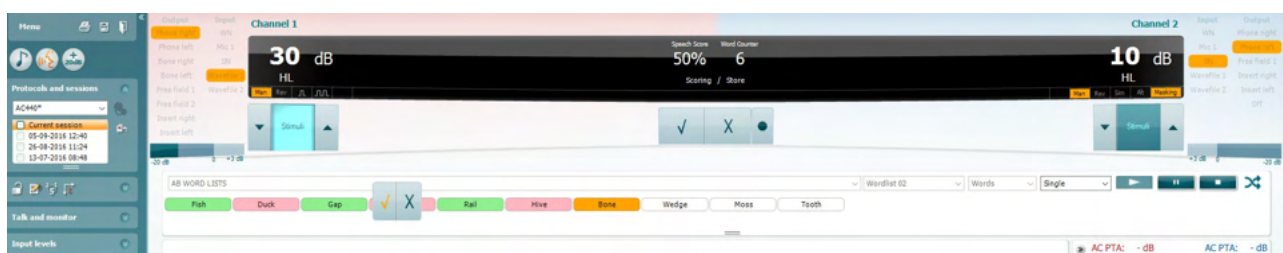

1.6.6 Master hearing aid (MHA)⁶

MHA is a hearing aid fitting procedure consisting of three hearing aid simulated high pass filters of -6 dB, -12 dB, -18 dB per octave and a HFE filter (High Frequency Emphasis) equivalent to -24 dB per octave through the audiometric headphones. This gives a rough sense of the benefits of a hearing aid and what could eventually be gained by getting properly fitted hearing aids. The filters can be activated individually on both channels enabling the audiometer to serve as a 2-channel master hearing aid.

Required items:

- The Callisto™ hardware
- Licensed AC440 Audiometry module within your Callisto™ hardware with MHA functionality
- Headphones or insert phones
- A microphone or wave files

Test procedure:

When having performed the hearing assessment you may want to start discussing a possible hearing aid solution. However, there is no guarantee that the patient is positive towards such a solution. He/she might not even have acknowledged their hearing impairment and may therefore not be motivated or prepared for this prospect. In this situation MHA may be useful.

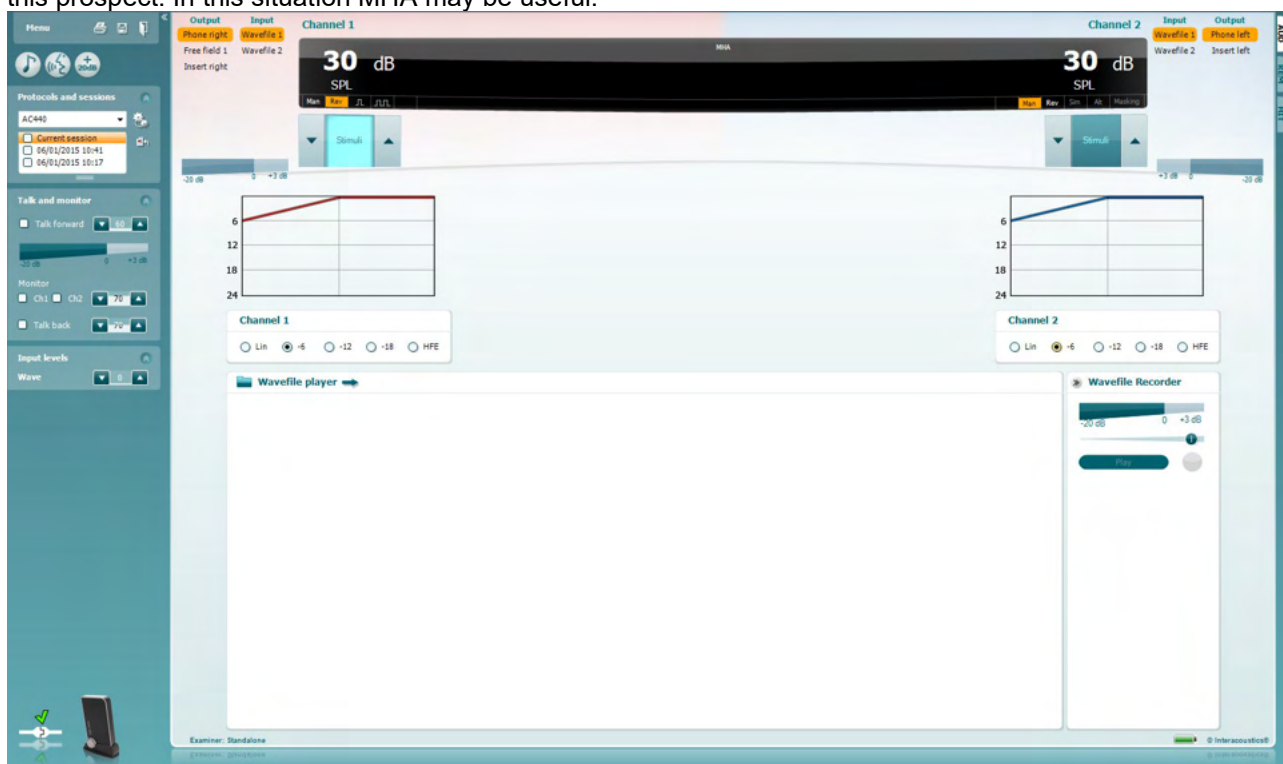

⁶ MHA requires an additional software license



- 1) Open the AC440 and enter the MHA screen by selecting **Menu | Tests | MHA**.
- 2) Select headphones or inserts in the **channel 1** output list.
- 3) Select *Mic 1* or *Wavefile* in the **channel 1** input list.
If using wave files, you can *Browse* and play them in the bottom of the screen. You also have the option to record a wavefile using the Microphone if you choose Wavefile input.
- 4) In this example the simulation starts in the *-12 dB* filter. It may, however, be advisable to start in *Lin* (no filtering) as listening to the input signal with one's own hearing for a moment is likely to have a strong effect when having to compare with the filtered input. The procedure is, however, up to you and the defaults can be setup in the AC440 setup (see section 1.6.2.4).

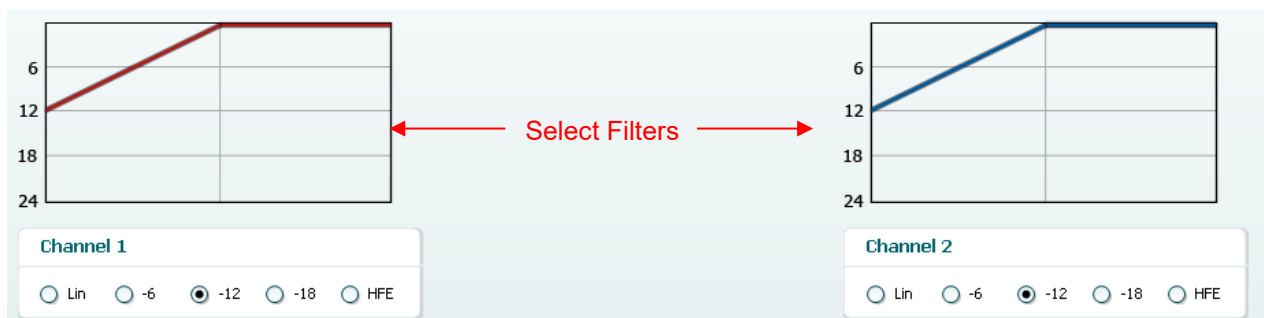

- 5) Before mounting the headsets on the patient describe to them that this tool can give an impression of what a hearing aid might sound like. Perhaps let him or her listen to the signal with their natural hearing as it is (without manipulating the sound). Explain that they are now listening to the wave file or live voice with their own natural hearing. In a minute, though, the sound will be changed trying to give them an impression of what it could sound like if they acquired hearing aids. Note that it may, be necessary to point out that a hearing aid will sound even better than what they are about to hear which is an approximation. A hearing aid will be fitted more accurately based on the individual hearing loss. The MHA is meant to give them an idea as to how the amplification can provide them much more audibility and thereby improve their quality of life significantly.
- 6) The selected MHA filter can be visualized in the graph. Toggle between the filters and see the effect.
- 7) During the simulation it is possible to adjust the volume of the signal using the **dB HL Decrease/Increase channel 1/channel 2** buttons.

1.6.7 Hearing loss simulation (HLS)⁷

The HLS offers a simulation of the hearing loss through the audiometric headphones or the high frequency headset and is primarily aimed at the family members of the hearing impaired. It is a valuable tool as a hearing loss in many families may result in frustrations and misunderstandings. Knowing what the hearing loss sounds like gives an impression of what the hearing impaired goes through every day.

Required items:

- The Callisto™ hardware
- Licensed AC440 Audiometry module within your Callisto™ hardware with HLS functionality
- Headphones or a free field speaker
- A microphone or wave files

Test procedure:

- 1) Open the AC440. To perform the HLS counselling, an audiogram is needed. You should therefore start by performing *Air Conduction Audiometry* (as described in section 1.6) or retrieving an old audiogram in the **List of historical sessions**.

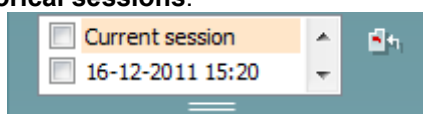

⁷ HLS requires an additional software license.



- 2) When an audiogram is present, enter the HLS screen by selecting **Menu | Tests | HLS**.
- 3) Select headphones or inserts in the **channel 1** output dropdown list.
- 4) Select *Microphone* or *Wave files* in the **channel 1** input dropdown list.
If using wave files, you can *Browse* and play them in the bottom of the screen. You also have the option to record a wavefile using the Microphone if you choose Wavefile input.
- 5) Before mounting the headset on the friend or relative explain the audiogram. Use examples of what the hearing impaired may not be able to hear anymore such as some speech sounds and other sounds that are likely to occur in everyday surroundings.
- 6) It may be advisable to start the simulation session by letting the relative listen to the input signal with his or her natural hearing for a moment. This is likely to have a strong effect when having to compare with the simulation. The procedure is, however, up to you and the defaults can be setup in the AC440 setup (see section 1.6.2.5).

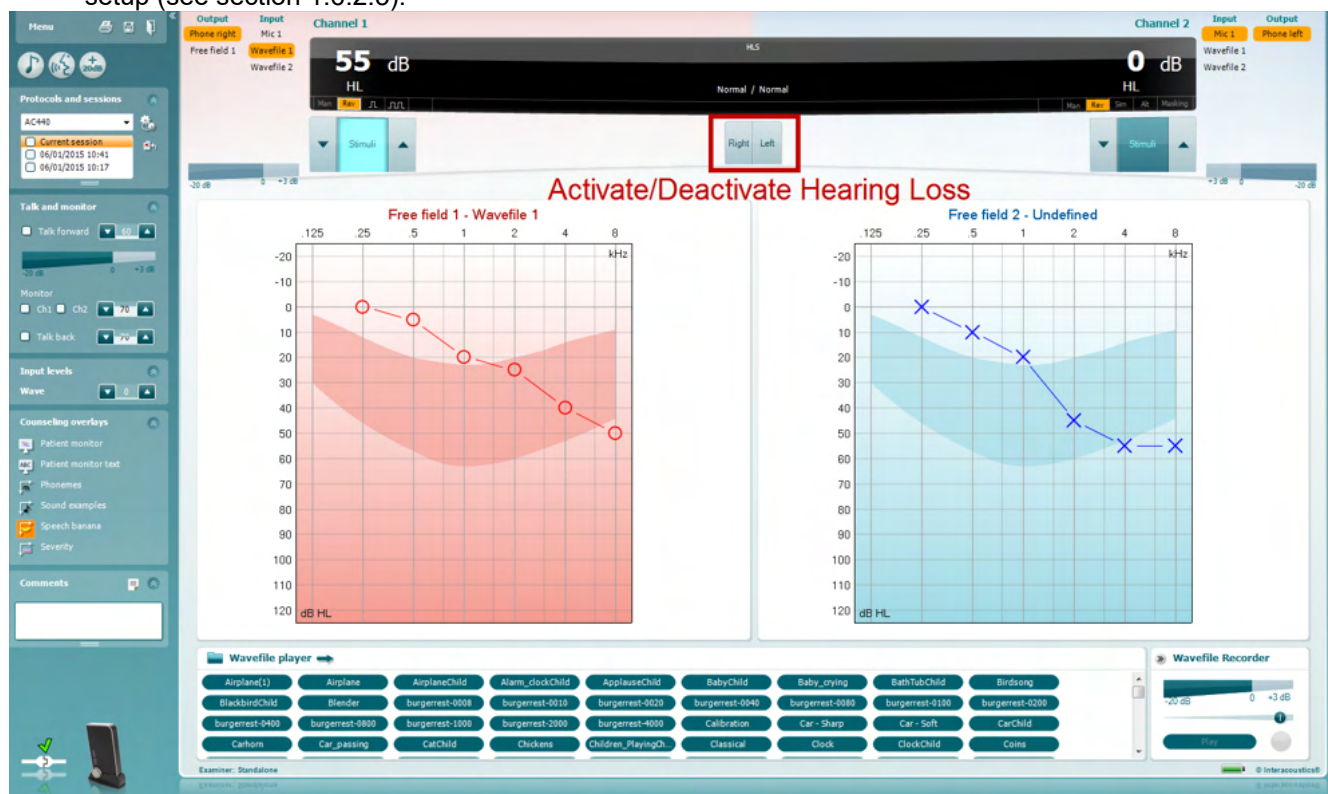

Start simulating by clicking the **Right** and/or **Left** buttons corresponding to the ear to be simulated. The text above each button will then change from *Normal* to *ON*.

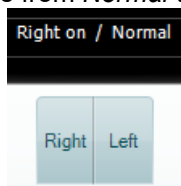

During the simulation it is possible to adjust the volume of the signal using the **dB HL Decrease/Increase channel 1/channel 2** buttons.

Patient monitor text with HLS

Now clinicians can input text in the patient monitor, which can then be read by out loud while simulating the hearing loss. This is to help with counselling and adding text which can be read out loud can make it easier than asking someone to spontaneously say something. Please see section 1.6.2.5 for more information on how to setup the Patient Monitor.



1.6.8 Short increment sensitivity index⁸

SISI is designed to test the ability to recognise 1 dB increase in intensity during a series of bursts of pure tones presented 20 dB above the pure tone threshold for the test frequency. It can be used to differentiate between cochlear and retro cochlear disorders as a patient with a cochlear disorder will be able to perceive the increments of 1 dB, as where a patient with a retro cochlear disorder will not.

Required items:

- The Callisto™ hardware
- Licensed AC440 Audiometry module within your Callisto™ hardware with SISI functionality
- Calibrated Headphones or insert phones
- A patient response button

Test procedure:

- 1) Open the AC440 and enter the SISI screen by selecting **Menu | Tests | SISI**.
- 2) Select Tone or Warble Tone in the **channel 1** input list. If needed masking can be selected in the **channel 2** input dropdown list.
- 3) Select headphones or inserts in the **channel 1/channel 2** output lists
- 4) Set the input level to 20 dB above threshold using the **dB HL Decrease/Increase channel 1/channel 2** buttons or **arrow keys** on the PC keyboard.

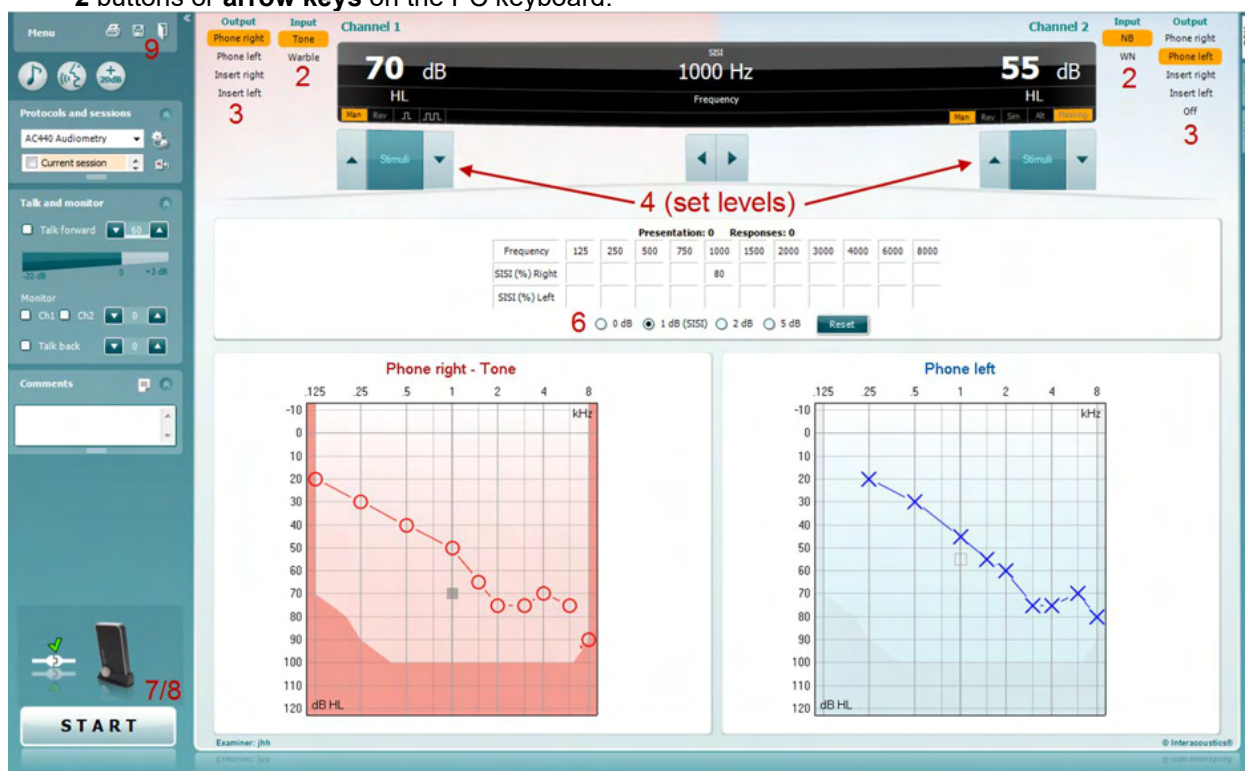

- 5) Explain to the patient that they will now hear a series of tones. If suddenly one tone seems louder than the other ones the response button should immediately be pushed.
- 6) Select the preferred type of SISI test. Setting the system to 1 dB increments is the classical SISI. If the patient can hear these increments and scores high, cochlea damage is likely. You may also choose 0 dB, 2 dB, or 5 dB increments. If the patient does not manage to get a high score on the SISI test this could be indicative of retro-cochlear damage.
- 7) Start the test by pressing **START**. During the testing the frequency and intensity can be adjusted manually (see illustration). The system will automatically count the number of reactions from the patient. Note that the system needs 20 presentations to calculate a SISI score.

⁸ SISI requires an additional software license.



- 8) Press **STOP** to end the test.
- 9) Save the SISI test by clicking **Save** 

1.6.9 Weber

Originally the Weber test distinguished between conductive and sensorineural hearing loss through use of a tuning fork. The fork was softly struck and placed in the middle of the patient's forehead. If the patient heard the tone better in the poorer ear the hearing loss was conductive, and if the tone was heard better in the better ear the hearing loss was sensorineural at the given frequency. Today the Weber is most often performed using a bone conductor because the tuning fork method only allows testing at one frequency unless you have multiple tuning forks. The bone conduction oscillator is placed in the midline and as a stimulus is mostly a signal of 250, 500, and 1000 Hz chosen which should be clearly audible to the patient. Using an audiometer together with a bone conductor to do the Weber is more reliable and flexible than the tuning fork method and has therefore become widespread.

Required items:

- The Callisto™ hardware
- The AC440 software
- A bone conductor (B71)

Test procedure:

- 1) Open the AC440 and enter the Weber screen by selecting **Menu | Tests | Weber**
- 2) Input and Output selections for **channel 1/channel 2** are fixed *Tone* and *Bone*.
- 3) Place the bone conductor on the patient's forehead and instruct them to tell you if the tones presented are heard better to the *Right*, *Left*, *Centre* or if it is *Not heard* at all.
- 4) Present a tone at a level of 10 dB above the worst BC threshold using the **dB HL Decrease/Increase** buttons or the PC keyboard. You can select whether you want a **Tone** or **Warble** stimulus.
- 5) Await response from the patient and click on the corresponding button above the graph.



If the patient hears the tone better in the poorer ear the hearing loss is conductive, and the tone is heard better in the better ear the hearing loss is sensorineural at the given frequency.

- 6) During the testing the frequency and intensity can be adjusted manually (see illustration).
- 7) Save the Weber test by clicking **Save** 

1.6.10 ABLB/Fowler

ABLB (Alternate Binaural Loudness Balancing) is a test to detect perceived loudness differences between the ears designed for people with unilateral hearing loss. It serves as a possible test for recruitment.

The test is performed at frequencies where recruitment is presumed. The same tone is presented alternatively to both ears. The intensity is fixed in the impaired ear (20 dB above pure tone threshold). The task of the patient is to adjust the level of the better ear until the signal in the two ears is of equal intensity. Note however that the test may also be performed by fixing the intensity in the normal hearing ear and having the patient set the tone for the impaired ear.

Required items:

- The Callisto™ hardware
- Licensed AC440 Audiometry module within your Callisto™ hardware
- Calibrated Headphones or insert phones
- A patient response button



Test procedure:

- 1) Open the AC440 module through your patient management system, Noah or OtoAccess®.
- 2) Choose settings for ABLB/Fowler using the input and output for **channel 1** and **channel 2** as illustrated below:

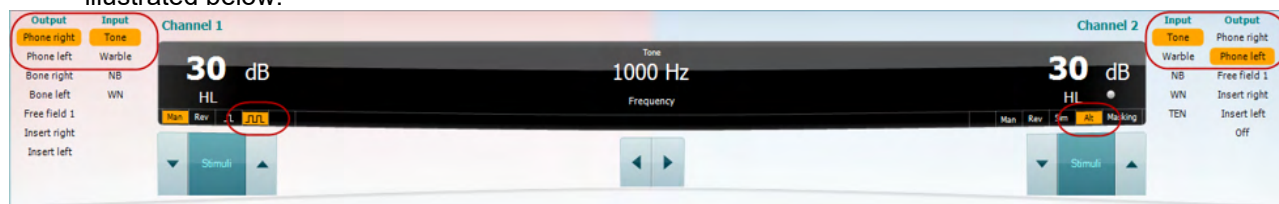

Note: **Man** (Manual) and **Multi Pulse** should be selected for channel 1 and **Alt** (Alternate) for channel 2.

- 3) Clarify the test procedure to the patient. Explain that he/she will now hear tones in both ears. The assignment is to determine when the two tones sound equal in intensity/loudness
- 4) The ABLB is performed at frequencies where recruitment is assumed. Set the intensity level on the impaired ear to 20 dB above the pure tone threshold using **channel 2**.
- 5) Adjust the intensity level in the better ear until the perceived loudness is identical to the impaired ear using **channel 1**.
- 6) Use the arrow buttons on the PC keyboard or the dedicated audiometry keyboard to set the frequency and intensity. If preferred choose **Mouse operated audiometry**  and perform the test using only the mouse. Left click to stimulate and right click to store the threshold.
- 7) The ABLB/Fowler test cannot be saved. Results must therefore be noted manually. The reporting/comment function in the AC440 software may also be of help.

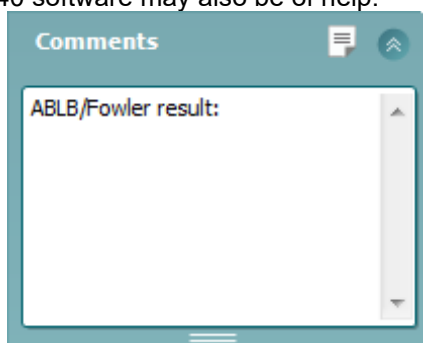

1.6.11 Stenger test

The Stenger test is applied when a patient is suspected of feigning/faking a hearing loss and is based on the auditory phenomenon, “The Stenger Principle” which states that only the louder of two similar tones presented to both ears at the same time will be perceived. As a rule, it is having been recommended to perform the Stenger test in cases of unilateral hearing losses or significant asymmetries.

Required items:

- The Callisto™ hardware
- Licensed AC440 Audiometry module within your Callisto™ hardware
- Calibrated Headphones or insert phones
- A patient response button

Test procedure for tone Stenger:

- 1) Open the AC440 module.
- 2) Choose settings for Stenger using the input and output for **channel 1** and **channel 2** as illustrated below:

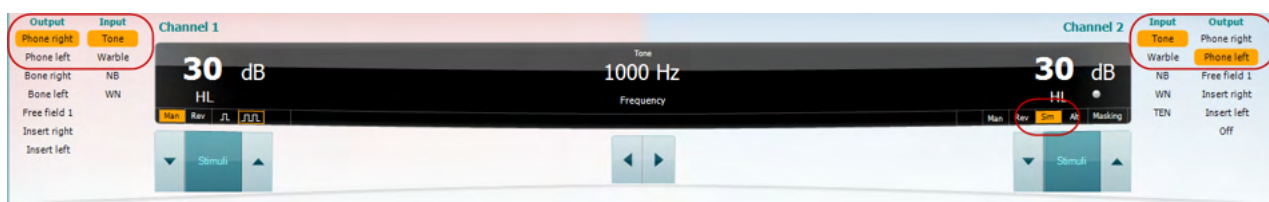

Note: **Man** (Manual) and if preferred **Multi Pulse** should be selected for channel 1 and **Sim** (Simultaneous) for channel 2.

- 3) Typically, the instruction to the patient is not different than with normal audiometry. The patient does not need to be informed that stimuli are presented at both ears simultaneously.
- 4) Use **channel 2** for presenting tones to the better ear and set the intensity level to 20 dB above the threshold.
- 5) Use **channel 1** for the poorer ear and set the intensity level 20 dB below the level of the good ear.
- 6) Present the tones to both ears simultaneously. Keep the intensity level of the better ear fixed and increase the intensity for the worse ear in 5 dB steps. If the hearing loss in the worse ear is genuine the patient will keep responding to the signal presented to the better ear (*Negative Stenger*). If the patient is feigning the hearing impairment he will stop responding when the level of the worse ear exceeds the signal presented to the good ear (*Positive Stenger*).
- 7) Use the arrow buttons on the PC keyboard or the dedicated audiometry keyboard to set the frequency and intensity. If preferred choose **Mouse operated audiometry**  and perform the test using only the mouse. Left click to stimulate and right click to store the threshold.

Test procedure for speech Stenger:

- 1) Open the AC440 module.



- 2) To perform speech tests, go to the **Speech screen**.
- 3) Choose settings for Stenger using the input and output for **channel 1** and **channel 2** as illustrated below:

Ch1 output:	Right
Ch1 input:	Mic or Wave file
Ch2 output:	Left
Ch2 input:	Mic or Wave file

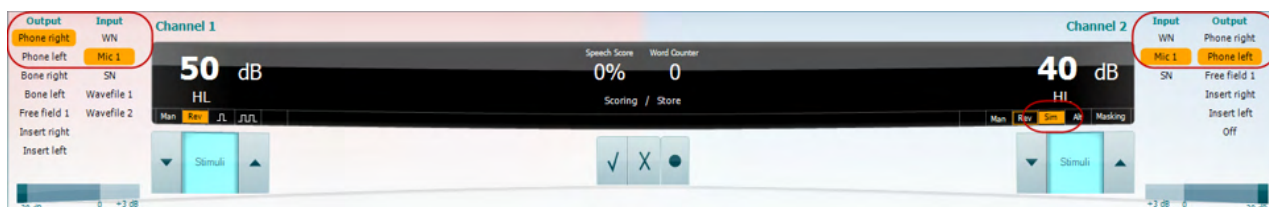

Note: **Rev** (Reverse) and if preferred **Multi Pulse** should be selected for channel 1 and **Rev** (Reverse) or **Sim** (Simultaneous) for channel 2.

- 4) Clarify the test procedure to the patient. Explain that he/she will now hear speech and the assignment is to repeat the presented words or numbers.
- 5) Use **channel 2** for presenting speech to the better ear and set the intensity level to 20 dB above the threshold.
- 6) Use **channel 1** for the poorer ear and set the intensity level 20 dB below the level of the good ear.



- 7) Present the speech material to both ears simultaneously. Keep the intensity level of the better ear fixed and increase the intensity for the worse ear in 5 dB steps. If the hearing loss in the worse ear is genuine the patient will keep repeating correctly to the speech signal presented to the better ear (*Negative Stenger*). If the patient is feigning the hearing impairment he will stop repeating correctly when the level of the worse ear exceeds the signal presented to the good ear (*Positive Stenger*).
- 8) Use the arrow buttons on the PC keyboard or the dedicated keyboard to set the frequency and intensity. You also choose **Mouse operated audiometry**  and perform the test using only the mouse. Left click to stimulate and right click to store the threshold.

1.6.12 TEN test⁹

Until recently, the TEN(HL) test for diagnosing dead regions in the cochlea could only be conducted by use of a compact disc player connected to an audiometer.

If dead regions are present, it may have important implications for fitting hearing aids and for predicting the likely benefit of hearing aids. When a patient has a dead region, there may be little or no benefit from hearing aid amplification for frequencies inside the dead region (Moore 2009). For more information regarding the TEN test please refer to Appendix 3.

Required items:

- The Callisto™ hardware
- Licensed AC440 Audiometry module within your Callisto™ hardware with TEN functionality
- Calibrated Headphones or insert phones
- A patient response button

Test procedure

The TEN Test is performed according to the methods described by Brian Moore. Please refer to Appendix 3.

1.6.13 QuickSIN¹⁰

Difficulty with hearing in background noise is a common complaint among hearing aid users. Therefore, the measurement of SNR loss (signal-to-noise ratio loss) is important because a person's ability to understand speech in noise cannot be reliably predicted from the pure tone audiogram. The QuickSIN test was developed to provide a quick estimate of SNR loss. A list of six sentences with five key words per sentence is presented in four-talker babble noise. The sentences are presented at pre-recorded signal-to-noise ratios which decrease in 5-dB steps from 25 (very easy) to 0 (extremely difficult). The SNRs used are: 25, 20, 15, 10, 5 and 0, encompassing normal to severely impaired performance in noise. For more information, please refer to Etymotic Research's *QuickSIN™ Speech-in-Noise Test* manual, version 1.3. (Appendix 4)

Required items:

- The Callisto™ hardware
- Licensed AC440 Audiometry module within your Callisto™ hardware
- Calibrated Headphones, insert phones or Free-Field Speaker

⁹ TEN test requires an additional license.

¹⁰ QuickSIN requires an additional license.



Test procedure

The screenshot shows the AC440 software interface for the QuickSIN test. The top section displays two channels (Channel 1 and Channel 2) with output levels and input waveforms. The 'QuickSIN score' is shown as 12.5. Below this is a table of SNR loss definitions. A list of 6 sentences is shown with scores for each word. A 'START' button is visible at the bottom left.

SNR Loss	Degree of SNR loss	Expected improvement with directional Mic
0-3 dB	Normal / near normal	May hear better than normals in noise
3-7 dB	Mild SNR loss	May hear almost as well as normals in noise
7-15 dB	Moderate SNR loss	Directional microphones help. Consider array mic
>15 dB	Severe SNR loss	Maximum SNR improvement is needed. Consider FM system

Score
5
4
3
1
0
0
Total 13
25.5 - TOTAL = SNR loss 12.5

- 1) Open the AC440 and enter the QuickSIN screen by selecting **Menu | Tests | QuickSIN**
- 2) Select the output level. For most of the tracks the channels are synchronised to ensure that the correct SNR level is achieved. Note: the 'Speech and Babble' Lists are not synchronised and will require the user to manually alter these to ensure the correct SNR setting for the test.
- 3) Select a list in the corresponding dropdown. e.g., "QuickSIN (List 2)".
- 4) Instruct the patient to repeat the sentences and try to ignore the noise that they will also hear through the headphones.
- 5) Press **START** to begin the test
- 6) The number of words in bold the patient repeats correctly should be scored by clicking on the score buttons.
- 7) When 6 sentences are scored a total score will be calculated.
Note that if you press **Stop** before the 6 sentences of the list have been played and scored, no total score will be calculated.
- 8) The total score can be compared to the "SNR loss definitions".
- 9) Save the QuickSIN test by clicking **Save** 

Aided QuickSIN is possible by selecting the free field transducer.

To activate Aided QuickSIN:

1. Ensure you are in the QuickSIN screen
2. Select Free Field as the Transducer; this will activate the "Aided" function.
3. Click on the Aided button; this will add an extra column on to the QuickSIN scoring table



SNR Loss	Degree of SNR loss	Expected improvement with directional Mic	Add text here
0-3 dB	Normal / near normal	May hear better than normals in noise	click on the dropper to add colour
3-7 dB	Mild SNR loss	May hear almost as well as normals in noise	
7-15 dB	Moderate SNR loss	Directional microphones help. Consider array mic	
>15 dB	Severe SNR loss	Maximum SNR improvement is needed. Consider FM system	

Item	S/N	Score
1. A white silk jacket goes with any shoes	25	3
2. The child crawled into the dense grass	20	
3. Footprints showed the path he took up the beach	15	
4. A vent near the edge brought in fresh air	10	
5. It is a band of steel three inches wide	5	
6. The weight of the package was seen on the high scale	0	
Total		3

Comparing aided and unaided QuickSIN scores over time:

Clinicians are now able to compare the Unaided and Aided SNR scores.

To view the scores in a graph view, click on the graph icon

To view the scores in a graph view, but using the patient monitor, click on Patient Monitor

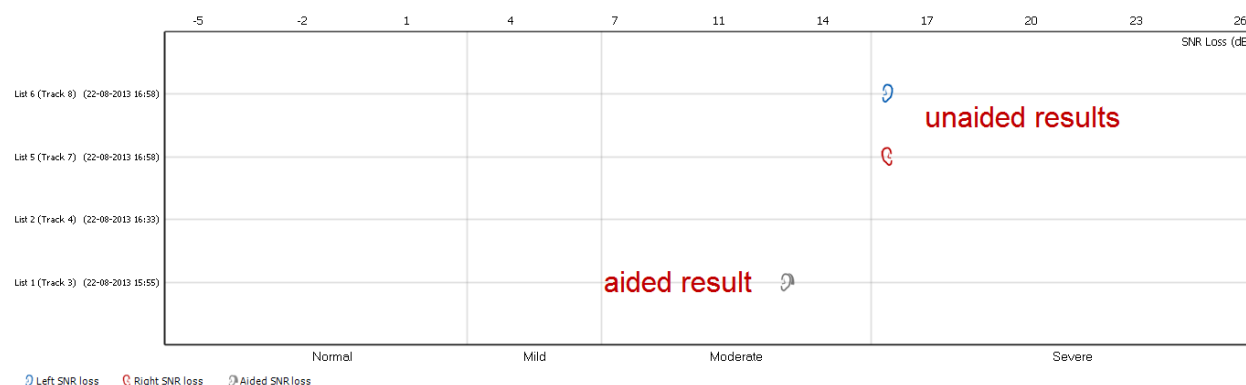

The QuickSIN is performed according to the methods described in the QuickSIN manual. Please refer to Appendix 4.



1.6.14 Tone decay¹¹

This is a test to help identify the adaptation of the auditory system (Carhart, 1957). It involves measuring the perceptual reduction in a continuous tone over time. This can indicate towards a cochlear or neural cause of deafness.

The test involves looking at the patient's response to the onset of a supra-threshold sound and then their continuous response to this as it continues over time. For example, in Meniere's disease this is detected correctly on onset but rapidly deteriorates due to dysfunctional hair cells (Carhart, 1957). A normal response should be maintained for a minute of stimulation, should a patient not be able to maintain this then the stimulus intensity is increased until a minute is achieved. This is only increased up to a maximum 30 dB supra-threshold.

Previously this test could only be administered manually with the Callisto™ Suite and a stopwatch but now we have added this test to the software for ease of use.

Required items:

- The Callisto™ hardware
- Licensed AC440 Audiometry module within your Callisto™ hardware
- Calibrated Headphones or insert phones

Test procedure

1. The patient's Audiometry is obtained.
2. The patient is then instructed to continuously respond to the tone if they hear it and not respond as the signal fades/is absent.
3. The test is administered with a pure tone 5 dB below the subject's established threshold and then ascended in 5 dB steps without interruption until the subject responds. As soon as the subject responds, the system will begin timing (this is shown in the image below). If the tone is heard for a full one minute, then the test is stopped.

¹¹ Tone decay requires an additional license

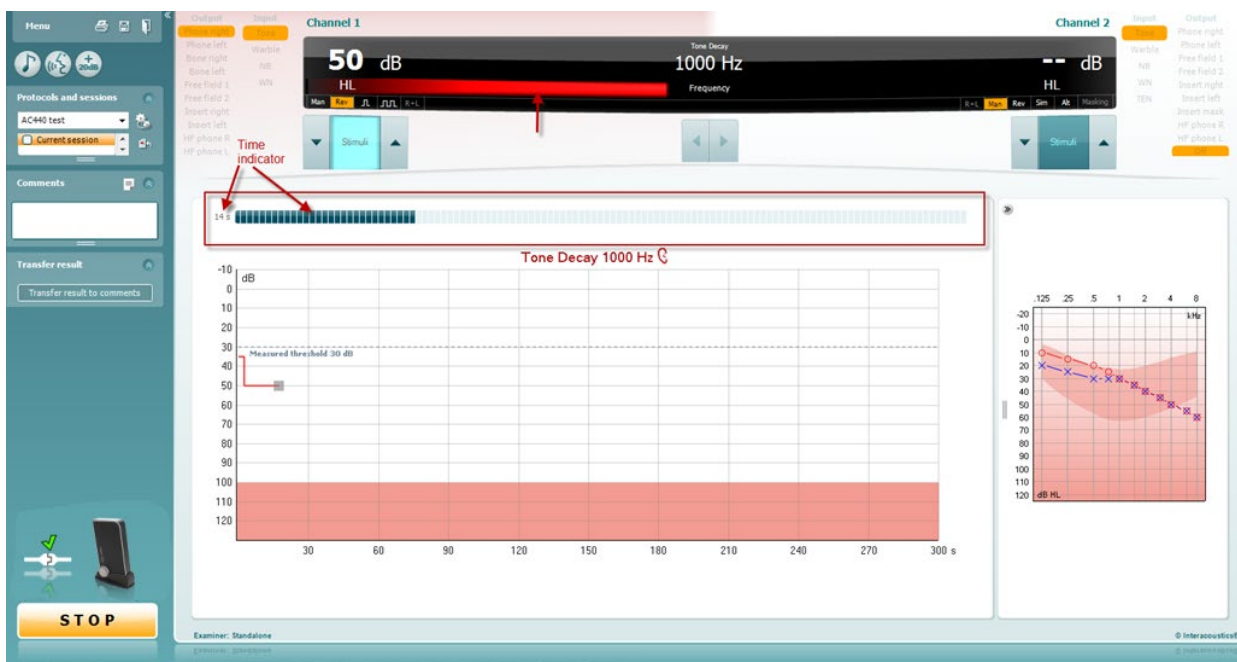
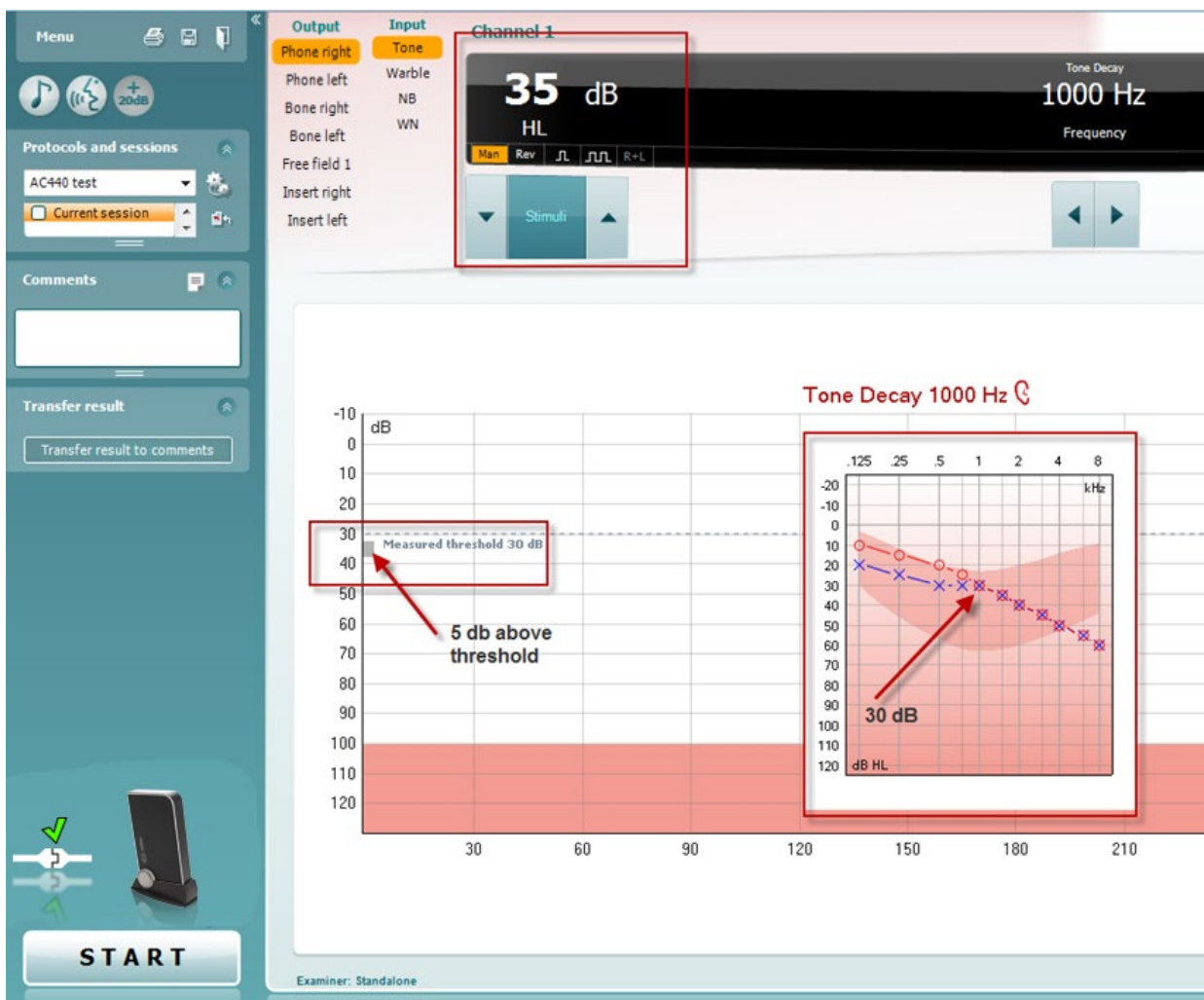



4. But if the subject indicates that they no longer hear the tone before the minute criteria is reached, then the intensity of tone is increased by 5 dB without interrupting the tone, but the timing at the top of the screen is reset.
5. The tone is continued to be raised in 5 dB steps until an intensity is reached that allows the subject to perceive the tone for full minute. The amount of decay occurring at each level suggests/indicates the amount of decay the subject is showing.
6. As a time saving measure, Carhart (1957) suggested that the test should be terminated when the subject fails to respond 30 dB above threshold.

Once this measurement has been finished the data can be documented as a comment to the session by the 'Transfer result to comments' on the left of the screen. Alternatively, it can be saved via the disk or door icon in the top left for review later.

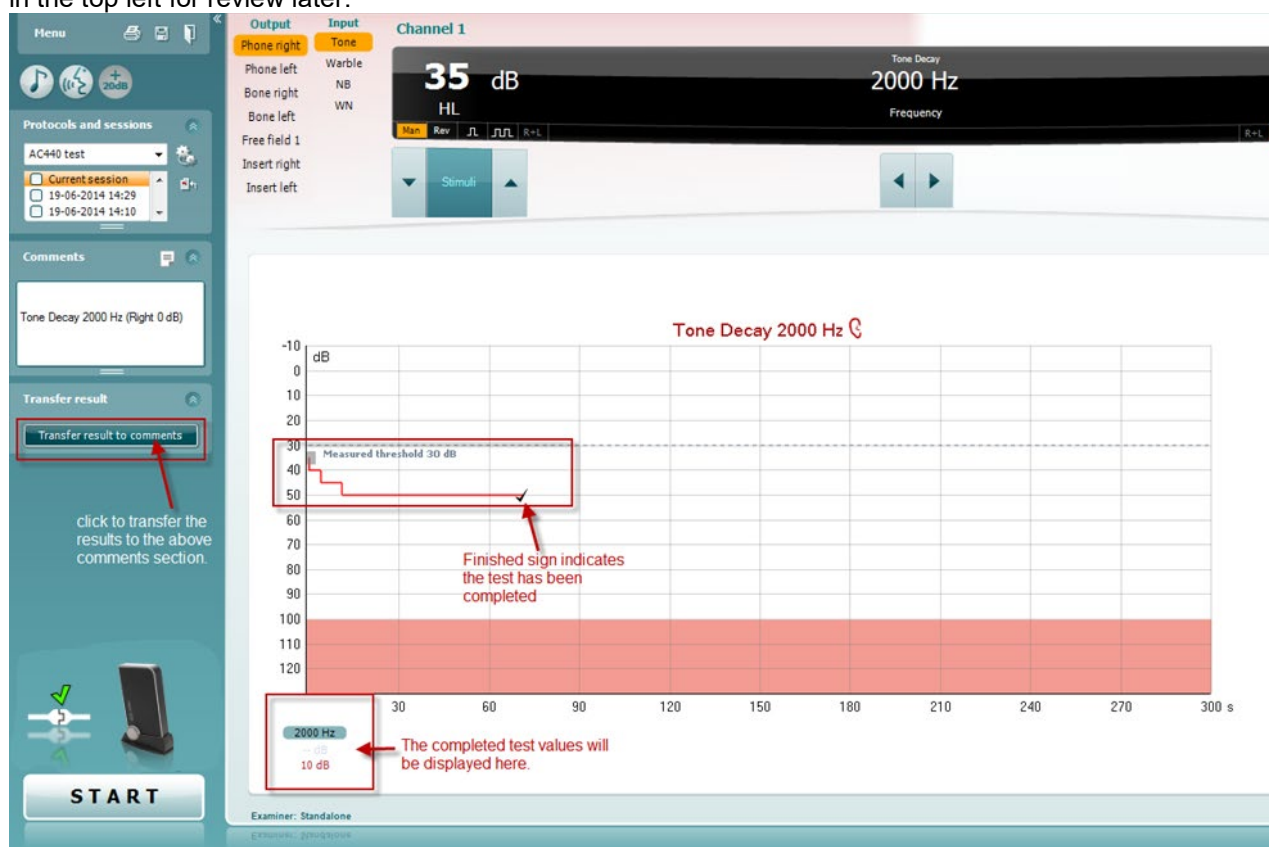



1.6.15 ANL test¹²

The Acceptable Noise Level (ANL) Test is a method of determining how much noise the patient can tolerate whilst listening to a target signal/speaker (Nabalek et al., 1991). It is used as a predictor for how well a patient will cope with amplification when receiving a hearing aid (Nabalek et al., 2006).

The ANL test is designed to be performed via loudspeaker as it is a free field test. However, it can be configured to perform monaurally via selection of headphones and routing the signal to the relevant ear-side. The Equinox and Affinity systems can perform the test binaurally via the R+L feature.

The ANL Test can use any of the materials you have already ripped into your Interacoustics Suite software.

When should I perform the ANL test?

The ANL test is typically performed before the patient is given any form of amplification as a rehabilitative action for their hearing loss.

Test procedure

1. Launch the Affinity²/Callisto™ Suite from Noah or OtoAccess®.
2. Click on the **AUD** tab on the upper right-hand side of the screen. Ensure that your Audiometry has been performed ahead of advancing into the SIN test as this determines the start level for the test.
3. Click on **Menu, Tests** and then select **ANL**

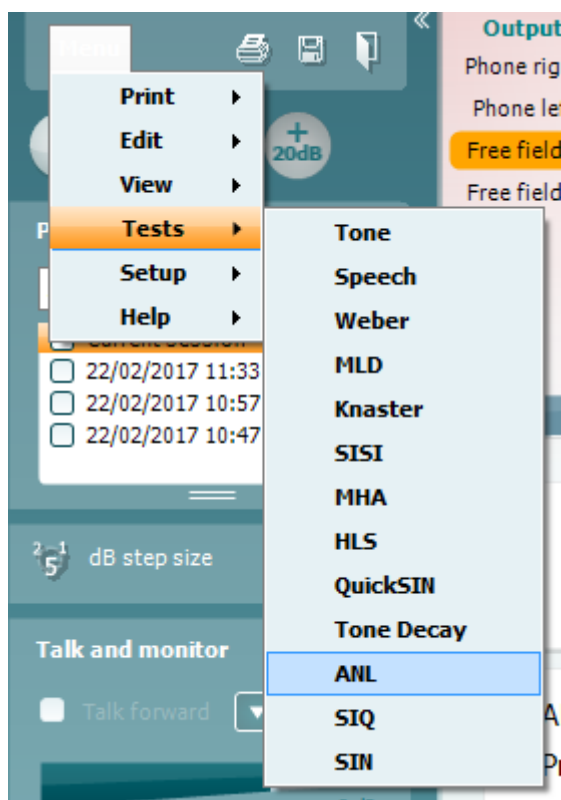

4. Once in the ANL test screen, you will see that there are 4 different conditions which you can choose to measure.
MCL High – This is the loudest comfortable level the patient can listen to without any competing noise
MCL Low – This is the lowest comfortable level the patient can listen to without any competing noise

¹² The ANL Test requires an additional license.



MCL Real – This is the patient most comfortable level without any competing noise
BNL – This is the actual ANL test where the MCL Real is presented, and the competing noise is manipulated to find an ANL value
It is not essential to perform MCL High and MCL Low for the ANL test, but these are also good indicators of the patients' comfortable hearing range.
Instructions for the patient will always be displayed at the bottom of the screen.

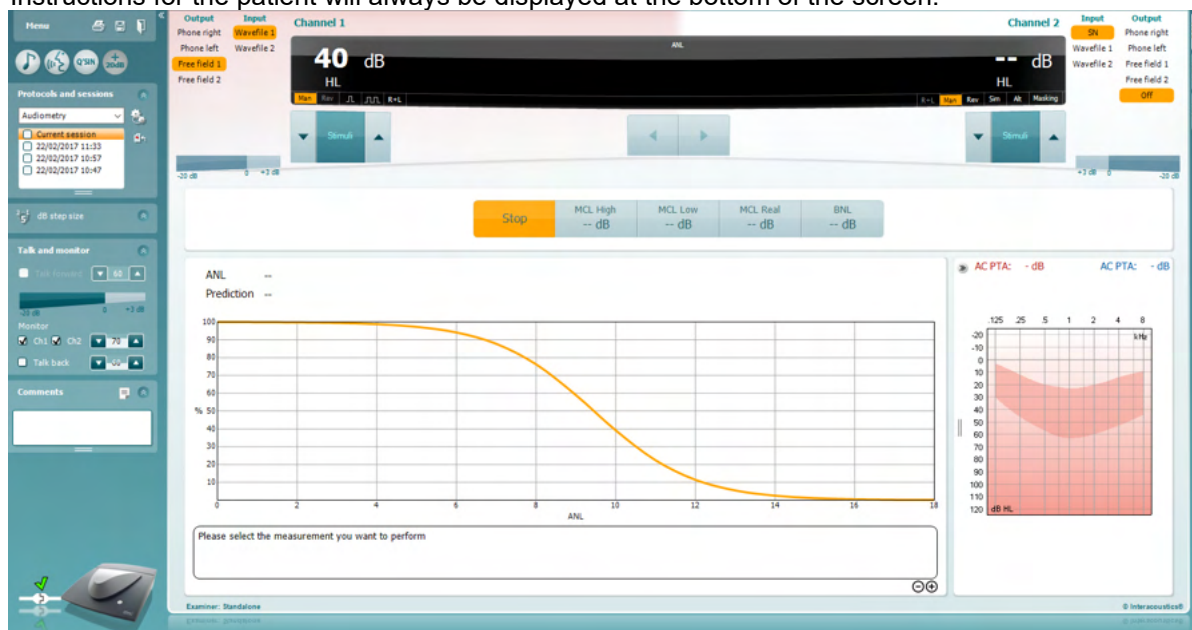

5. MCL High

Click on the MCL High Icon and click play. This will loop your speech material.

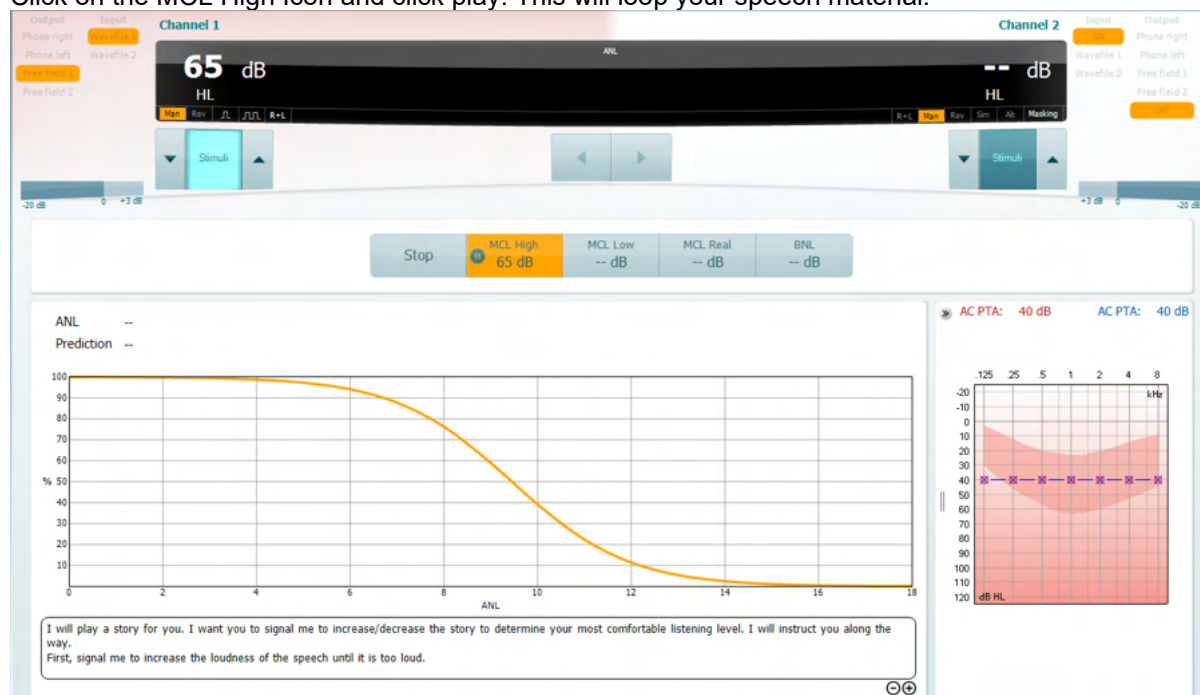

Increase and decrease the stimulus intensity to match the patients loudest MCL.
There will be no other change in the display to represent this, only the level in the MCL High icon box.



6. MCL Low

Click on the MCL Low Icon and click play. This will loop your speech material.

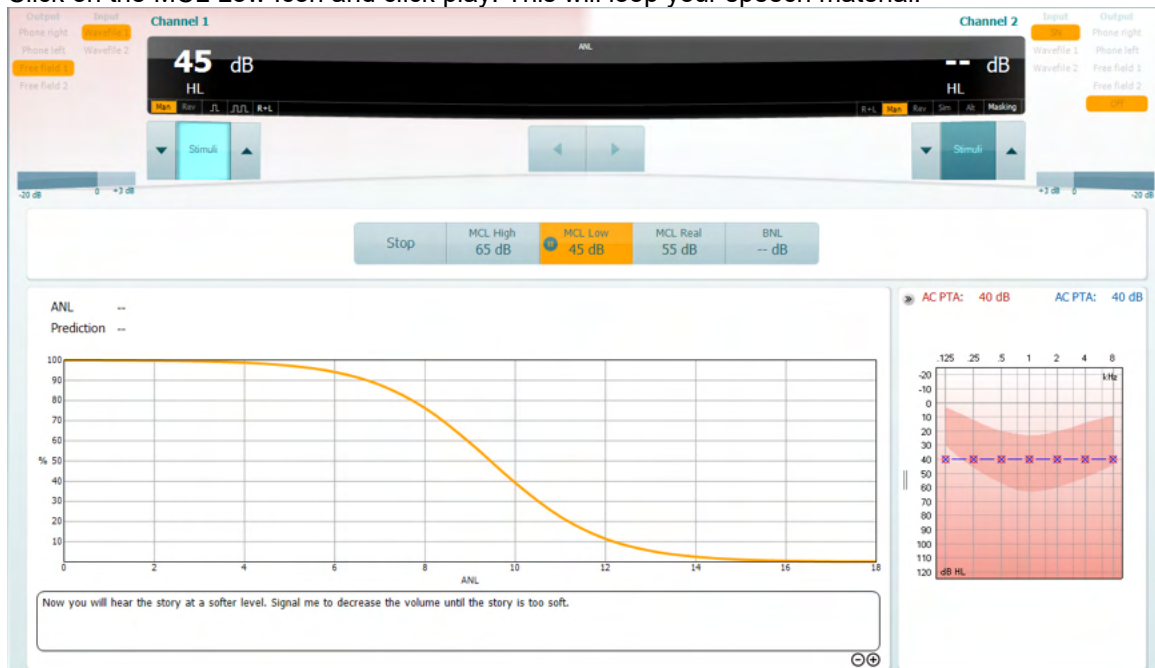

Increase and decrease the stimulus intensity to match the patients lowest MCL.

The display will change within the icon but also a predicted MCL Real will be generated as a midpoint between the MCL High and MCL Low.

7. MCL Real

Click on the MCL Real Icon and click play. This will loop your speech material.

If you have performed the MCL High and MCL low, you should already have a predicted MCL value here. If not, then increase/decrease the intensity to find a suitable level for the patients MCL.

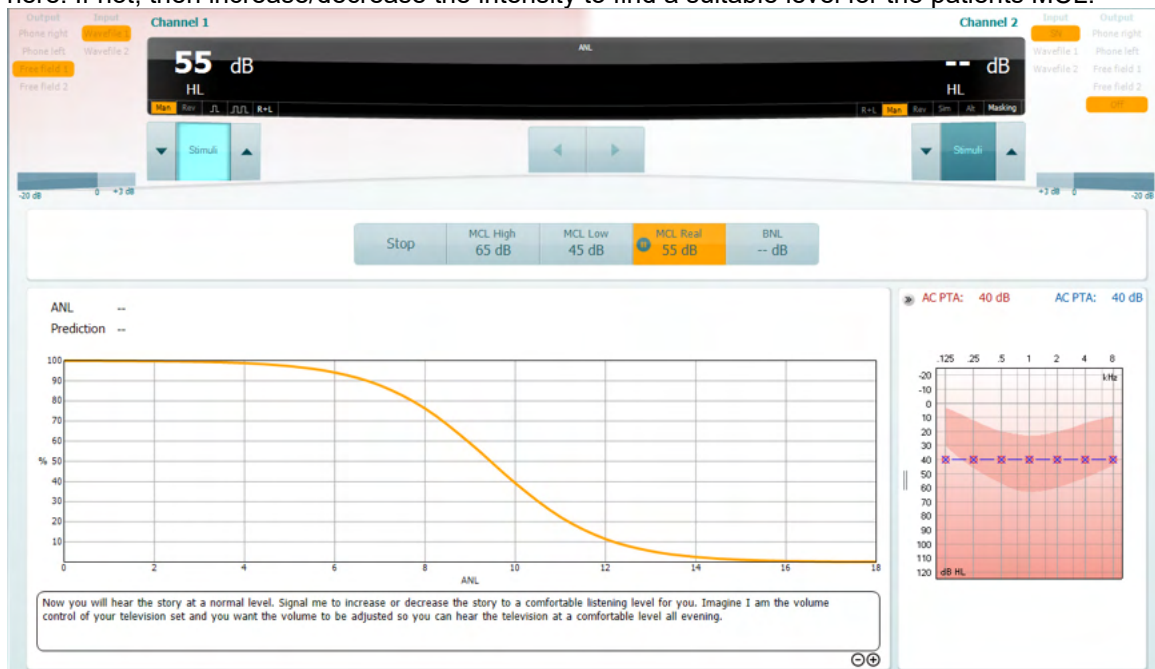

Again, the display will not change, other than inside the icon for your test condition.



8. BNL

Click on the BNL Icon and click Play. This will loop the same speech material but also introduce the background masking noise.

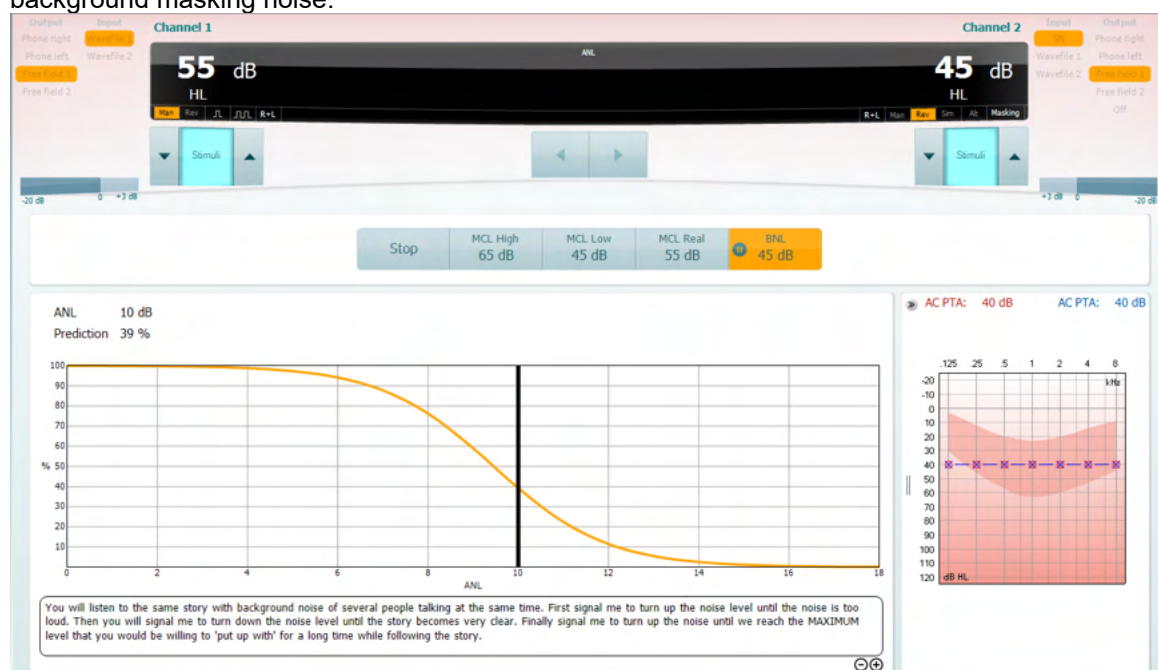

Increase/decrease Channel 2 to find a level of competing noise which the patient would be comfortable to listen to alongside their target material. Whilst doing this you will notice the display will change to reflect the patients ANL value and the prediction percentage of how well they will perform with amplification.

NOTE: You can customise the instructions displayed in the test screen by entering the ANL setup.

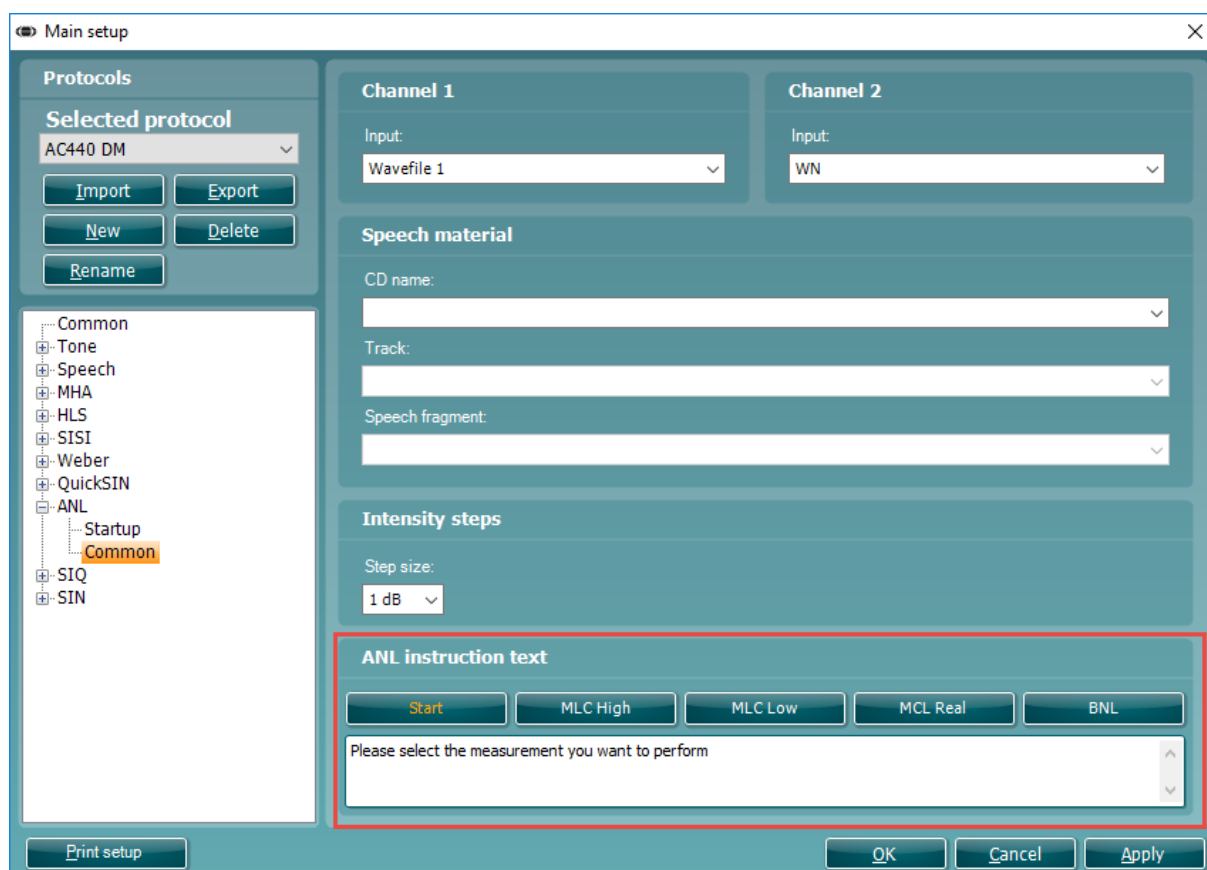

What does my ANL value mean?

On performing the ANL test you will obtain an ANL value (in dB) and a percentage. The percentage gives a likelihood of success with amplification (Nabalek et al., 2006) and the ANL value is the outcome of the following calculation:

$$\text{ANL} = \text{MCL} - \text{BNL}$$

For response categories the following outcome criteria was determined as an effect of the Nabalek et al. (2006) investigation into ANL outcomes in relation to amplification:

ANL Score 7 dB or less: These individuals have a great prognosis for regular use and acceptance of hearing aids; may not need as much follow-up counseling and guidance as the average patient.

ANL Score 8-12 dB: These are your more common patients and have a good (8) or bad (12) prognosis for regular use and acceptance of hearing aids. These patients may need more follow-up counseling and are excellent candidates for noise reduction technologies.

ANL Score 13 dB or more: These patients are “at risk” for reduced utilization of hearing aids and may need additional post-fitting counseling, guidance, and require noise reduction technologies.



1.6.16 SIQ test

The Speech in Quiet (SIQ) test is a method of testing a patient's functional hearing in the absence of any competing sound. The objective of this is to identify their functional hearing ability (Schoepflin, 2012). The outcome of this investigation will give a Speech Recognition Threshold (SRT).

This type of testing is different from Tone Audiometry as it involves higher areas of the Auditory pathway as the information needs to be heard, processed, and repeated to give a correct response (National Research Council (US), 2004).

The SIQ test is designed to be performed via loudspeaker as it is a free field test. However, it can be configured to perform monaurally via selection of headphones and routing the signal to the relevant ear-side.

The SIQ test is very similar to Speech Audiometry and can use any of the materials you have already ripped into your Interacoustics Suite software. However, the Stimulus intensity is maintained automatically by the software following a correct or incorrect response to the stimulus, this helps to speed up the test time.

When should I perform the SIQ test?

It is normal to perform this following Tone Audiometry as it gives a good indicator of the patient's performance for speech, it can also be a good indicator of the accuracy of your audiogram (Mehta & Singh, 2000). It can also be used before and after the provision of hearing aids to give an identification of the benefit achieved through amplification (REF).

Test procedure

1. Launch the Affinity²/Callisto™ Suite from Noah or OtoAccess®.
2. Click on the **AUD** tab on the upper right-hand side of the screen. Ensure that your Audiometry has been performed ahead of advancing into the SIN test as this determines the start level for the test.
3. Click on **Menu, Tests** and then select **SIQ**

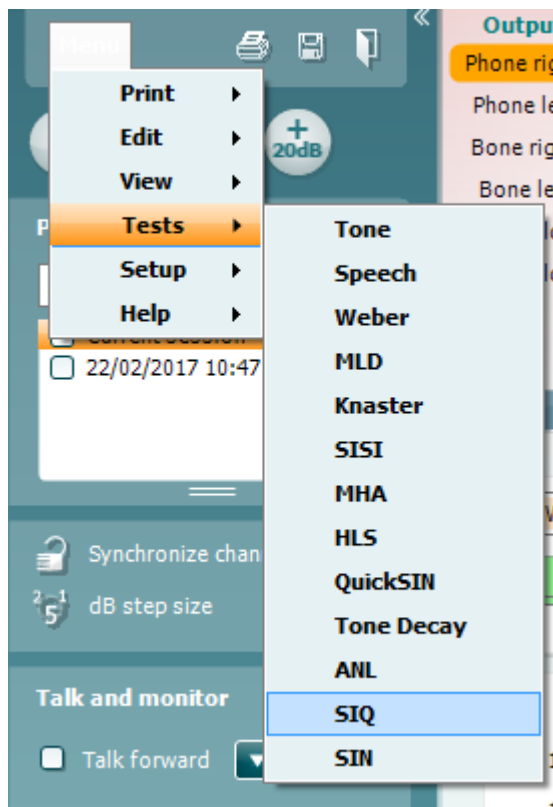



- Once in the SIQ test screen, the stimuli levels should be set for you. These are based on the patient audiogram and the PTA score.



- Ensure that your speech material is correct, and the relevant list has been chosen.
- Instruct the patient to respond by repeating the words that they hear. Press the play icon to begin the test.
- On the patients' response, score the words correct or incorrect according to their response. The system will automatically increase the next stimulus intensity for an incorrect response and decrease the next stimulus intensity for a correct response.
- Repeat this procedure until your word list has completed. The system will automatically store on completion of your word list.

1.6.17 SIN test

The Speech in Noise (SIN) test is a method of testing a patient's functional hearing in the presence of competing sound (Taylor, 2003). The objective of this is to identify their functional hearing ability and higher processing which allows them to sort between useful (speech/signal) and irrelevant (noise/masking) information (Taylor, 2003). The outcome of this investigation will give a Speech Recognition Threshold (SRT) for a varying Signal to Noise Ratio (SNR).

This type of testing is different from Tone Audiometry as it involves higher areas of the Auditory pathway as the information needs to be heard, sorted, and understood to determine if it is useful or not (Marrone et al., 2008).

The SIN test is designed to be performed via loudspeaker as it is a free field test. However, it can be configured to perform monaurally via selection of headphones and routing the masking to the same output.

The SIN test is very similar to Speech Audiometry and can use any of the materials you have already ripped into your Interacoustics Suite software. However, the Signal-to-Noise Ratio is maintained automatically by the software following a correct or incorrect response to the stimulus, this helps to speed up the test time.

When should I perform the SIN test?

It is normal to perform this following Tone Audiometry as it gives a good indicator of the patient's performance for speech in noise. It can also be used before and after the provision of hearing aids to give an identification of the benefit achieved through amplification (Marrone, Mason and Kidd, 2008).



Test procedure

1. Launch the Affinity²/Callisto™ Suite from Noah or OtoAccess®.
2. Click on the **AUD** tab on the upper right-hand side of the screen. Ensure that your Audiometry has been performed ahead of advancing into the SIN test as this determines the start level for the test.
3. Click on **Menu, Tests** and then select **SIN**

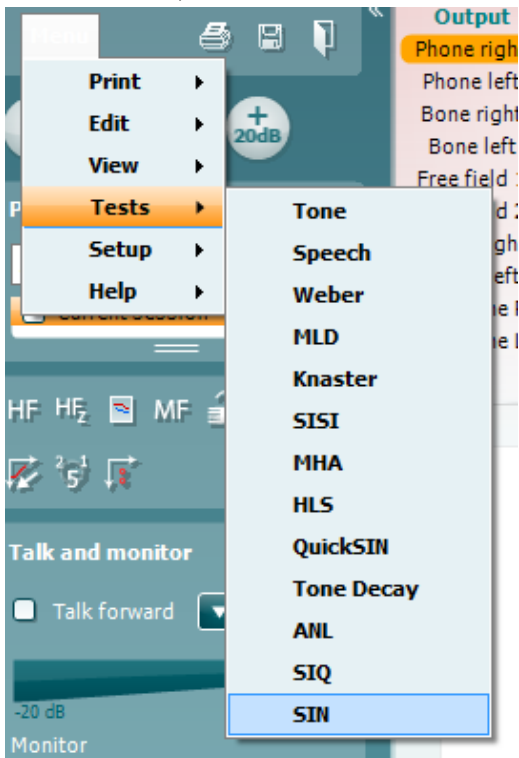

4. Once in the SIN test screen, the stimuli levels should be set for you. These are based on the patient audiogram and the PTA score.

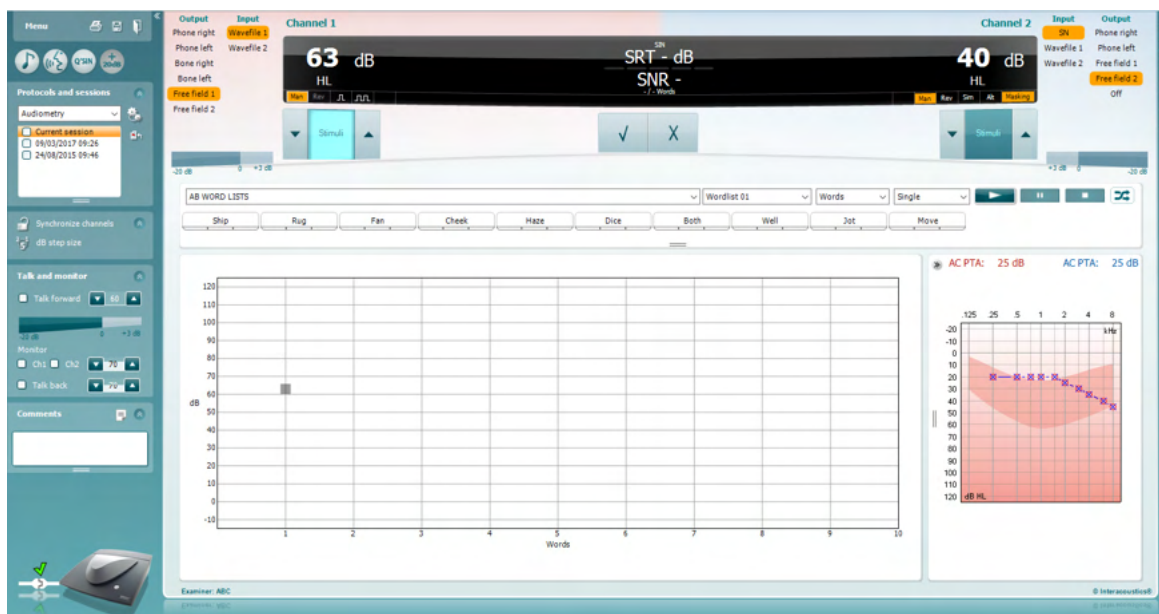

5. Ensure that your speech material is correct, and the relevant list has been chosen.



6. Turn on the masking in Channel 2 by clicking from **Man** to **Rev**. The masking will need to be turned on manually, this is because you may want to perform an initial familiarization test with the patient without the noise to begin.
7. Instruct the patient to respond by repeating the words that they hear. Press the play icon to begin the test.
8. On the patients' response, score the words correct or incorrect according to their response. The system will automatically increase the next stimulus intensity for an incorrect response and decrease the next stimulus intensity for a correct response.
9. Repeat this procedure until your word list has completed. The system will automatically store on completion of your word list.



1.6.18 VDB-express

Difficulty with hearing in background noise is a common complaint among hearing aid users. Therefore, the measurement of SNR loss (signal-to-noise ratio loss) is important because a person's ability to understand speech in noise cannot be reliably predicted from the pure tone audiogram. The VDB-Express test was developed to provide a quick estimate of SNR loss for French listeners. A list of nine sentences with three key words per sentence is presented in speech babble noise. The sentences are presented at pre-recorded signal-to-noise ratios (SNR) which decrease in 3-dB steps from -18 dB (very easy) to 3 dB (extremely difficult). The SNRs used are: -18, -15, -12, -9, -6, -3, 0 and 3 dB, encompassing normal to severely impaired performance in noise.

Required items:

- The Callisto™ hardware
- Licensed AC440 Audiometry module within your Callisto™ hardware
- VDB-Express License in your Callisto™ hardware
- Calibrated Headphones, insert phones or Free-Field Speaker



Test procedure

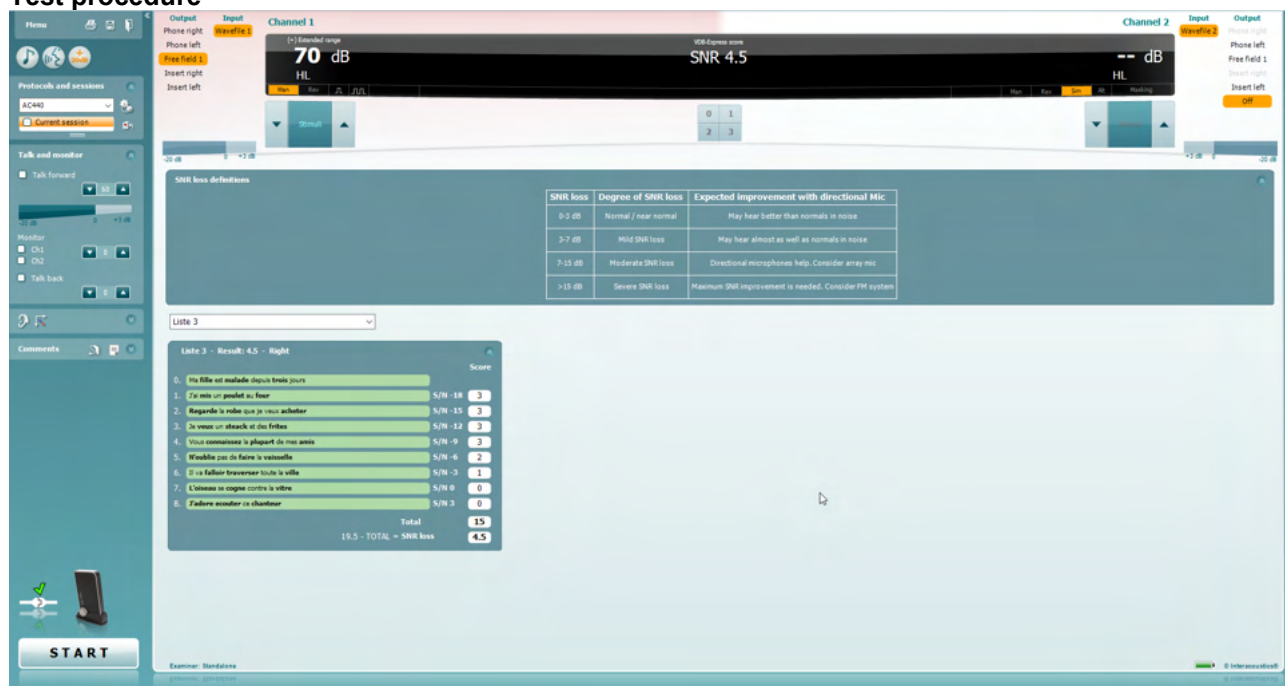

- 1) Open the AC440 and enter the VDB-Express screen by selecting **Menu | Tests | VDB-Express**

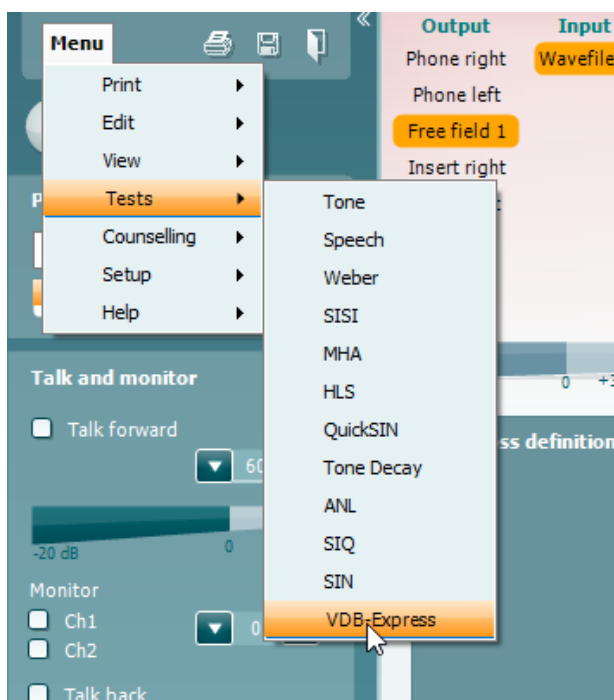

- 2) Select the output level. The channels are synchronised for this material to ensure that the correct SNR level is achieved.
- 3) Select a list in the corresponding dropdown. e.g., "List 2".
- 4) Instruct the patient to repeat the sentences and try to ignore the noise that they will also hear through the headphones.
- 5) Press **START** to begin the test
- 6) The first sentence is always a practice sentence, and its score will not contribute to the result calculation.



- 7) The number of words in bold the patient repeats correctly should be scored by clicking on the score buttons. Scoring is disabled until the sentence has been played completely.
- 8) When 9 sentences are scored a total score will be calculated.
Note that if you press **Stop** before the 9 sentences of the list have been played and scored, no total score will be calculated.
- 9) The total score can be compared to the “SNR loss definitions”.
- 10) Save the VDB-Express test by clicking **Save** 

Aided VDB-Express is possible by performing through a free field transducer.

To activate Aided VDB-Express:

1. Ensure you are in the VDB-Express screen
2. Select Free Field as the Transducer; this will activate the “Aided” function.
3. Click on the Aided button; this will add an extra column on to the VDB-Express scoring table.

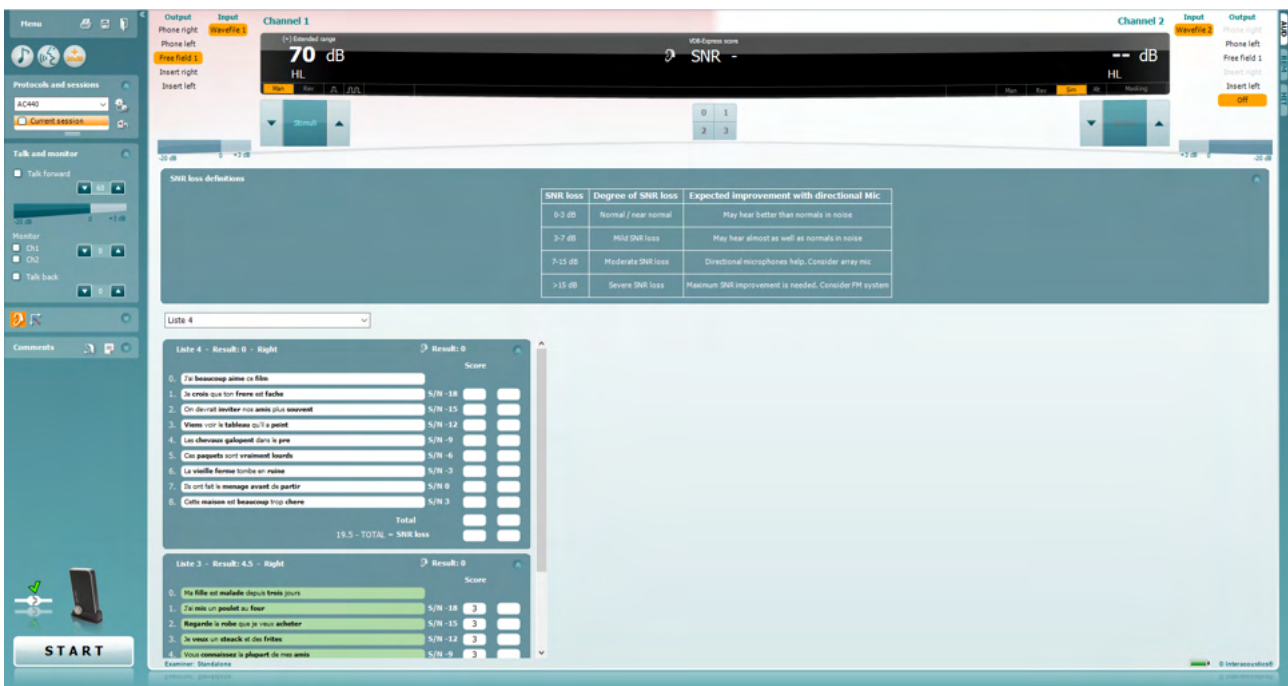

Comparing Aided and Unaided VDB-Express scores over time:

Clinicians are now able to compare the Unaided and Aided SNR scores.

To view the scores in a graph view, click on the graph icon 

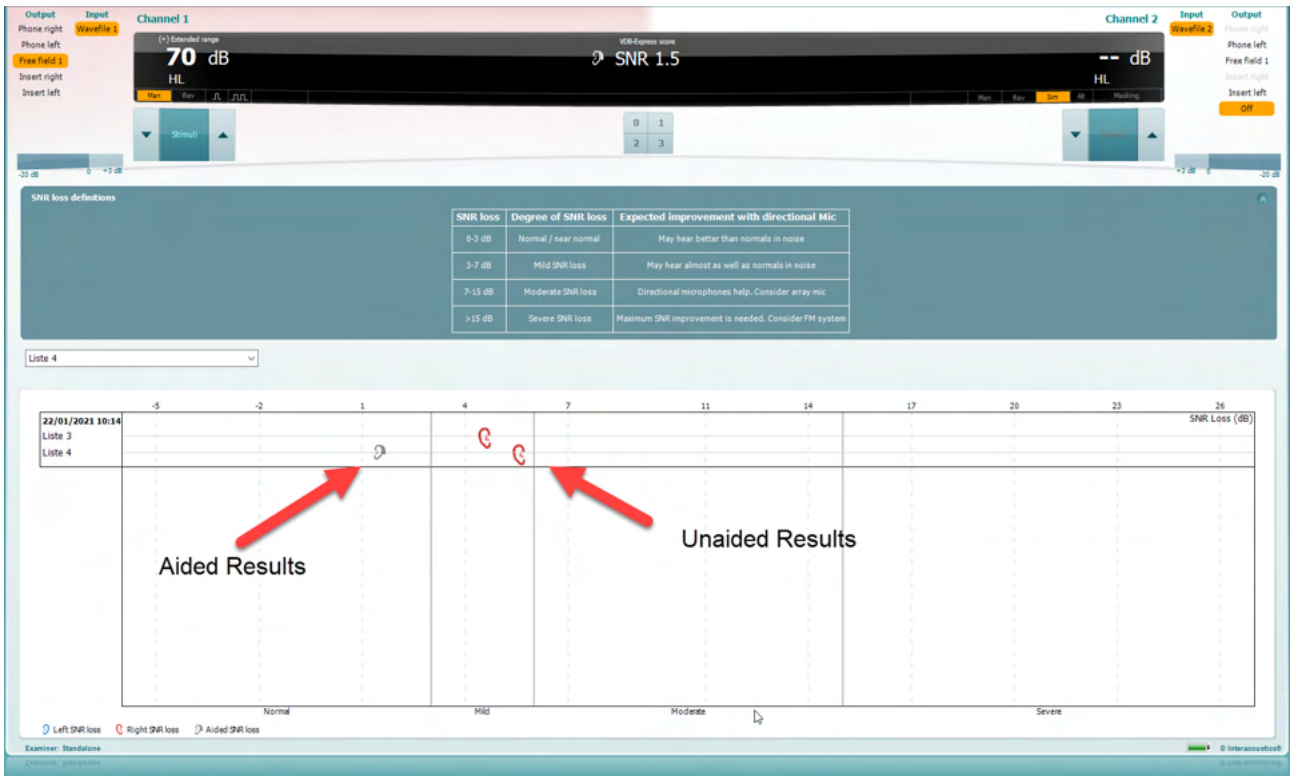



1.6.19 The Audible Contract Threshold (ACT™) Test

What is the ACT test?

The ACT diagnostic test is an above-threshold, non-language specific test that quantifies a person's real-world ability to hear in noise.

The test applies the shape and levels of the audiogram to ensure the correct stimulus intensity is applied. When we get an audiogram, it allows us to objectively map out a person's hearing thresholds. ACT then applies this person's audiogram to deliver an above-threshold stimulus (a siren-like sound) to objectively map their hearing-in-noise ability.

In other words, where the audiogram measures the quantity of hearing, ACT measures the quality of hearing. This way, we have a robust assessment that reflects a person's real-world hearing abilities.

Once you have obtained the ACT value, you can use it to counsel your client on their speech-in-noise ability. It also provides you with advice on how best to support your client to hear better in noisy environments.

ACT is performed unaided. However, due to the test being conducted at above-threshold intensity, you can get a clearer understanding of how well your client will perform with hearing aids when in noisy situations. There is also the possibility to prescribe help in noise in selected hearing aids.

The ACT value is denoted as dB nCL which stands for 'normalized Contrast Level.' This is a novel scale developed by the research team at the Interacoustics Research Unit (IRU). In brief, the background definition of nCL stands for:

- **n** (normalized): the scale is normalized based on normative data acquired from young, normally hearing people
- **C** (contrast): clients are detecting a contrast in the modulation of a signal
- **L** (level): this is a dB measure and is denoted as such

Pre-test counselling guidance

You can perform ACT on any adult client that you deem suitable to perform pure tone audiometry. It may be useful to counsel the client on the reason for performing ACT. Here, you will find an example script.

"We will perform a test called ACT. The result from this test will clarify your abilities to hear in background noise. This can be challenging, particularly if you have a hearing loss. So, performing this test will help me to know to what degree this is also a challenge for you."

Required equipment

To perform an ACT test, you will need:

- Affinity Compact or Callisto
- Patient response button
- Connected PC and keyboard
- Headphones or insert earphones
- Licensed AC440 audiometry module including an ACT license

Points to note

It is recommended that you listen to the acoustic stimuli over monitor headphones during the test. This will help you to present the target stimuli in an unpredictable manner.

To perform ACT, you must complete an audiogram for air conduction at the following frequencies:

- 250 Hz, 500 Hz, 1000 Hz, 2000 Hz, 4000 Hz
- Inter-octave frequencies will be considered in ACT testing if they have been completed.

Should the following notification appear: *'Insufficient data to complete the test'*, please ensure all mandatory thresholds have been stored for both ears. A 'no response' will be factored into the ACT test, but a 'Could not test' or 'Did not test' will be excluded and you will not be able to complete the ACT test.

When in simulation mode of the suite, it is only possible to view historical data.

ACT test procedure

1. Launch your Affinity/Callisto Suite into AUD mode.
2. Ensure there is an audiogram inserted into the current session.
3. Click on 'Menu'.
4. Click on 'Test.'
5. Select ACT.
6. The ACT instructions will pop up in a separate window.
7. Read the instructions to the client.



8. Use the 'sound examples' to demonstrate and explain the test procedure. You can play these sound examples as many times as is necessary to familiarize the client.
9. Once you are confident that the client has understood the test, click 'Proceed to test'.

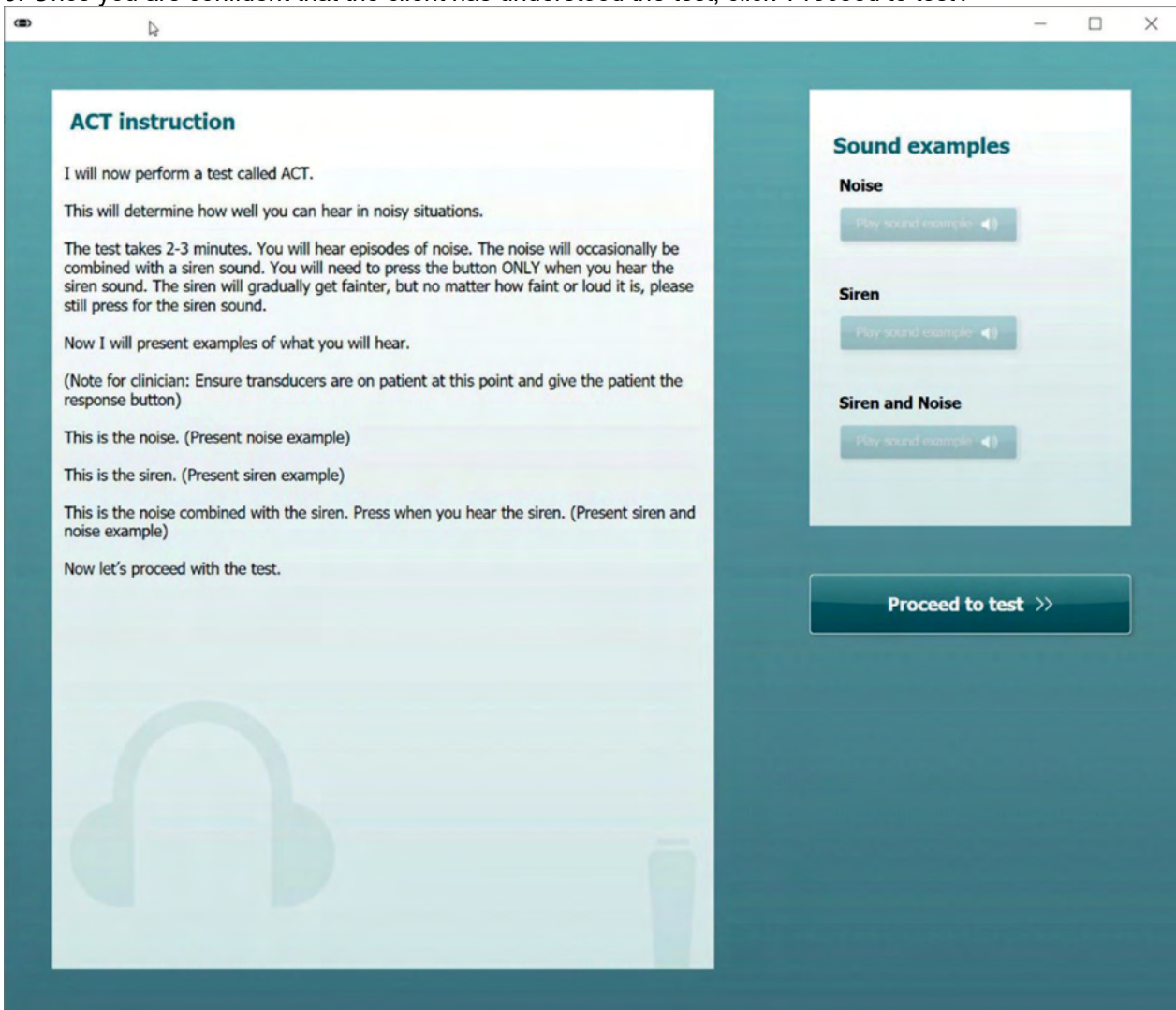

ACT instruction

If you wish to read instructions again at any point, click on 'i' in the left-hand menu.

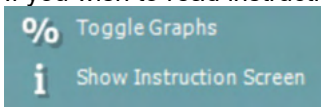

Show instruction screen

10. Press START.
 - a. A sequence of noise episodes will start.
 - b. You perform the test in the same way as pure tone audiometry using the Hughson-Westlake adaptive method (2 down, 1 up) with a 3 out of 5 criteria, as described in the ACT flowchart.
 - c. Present the stimulus by clicking once on your chosen presentation key. If you press 'spacebar' to present a stimulus, press this once. DO NOT press and hold.
 - d. A black dot appears automatically when the client correctly hears the target stimulus.
 - e. A white dot appears automatically when the client has not heard the stimulus or has not responded in the viable time frame.



OPTIONAL: If you are not confident that your client knows when to respond after presenting the sound examples within the instruction box, try starting the test and perform 3 presentations at 16 dB nCL. Then continue as in step 10.

11. Once the required number of thresholds has been reached to produce an ACT value, the test will automatically stop. The calculated ACT value is then stored in the middle of the green band across the screen.

Points to consider:

- You can stop the test at any point by pressing the 'STOP' button.
- If the test exceeds 25 presentations (indicated as a line on the trace), there is a higher risk of client fatigue. Please refer to scenario 3 below for guidance on how to address this.

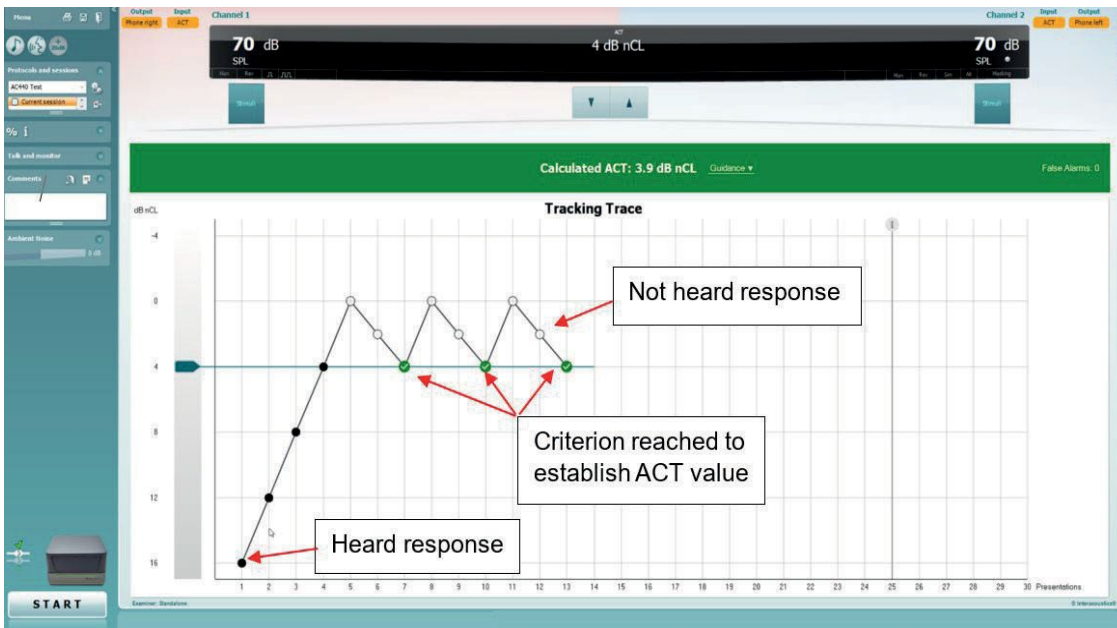

Example traces

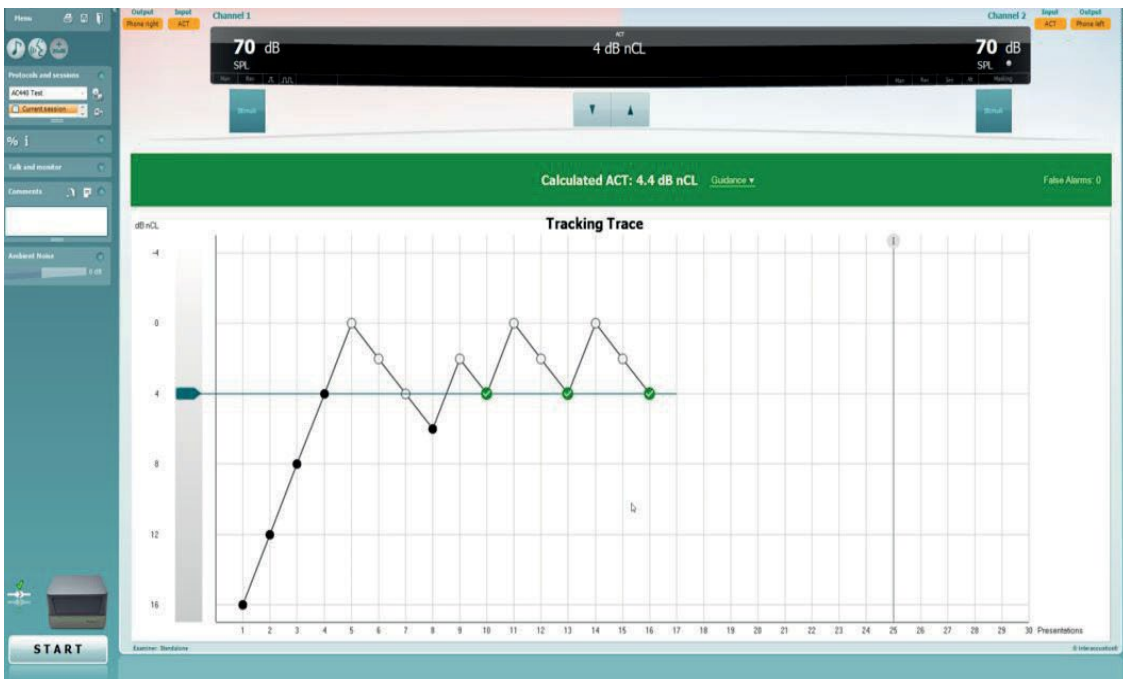

Example traces



Scenarios

Guidance on what to do in case of inconsistent responses during the test

Every client is different and may not follow normative patterns when conducting ACT. The following pages show some examples on what you can do based on irregular responses

Scenario 1: Client keeps pressing response button despite no stimulus

The client has many false positives (responds at the right time but has not heard the signal) or presses the button too often. To solve this, increase the nCL to 4 dB nCL above the expected threshold (or even higher) to remind the client what to listen for and return to the previous level.

Calculated ACT: 2.9 dB nCL

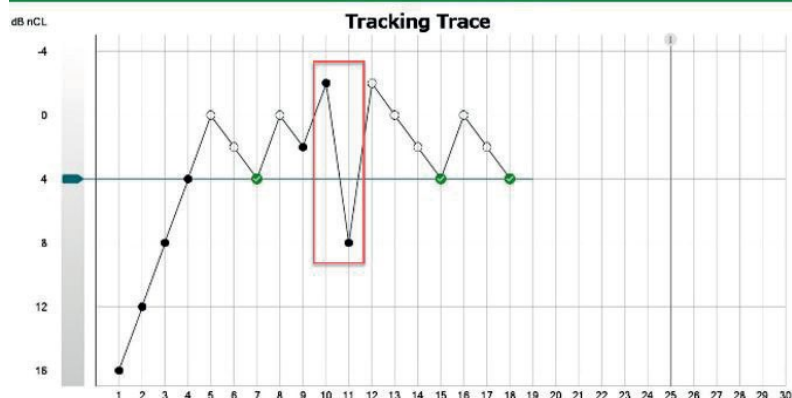

nCL increase 4 dB

Scenario 2: Client is losing concentration

The client is close to obtaining a threshold but loses concentration and fails to respond at levels previously detected.

To solve this, increase the nCL to a clearly detectable level (e.g. 16 dB nCL) to remind the client what to listen for.

Calculated ACT: 1.3 dB nCL



nCL increase 16 dB

Scenario 3: The run exceeds 25 presentations



The run reaches 25 presentations and there is no threshold in sight. There is a higher risk of client fatigue at this point. To solve this, give the client a break, and re-iterate the instructions if needed. You can also perform ACT in a separate appointment, as long as the client's audiogram is present.

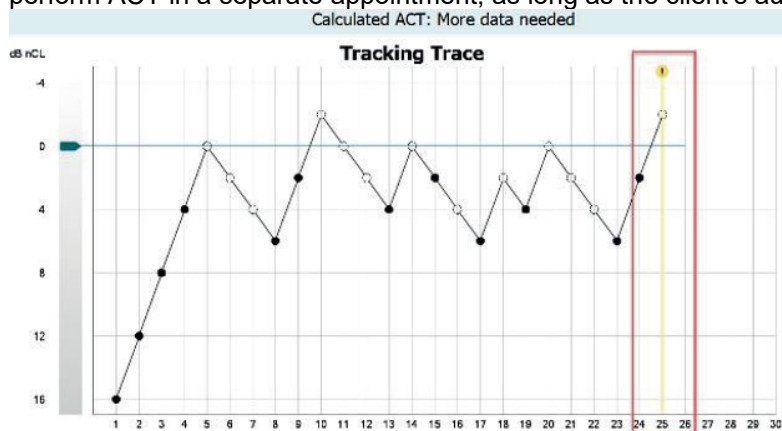

No threshold in sight

Scenario 4: Client responds unexpectedly

An otherwise reliable client responds against your expectation. To solve this, present the stimulus again at the same dB nCL to make sure the first response was not a coincidence.

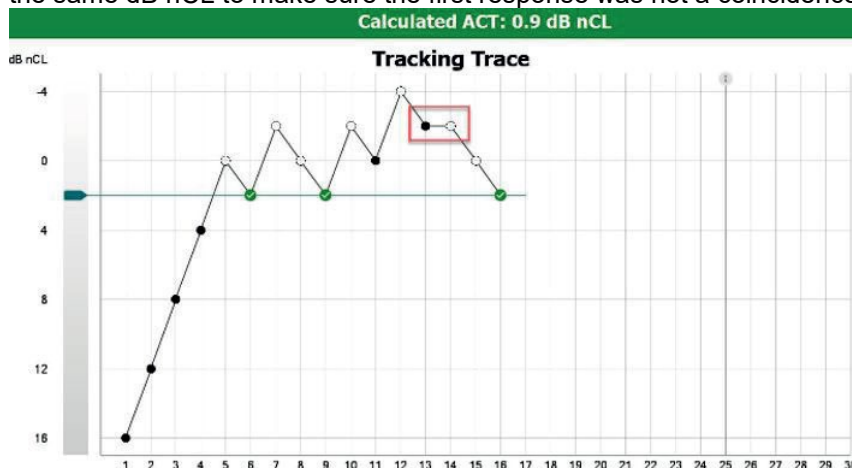

Present stimulus again at same dB nCL

Post-test counselling guidance



To access the post-test counselling guidance, click the 'Guidance' drop box in the middle of the screen. This will reveal the ACT severity categories with accompanying fitting advice.

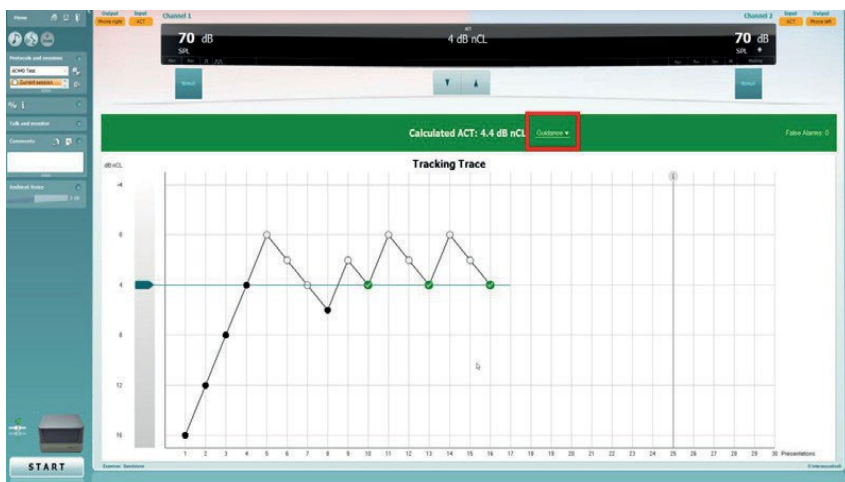

Guidance drop box

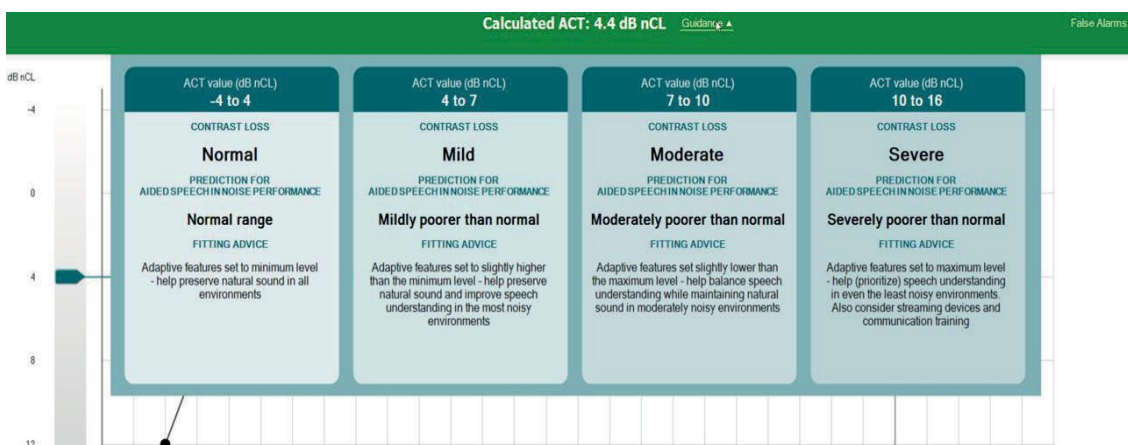

Fitting guidance based on ACT value

Now that you have obtained your ACT value, you can use this in many ways, such as:

- Recommend assistive listening devices
- Set the adaptive features in all hearing aids
- Focus on rehabilitation and communication strategies
- Use selected hearing aids to automatically prescribe adaptive features
- Counsel clients on the prediction of how well they will cope in noisy situations

Automatic hearing aid adaptive feature adjustments using the ACT value

The most effective way to use the ACT value is within the hearing aid fitting software itself. This will automatically optimize the adaptive features of a hearing aid such as noise reduction and directionality. This option is available in selected hearing aid brands only.

Manual adjustments to hearing aid adaptive features using the ACT value

If the hearing aid does not have an option to directly input the ACT value, then you can do adjustments based on the ACT value manually.

Hearing aids usually prescribe adaptive features such as noise reduction and directionality based on the client's audiogram as well as other data put into to the fitting software such as questionnaires and listening preferences.



The ACT value allows for a more objective method of predicting the optimal starting point for these features to activate. Before making manual changes to the hearing device, it is important to understand how adaptive settings are programmed in the device you are fitting.

Further counselling advice

Below is an example script you may want to consider when counselling your client on their ACT value. This advice should be termed appropriately to consider both new and existing users of hearing aids.

"I have now completed the ACT test which tells me about your ability to hear and separate speech from noise in your daily life. Your ACT value today is x, corresponding to within the normal range (or), a mild/moderate/severe contrast loss. A contrast loss means that you need speech and background noise to be separated more to understand what is being said. In other words, you need greater contrast between speech and noise. The higher the value, the more contrast you will need. To help you create this contrast, we need to look at the options available to you to support you in the best way possible. This can be through hearing aid technology level, assistive devices, streaming devices, and communication strategies."



ACT flowchart

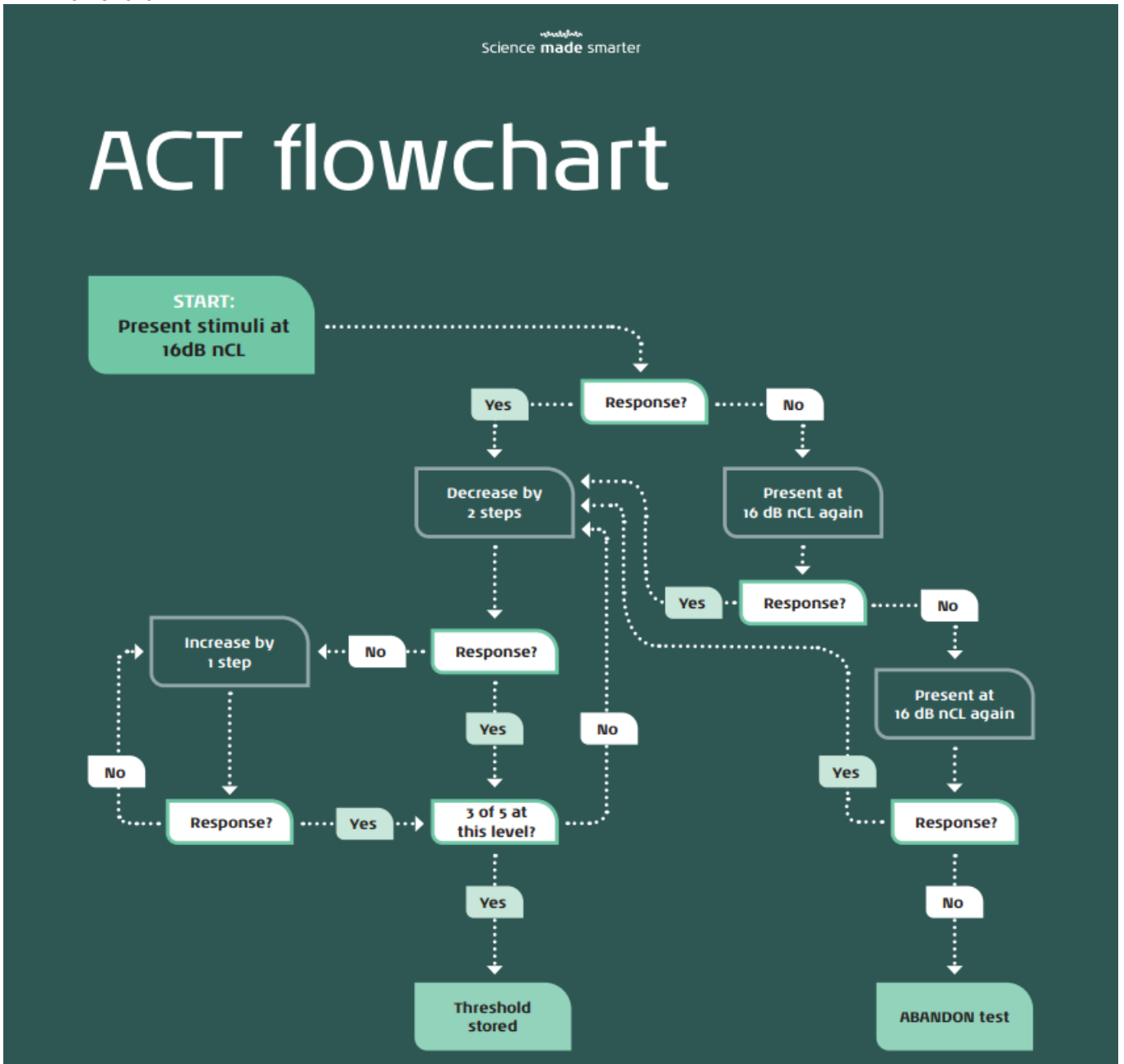



1.7 Working with individual setups (test protocols)

There are many different demands and wishes regarding how an audiometer should both function and appear depending on the specific situation and national standards. One of the greatest advantages of the AC440 module is the flexibility enabling you to tailor the system according to your specific preferences in the so-called “test protocols”. These test protocols are created in the AC440 setup which will be described in this section.

This manual will cover the use of factory/standard test protocols as well as how to create individual test protocols for different purposes or different clinicians working in the same facility.

The following sections describe the setup options for all tests even though you most likely will only need to setup a few. This chapter should be seen as a work of reference where single functions can be looked up rather than a step-by-step guide

1.7.1 Selecting a test protocol:

- 1) Open the AC440 from your patient management system, Noah, OtoAccess® or via stand-alone.
- 2) Go to the AC440 Setup by following **Menu | Setup | AC440 Setup**
- 3) In the **List of protocols**, both factory test protocols with standard/factory test parameters and personalized test protocols can be accessed and selected from the list (e.g., “AC440” and “Joan Jones”).

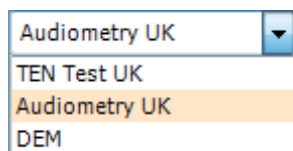

Note: Certain test protocols may be hidden from this test protocol selection using the *Show/Hide protocol* function found under **Menu | Setup | show hide protocols**

About the AC440 setup:

In the AC440 Setup tests will be listed to the left. Unfold each the menu of test to access its options. Each test contains the following options:

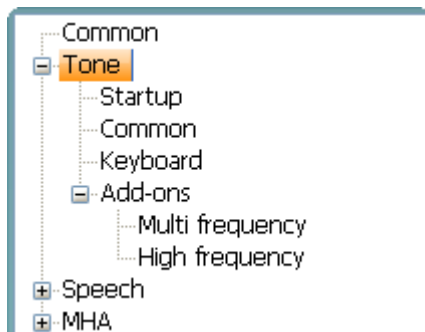

Start-up: These are the settings for which the test will start up

Common: Allows for setting up more general settings of the specific test

Keyboard: Allows for setting up macros for the dedicated Callisto™ audiometry keyboard (if this is used).

Add-ons: Allows for setting up add-on features/subtests if available for a test. These require a special licence.

Note: Some setup screens contain more than one tab offering multiple user controls.

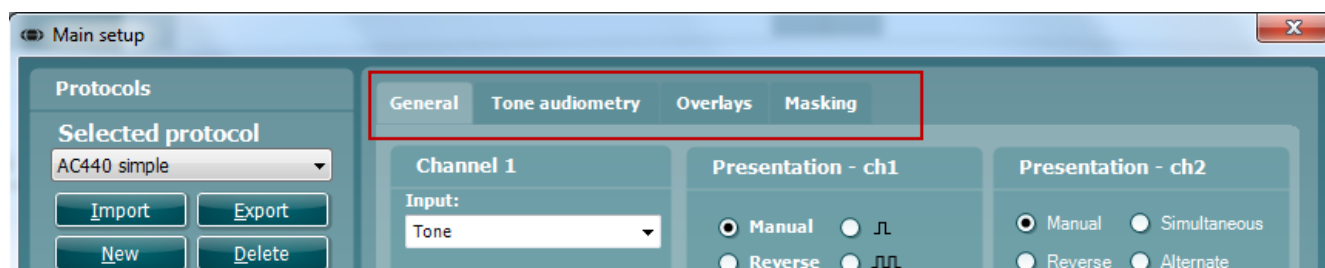



In each setup screen you will find three buttons in the lower right corner:

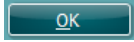

Clicking **OK** will close the AC440 setup and save all changes.



Clicking **Apply** will save changes but without closing the AC440 Setup. The change will, however, immediately be active and visible on the screen behind the setup dialog.



Clicking **Cancel** will close the AC440 setup without saving any changes made.

1.7.2 Creating new protocols

- 1) Click **Menu | Setup | AC440 setup** to enter the Main setup.
- 2) Click **New** to create a new test protocol and fill in the *Name* field (e.g., “Joan Jones”).

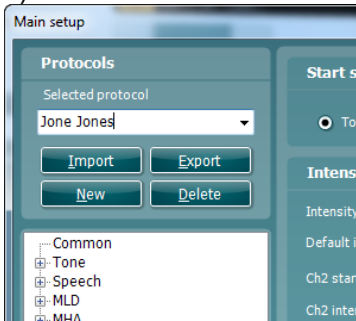

1.7.2.1 Common setup

- 1) The specifics of the test can be selected starting in the *Common* screen shown below:

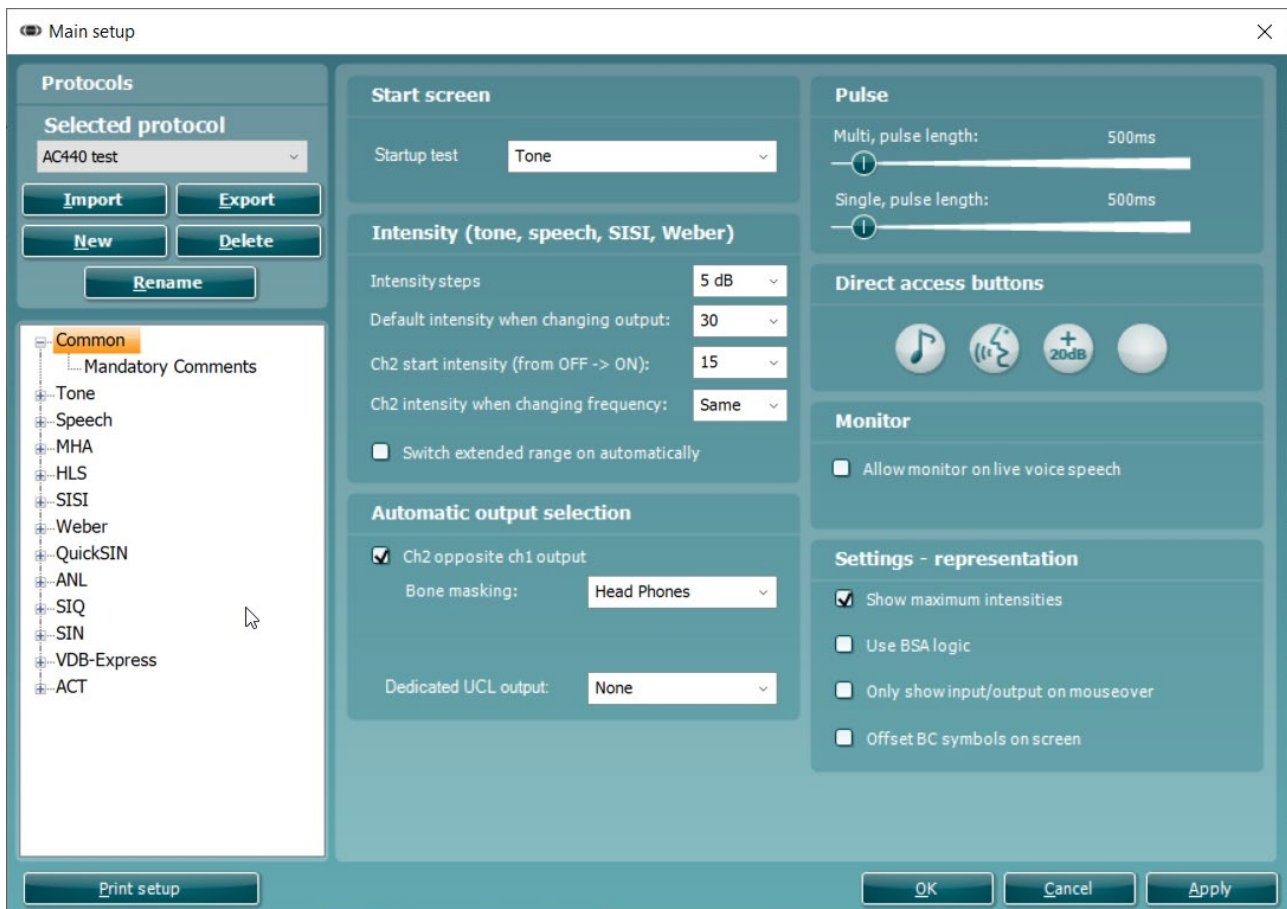

- 2) Choose in which test the system should begin under **Start Screen**. Note that *MLD* is greyed out since it can only be performed after obtaining the hearing thresholds.
Note: Some tests are purchased as additional licences for the AC440. If a license has not been purchased, the test will be greyed out in the start screen selection, and it will not be shown in the 'test tree' of the protocol settings (at number 1 in the above figure).
- 3) Select the default start **Intensity (Tone, Speech, SISI, Weber)**. Use the dropdown lists to select the preferred settings. Checking *Switch extended range on automatically* allows the user to go to high intensities without the need for manual activation of the extended range. The extended range opens automatically as soon as the cursor moves into that area of the audiogram
- 4) In the **Automatic output selection**, the *Ch 2 opposite Ch 1 output* can be ticked. This way channel 2 will automatically choose the opposite output as channel 1 (e.g., if channel 1 is set to *Right*, channel 2 will automatically select *Left*). At *Bone masking*: the user sets which transducer is chosen by default to mask bone measurements. This option will not be active if *Ch 2 opposite Ch 1 output* is not used.
 - Dedicated UCL output will allow the user to select a dedicated UCL transducer output. You can choose between Headphones, Insert Phones and High frequency in the drop down menu.
- 5) Adjust the **Pulse** of the test signal. If *Multi Pulse* or *Single Pulse* are ticked the pulsation length (in mS) can be adjusted using the sliders. Note the option to add multi or single pulse in the front screen (as shown on the graph).
- 6) Direct Access Buttons: right click on the buttons to decide which direct access buttons appear on the main AC440 screen. Up to 4 buttons can be displayed.
- 7) If desired, allow **Monitor** on live voice speech. This function is rarely necessary as it is likely to cause acoustical feedback. However, if the test is performed under circumstances where this is not the case, monitoring of live voice can be allowed by ticking the check box.

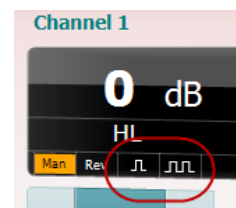



- 8) Under **Settings – representation** tick *Show maximum intensities*. This will allow for showing/not showing the transducer maximum intensities in all tests. This is the dark shaded area on the graph can in the tone audiogram be (de)activated by the dedicated button under *Counselling overlays* 
- 9) *Use BSA logic* forces the audiometry to use symbols according to the standards of the British Society of Audiology (BSA).
- 10) *Only show input/output on mouseover* will hide the not selected input and output options while the mouse is not over it and results thereby in a calmer screen.



- 11) *Offset BC symbols on screen* allows for the BC icons to be offset from the central lines indicating their frequency – this is purely to allow simpler identification of ear side BC values when they are displayed as a single Audiogram.

If you expand the Common settings, you will have the option to amend settings for Mandatory Comments.

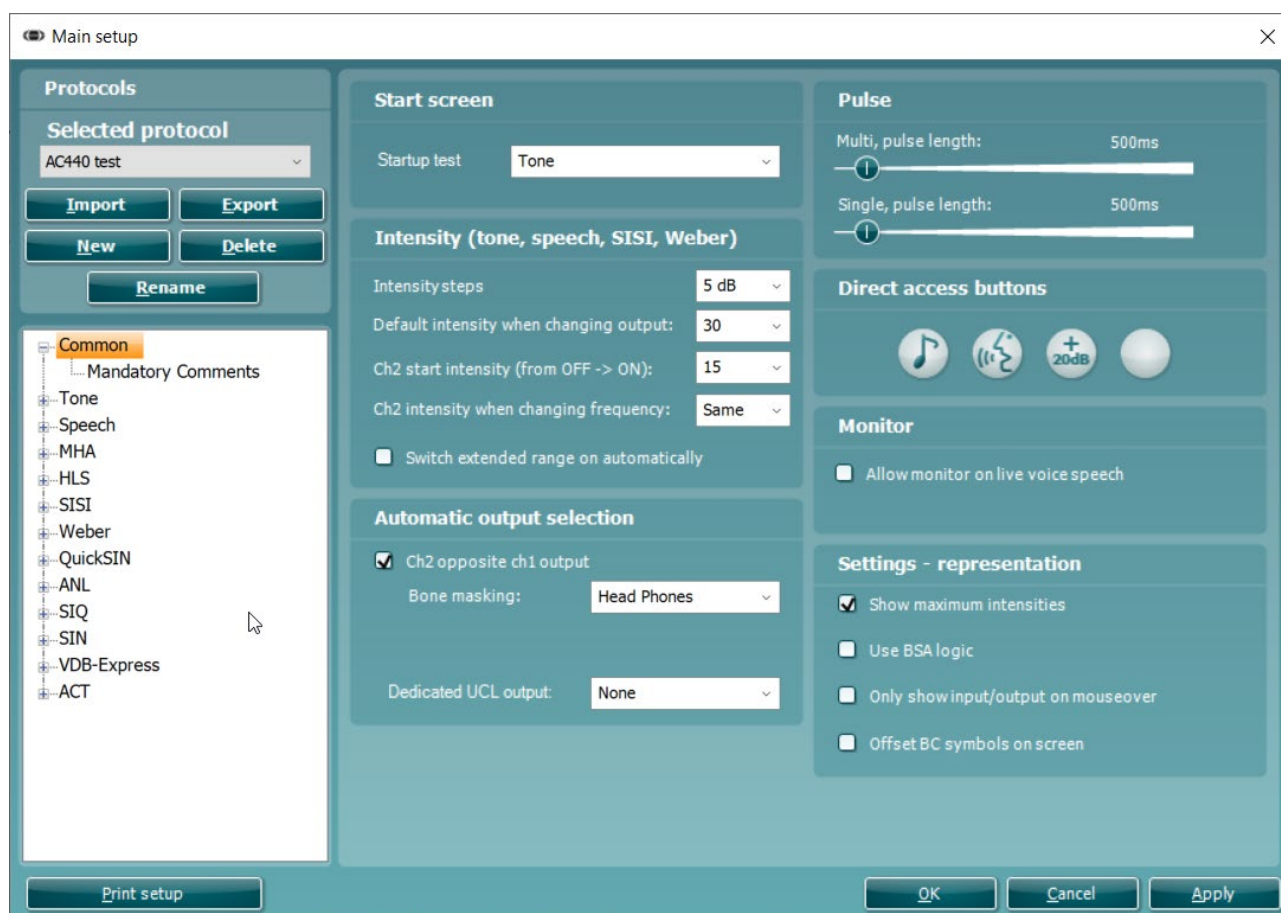

Mandatory Comments allow you to enable a setting which forces the user to comment on the test session when saving the session. This is to ensure relevant session comments are provoked to be stored alongside the session data.



Main setup [Close]

Protocols

Selected protocol: AC440 [v]

[Import] [Export]

[New] [Delete]

[Rename]

- Common
 - Mandatory Comments
 - Tone
 - Speech
 - MHA
 - HLS
 - SISI
 - Weber
 - QuickSIN
 - ANL
 - SIQ
 - SIN

Mandatory Comments Settings

Make Comments for AUD sessions mandatory

[Print setup] [OK] [Cancel] [Apply]



1.7.2.2 Tone testing setup

Start-up

1) To enter the *Start-up* options for tone testing unfold the **Tone** options and click *Start-up*.

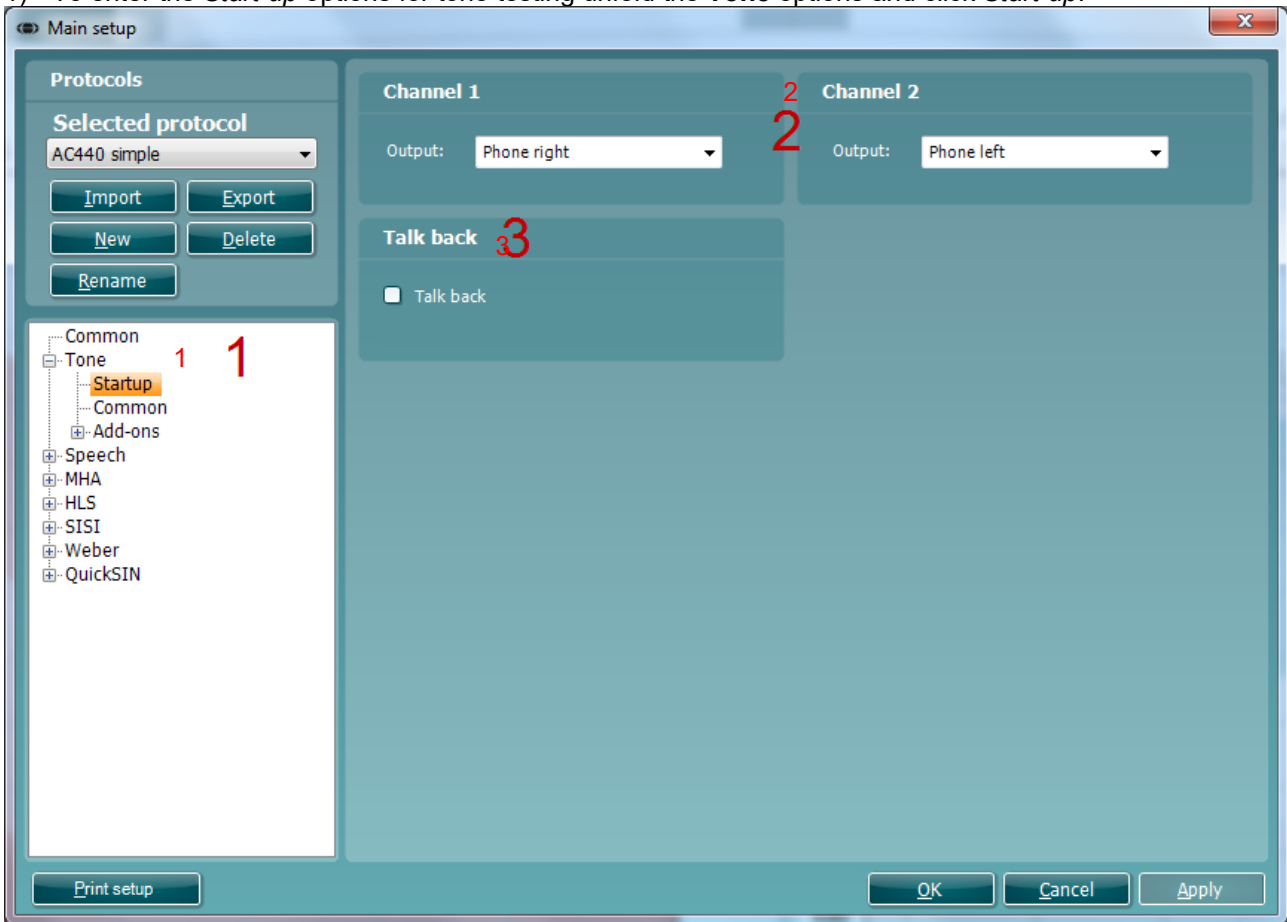

- 2) Default *Output* of **Channel 1** and **Channel 2** can be selected in the two dropdown lists. The selection will differ depending on which transducers are calibrated.
- 3) The **Talk back** can be activated by ticking the check box.

Common:



- 4) To enter the *Common* options for tone testing unfold the **Tone** options and click *Common*. Here you can adjust some of the more frequent tone audiometry settings starting with the **General** settings.

The screenshot displays the software's configuration window for tone audiometry. On the left, a 'Protocols' sidebar shows 'Selected protocol' as 'Costco Protocol' with buttons for 'Import', 'Export', 'New', 'Delete', and 'Rename'. Below this is a tree view where 'Common' is selected under the 'Tone' category. The main window has four tabs: 'General', 'Tone audiometry', 'Overlays', and 'Masking'. The 'General' tab is active, showing settings for 'Channel 1' (Input: Tone) and 'Channel 2' (Input: NB). The 'Monitor' section has 'Ch1' checked and a volume slider at 70. The 'Settings - controls' section includes 'Jump strategy' (Butterfly selected), 'Intensity decrease when changing frequency' (Off), and 'Warble freq.' (5Hz). The 'Masking' tab is also visible, showing 'Threshold intensity' selected and 'Show masking information on screen' checked.

The screenshot displays the software's configuration window for tone audiometry, specifically the 'Masking' tab. The 'Selected protocol' is 'Costco Protocol'. The 'Tone' menu is expanded to 'Common'. The 'Masking' tab is active, showing settings for 'Show masking information on screen' (checked), 'Show masking cursor' (checked), and 'Show ch1 and ch2 in a single audiogram' (unchecked). The 'Settings - representation' section includes 'Masking' options (AC, BC, FF, IP) and 'Show masking cursor' (checked). The 'Settings - controls' section includes 'Jump to 1KHz by output change' (checked), 'Set ch2 to manual at store' (checked), and 'Mouse controlled audiometry' (unchecked). The 'Warble freq.' is set to 5Hz.

Note: This screen contains four tabs (*General, Tone audiometry, Overlays, Masking*).



- 5) Default input for **Channel 1** and **Channel 2** can be set using the dropdown lists. Select between *Tone*, *Warble tone*, *NB* (**N**arrow **B**and noise), and *WN* (**W**hite **N**oise) for both channels. In addition, *TEN Noise* can be selected for channel 2 (if purchased). See more information about the TEN test in Appendix 3.
Channel 1 and **Channel 2 Presentation**: You have the option to tick *Manual* so that the stimulus is only presented when manually activated. Ticking **Reverse** will cause the signal to be presented continuously, only disappearing when the stimulus is activated.
Single Pulse and **Multi Pulse** presentation for channel 1. The duration of the stimulus can be adjusted in the common options described above. Furthermore, you may wish to have presentation in both channels and tick **Simultaneous** which will lock channel 1 and channel 2 together or have the presentation in the two channels alternating to each other and tick **Alternate**.
- 6) Under **Monitor** one or both channels may be ticked if monitoring is preferred. The level of the monitoring can be set using the slider.
- 7) In **Other settings** you can tick *Aided* if audiograms usually are obtained with hearing aids and/or *Binaural* if both ears are tested at the same time. Both aided and binaural measures are stored as separate curves. *HL* (**H**earing **L**evel), *MCL* (**M**ost **C**omfortable **L**evel) or *UCL* (**U**ncomfortable **L**evels) may also be ticked depending on your preference. These are also stored as separate curves.
- 8) **Settings –**
- Ignore mouse over touch switch* which will make AC440 ignore the cursor touching the stimuli area in the front screen. Instead, you will need to present the stimulus manually using the PC keyboard or the dedicated audiometer keyboard.
 - When ticking *Jump to 1 kHz by output change* the cursor will jump back to test 1 kHz upon output changes.
- 9) The *Jump strategy* contains three different options:
- | | |
|------------------|---|
| <i>Butterfly</i> | The cursor will start at 1kHz and move upwards in frequency as the thresholds are stored. After testing the high frequencies, the cursor will move back to re-test 1kHz and move downwards. When jumping back to 1kHz the Butterfly strategy can be set to start the re-test at either the default start intensity or the intensity of the first threshold. |
| <i>Bottom up</i> | The cursor will start at 1kHz and move upwards. When the high frequencies are tested, the cursor will jump to the lowest test frequency and move upwards towards 1kHz. |
| <i>None</i> | Frequencies are changed manually using the arrow buttons in the main screen, the PC keyboard, or the dedicated keyboard. |
- 10) For *Intensity decrease when changing frequency*, choose the level to decrease to when changing the test frequency, using the drop-down menu. .
- 11) By activating *Set ch2 to manual after store*, you assure that masking is automatically switched off when storing a point and jumping to the next frequency.
- 12) Ticking mouse controlled audiometry will allow audiometry to be performed using the mouse.
- 13) If testing with warble, tones the frequency of the warble tones can be adjusted in the *Warble Frequency* slider. This may for example be helpful if testing patients with tinnitus.
- 14) Under **Masking** in **Settings – representation**: Tick *Show masking information on screen* if you want the masking intensity for every threshold to be visible on screen. You may choose to see the masking information for air conduction (*AC*), bone conduction (*BC*), free field (*FF*) and insert phones (*IP*).
- If ticking *Show masking cursor*, a cursor indicating the masking level will be visible on channel 2.

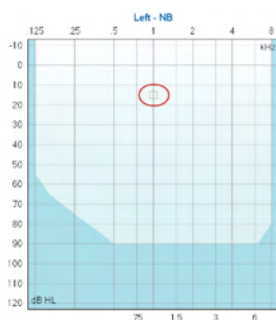

- 15) Tick *Show Ch1 and Ch2 in a single audiogram* to show a single audiogram by default
- 16) Choose *Swap intensity keys on PC keyboard* and *Swap arrows on intensity buttons* to change the direction when adjusting intensity and frequency.
- 17) *Hide unmasked threshold where masked exist* will only display the masked (i.e., real) thresholds by default. This option can also be selected by right mouse click on the audiogram.

Protocols

Selected protocol: Ambient noise, Continuous noise

Buttons: Import, Export, New, Delete, Rename

Tone audiometry

HL / MCL

<input checked="" type="checkbox"/>	125	<input checked="" type="checkbox"/>	3000	<input checked="" type="checkbox"/>	11200
<input checked="" type="checkbox"/>	250	<input checked="" type="checkbox"/>	4000	<input checked="" type="checkbox"/>	14000
<input checked="" type="checkbox"/>	500	<input checked="" type="checkbox"/>	6000	<input checked="" type="checkbox"/>	16000
<input checked="" type="checkbox"/>	750	<input checked="" type="checkbox"/>	8000	<input checked="" type="checkbox"/>	18000
<input checked="" type="checkbox"/>	1500	<input checked="" type="checkbox"/>	9000	<input checked="" type="checkbox"/>	20000
<input checked="" type="checkbox"/>	2000	<input checked="" type="checkbox"/>	10000		

Buttons: Check all, Uncheck all

UCL

<input checked="" type="checkbox"/>	125	<input checked="" type="checkbox"/>	3000	<input checked="" type="checkbox"/>	11200
<input checked="" type="checkbox"/>	250	<input checked="" type="checkbox"/>	4000	<input checked="" type="checkbox"/>	14000
<input checked="" type="checkbox"/>	500	<input checked="" type="checkbox"/>	6000	<input checked="" type="checkbox"/>	16000
<input checked="" type="checkbox"/>	750	<input checked="" type="checkbox"/>	8000	<input checked="" type="checkbox"/>	18000
<input checked="" type="checkbox"/>	1500	<input checked="" type="checkbox"/>	9000	<input checked="" type="checkbox"/>	20000
<input checked="" type="checkbox"/>	2000	<input checked="" type="checkbox"/>	10000		

Buttons: Check all, Uncheck all

Hide unselected HL, MCL and UCL frequencies

Hearing loss index on audiogram

Show european CPT-AMA index Show Røser

Show AC PTA index

125	Weight	0	1K	Weight	1	4K	Weight	1
250	Weight	0	1500	Weight	0	6K	Weight	0
500	Weight	1	2K	Weight	1	8K	Weight	0
750	Weight	0	3K	Weight	0			

Add 0 to the AC PTA when in the speech screen.

Buttons: Print setup, OK, Cancel, Apply

- 18) Under the **Tone audiometry** tab, you can select the desired test frequencies for **HL/MCL** and **UCL** by ticking the preferred frequencies. Use the *Check all* or *Uncheck all* buttons to help if needed. If the unselected frequencies are not to be visible on the graph, then also tick *Hide unselected HL, MCL and UCL frequencies*. This way only the selected frequencies will appear on the audiogram.

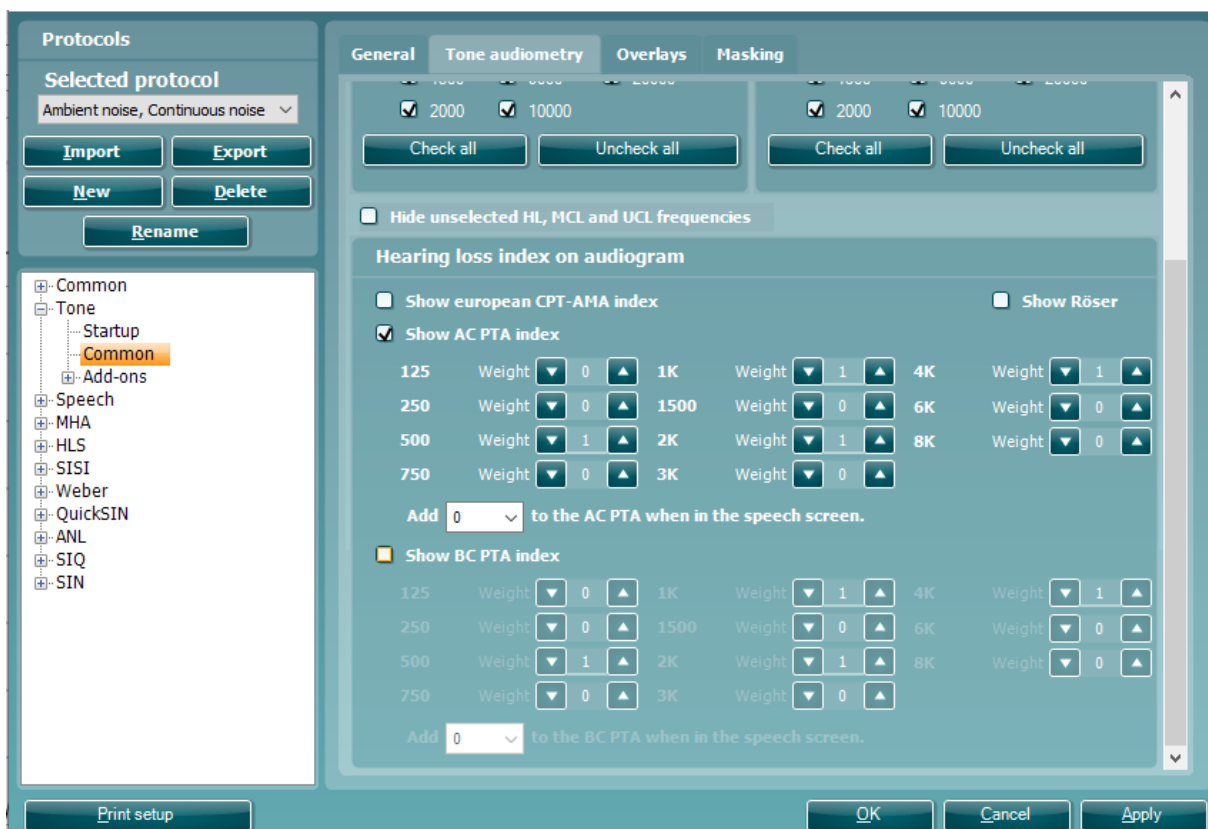

- 19) The **Hearing loss index on audiogram** allows for ticking *Show European CPT-AMA index*, *Show AC PTA index* or *Show BC PTA index*. The European CPT-AMA is calculated using the values from the table below which ensures that the different frequencies are weighted to display a correct quantification of impairment due to the hearing loss. The dropdown menu below these settings for PTA index indicate the number of additional decibels you wish to add to the threshold when entering speech for the initial stimulus level.



HV* (dB)	500 Hz	1000 Hz	2000 Hz	4000 Hz
10	0.2	0.3	0.4	0.1
15	0.5	0.9	1.3	0.3
20	1.1	2.1	2.9	0.9
25	1.8	3.6	4.9	1.7
30	2.6	5.4	7.3	2.7
35	3.7	7.7	9.8	3.8
40	4.9	10.2	12.9	5.0
45	6.3	13.0	17.3	6.4
50	7.9	15.7	22.4	8.0
55	9.6	19.0	25.7	9.7
60	11.3	21.5	28.0	11.2
65	12.8	23.5	30.2	12.5
70	13.8	25.5	32.2	13.5
75	14.6	27.2	34.0	14.2
80	14.8	28.8	35.8	14.6
85	14.9	29.8	37.5	14.8
90	15.0	29.9	39.2	14.9
95	15.0	30.0	40.0	15.0
100	15.0	30.0	40.0	15.0

If selecting the PTA index, you can choose the frequencies that should be included in the calculation. The default setting will be 500, 1000, 2000, and 4000 Hz (Fletcher index). In this calculation method all frequencies are equally weighted and averaged to give the figure.

A further example of the Fletcher index is as follows:

$$\frac{500\text{Hz Threshold} + 1\text{kHz Threshold} + 2\text{kHz Threshold} + 4\text{kHz Threshold}}{4} = \text{PTA Score}$$

Should one of the frequencies have a double emphasis then the following calculation will be applied.

$$\frac{500\text{Hz Threshold} + (2 \times 1\text{kHz Threshold}) + 2\text{kHz Threshold} + 4\text{kHz Threshold}}{5} = \text{PTA Score}$$

The PTA index calculation is used to give an average hearing level value to allow categorisation of the patients hearing loss shown on the audiogram. This score is used in certain markets to determine whether hearing rehabilitation should be reimbursed by their government/public funding or not (should it reach a certain threshold/value). This calculation can be configured as there are different frequency emphasis in certain languages/market, for example some countries have their own calculation which includes a double emphasis of 1kHz.

In addition to an AC PTA index, you can also calculate a BC PTA index. The settings in this screen are an exact replication of the settings and application used in the AC PTA index, but the calculation will now be made for BC thresholds.

The PTA index also provides the option to add a certain level to the result using the dropdown list. This is useful since the PTA is often used to determine the start intensity for speech testing. If you prefer to start the speech test at for example 15 dB above PTA this can be selected in the dropdown list:

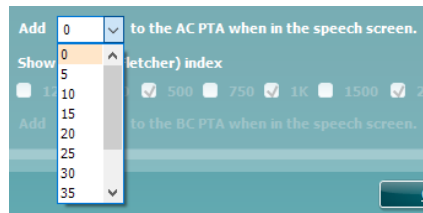

Note: The PTA is calculated for insert phones and headset. However, if values for both are stored no PTA value is calculated.

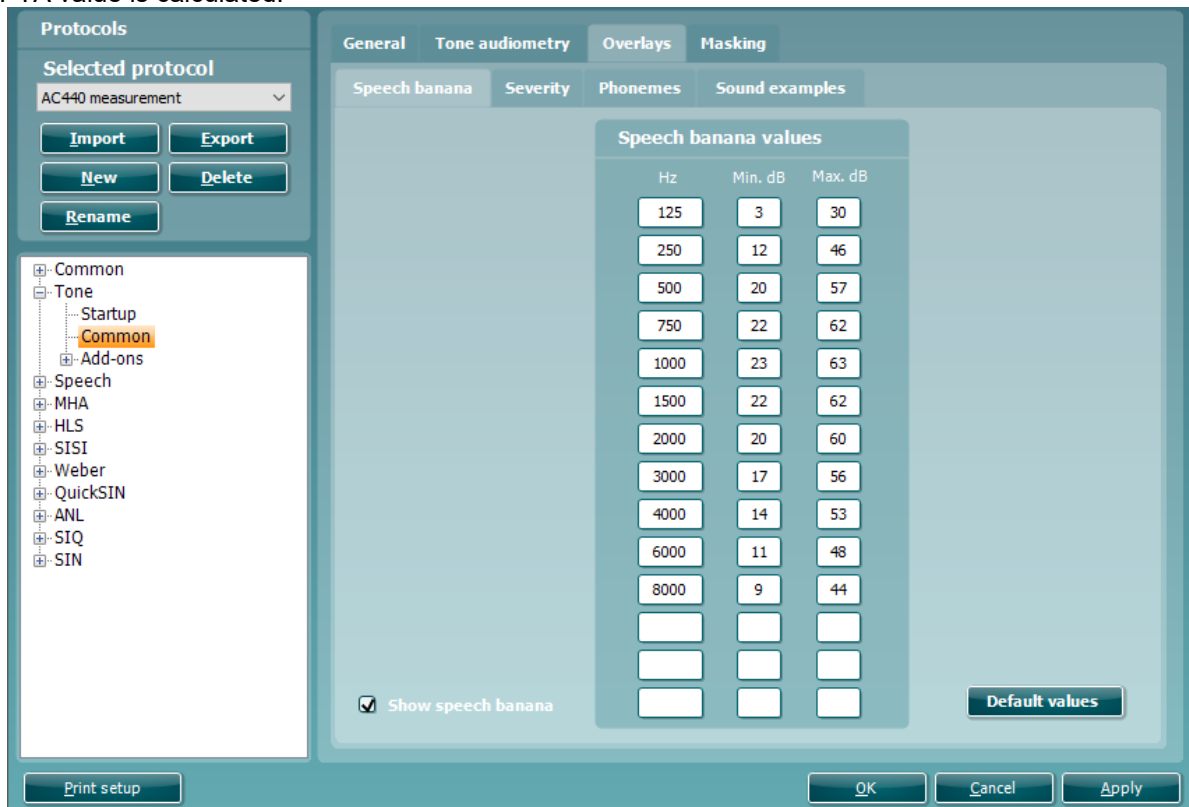

- 20) Since the speech banana is language dependent the AC440 allows for entering individual speech banana values. Enter your values for the upper and lower margin of the speech banana under **Top part of banana** and **Bottom part of banana**.
- 21) For counselling purposes, you can tick *Show speech banana* in the **Speech Banana** tab. This allows for a speech banana view in shading in the audiogram screen. In the tone audiometry test screen, the dedicated button under *Counselling overlays*, , also allows for (de)activating the speech banana.

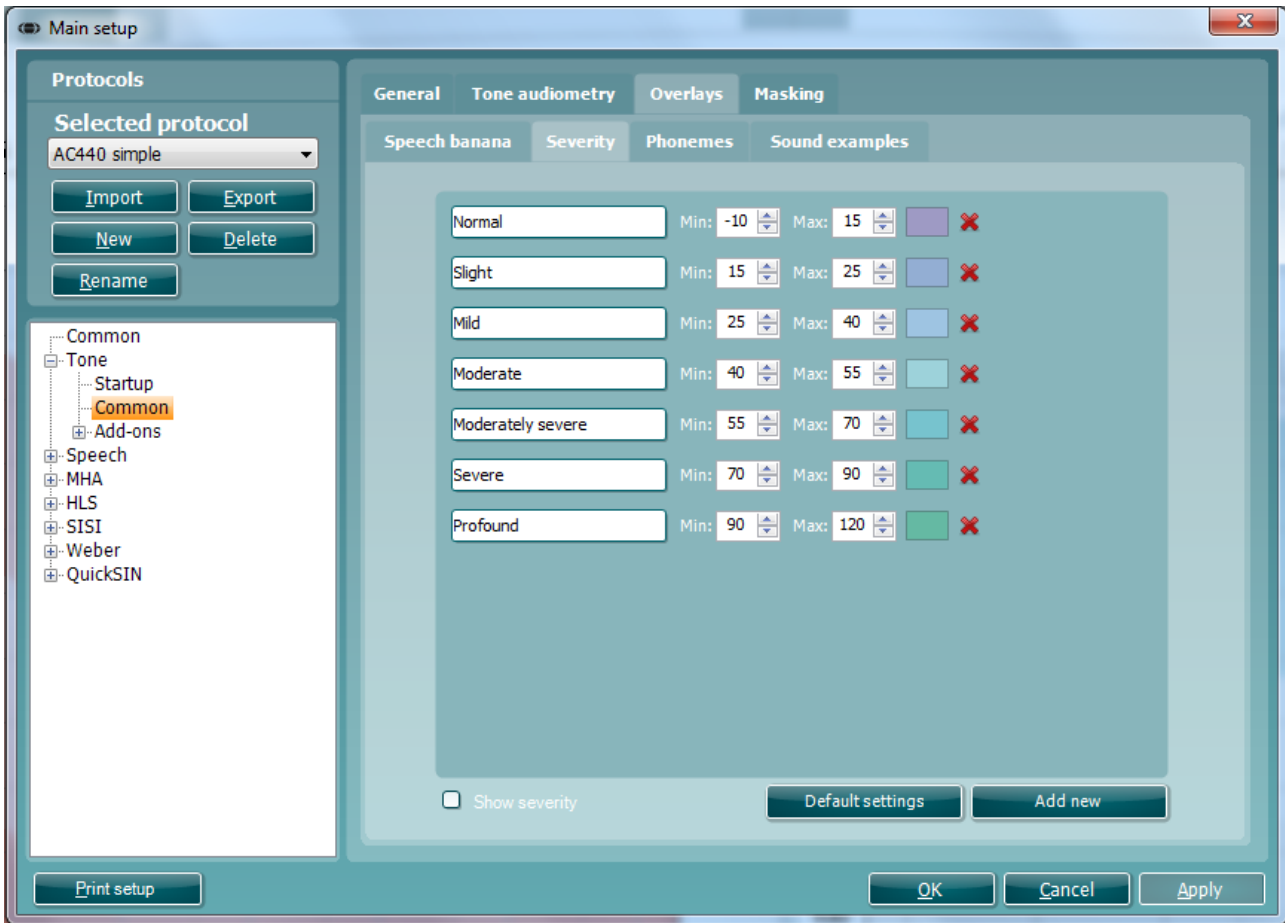

- 22) A **Severity** indication can be set up by defining the label, minimum and maximum dB, and color for each indication in the audiogram.
- 23) For counselling purposes, you can tick *Show severity* in the **Severity** tab. This allows for severity indications in the audiogram screen. In the tone audiometry test screen, the dedicated button under *Counselling overlays*, , also allows for (de)activating the severity indications.

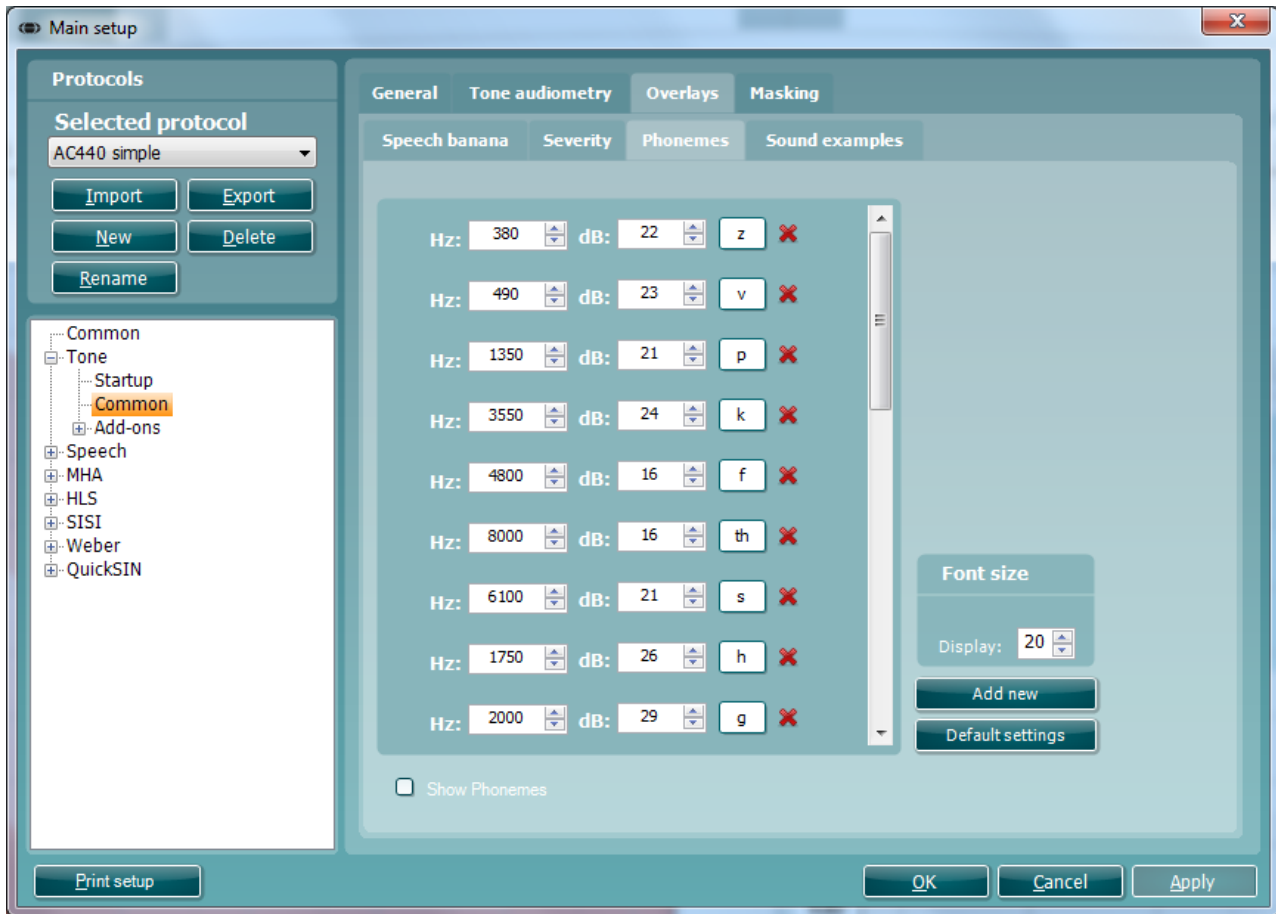

- 24) The **Phonemes** to be shown in an audiogram can be set up by defining the labels and positions of all phonemes. Indicate the font size as how they must appear on screen.
- 25) For counselling purposes, you can tick *Show phonemes* in the **Phonemes** tab. This allows for phonemes in the audiogram screen. In the tone audiometry test screen, the dedicated button under *Counselling overlays*, , also allows (de)activating the phonemes.

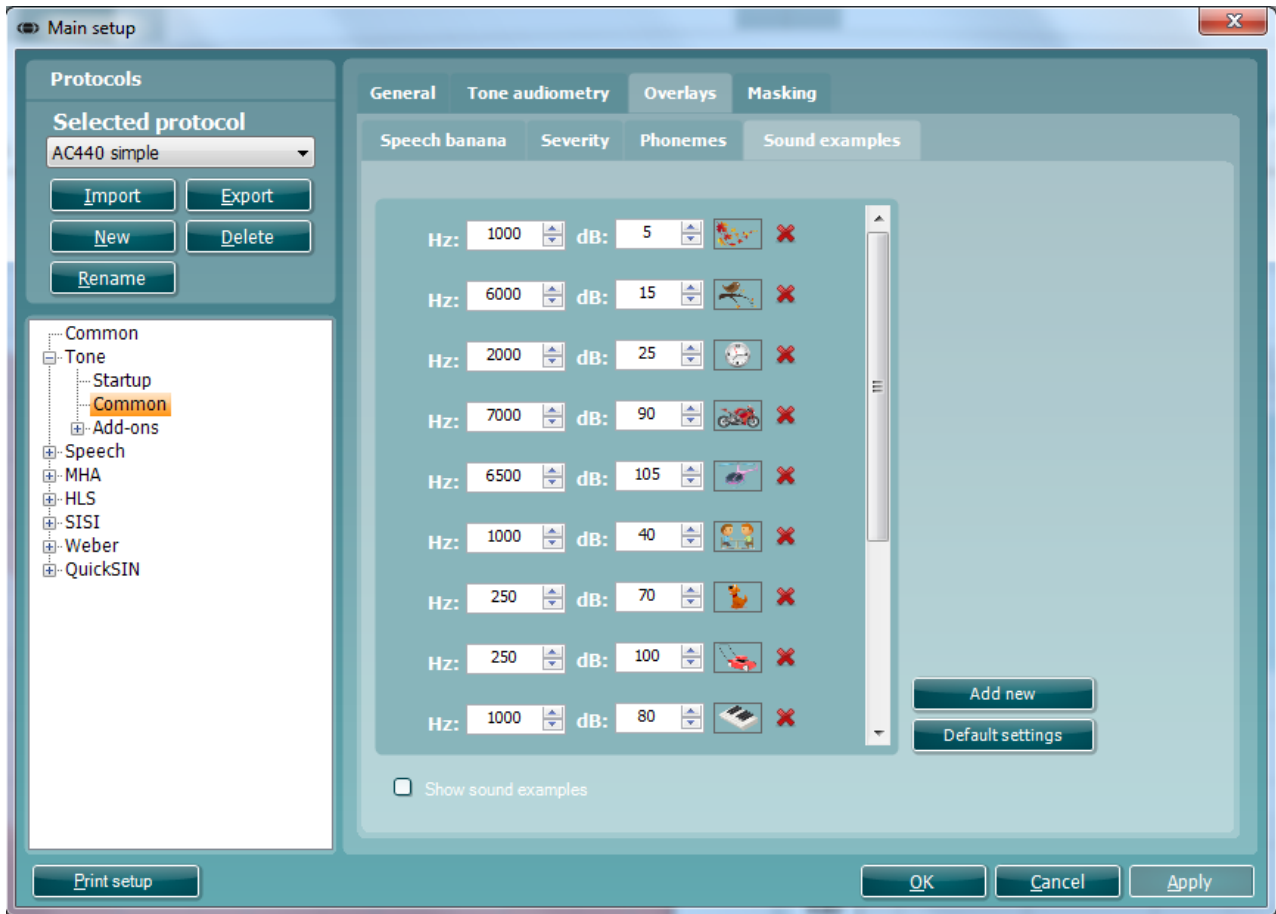

- 26) The **Sound examples** to be shown in an audiogram can be set up by defining the positions of all examples. When adding a new picture, you are asked to point out where the picture can be found. Note that the file type must be *.png to allow transparent background colors.
- 27) For counselling purposes, you can tick *Show sound examples* in the **Sound examples** tab. This allows for sound examples in the audiogram screen. In the tone audiometry test screen, the dedicated button under *Counselling overlays*, , also allows (de)activating the sound examples.

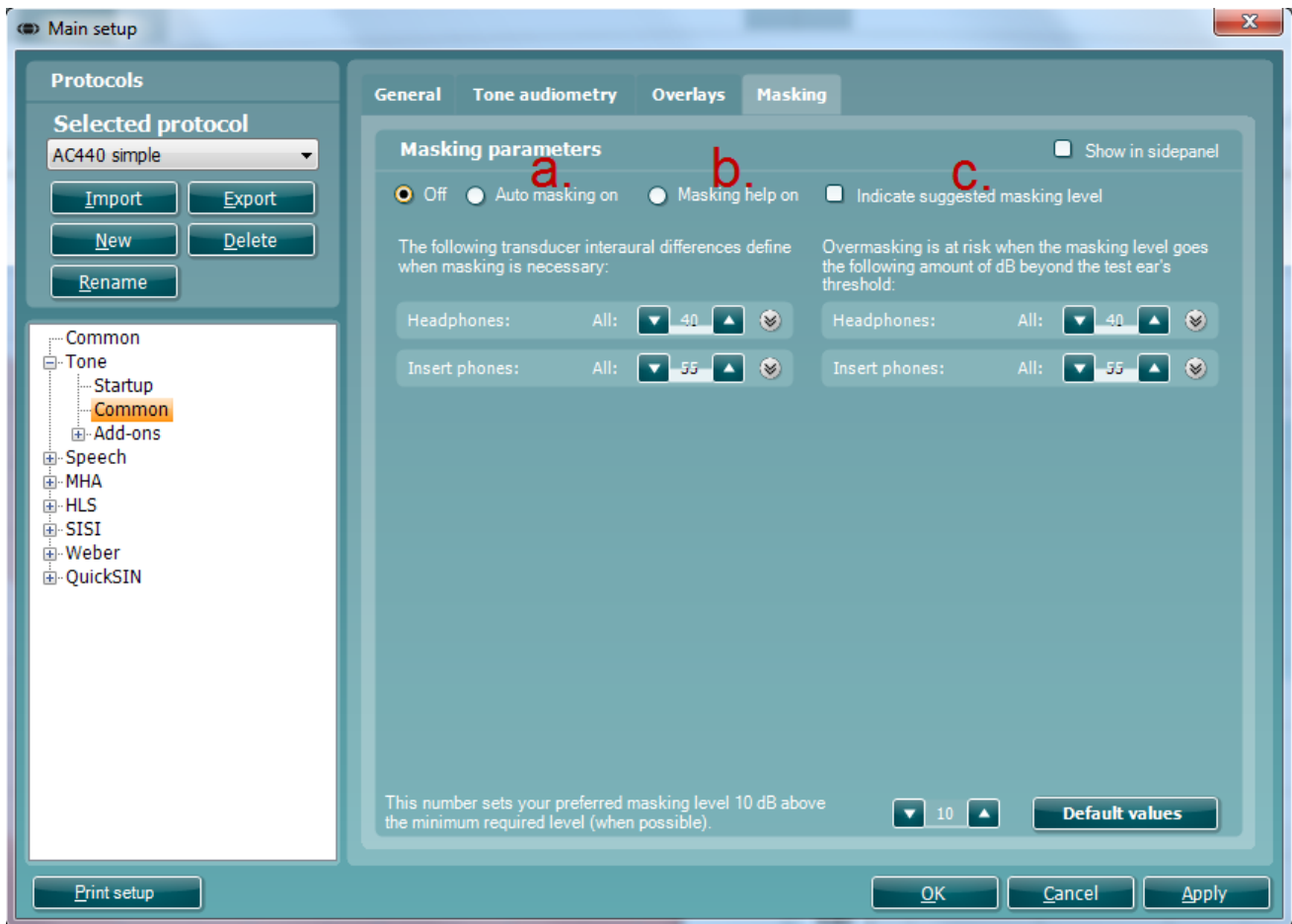

- 28) **Masking Tab:** In this section, the tester can decide if Automasking or Masking Help should be turned on. The user can also change the interaural differences as well as the default values for over masking.
- a. Auto masking on: masking will start automatically where required
 - b. Masking Help on: a light in channel 2 will indicate if masking is required and whether there is undermasking or overmasking occurring
 - c. Indicate suggested masking level: will suggest the masking level that should be used

In this section the user can configure their Automasking feature by adjusting the interaural difference levels depending on the transducer selected. They can also adjust the level at which the transducer will be overmasking.

For more details, please refer to the Automasking and Masking Help Quick Guide in Appendix 4

Add-ons:

- 29) To enter the *Add-on* options for tone testing unfold the **Tone** options and click the plus in front of *Add-on*. Then select *Multi Frequency*.
- 30) Here settings for *Multi Frequency* can be adapted. Adjust the frequency *Resolution* using the dropdown list.

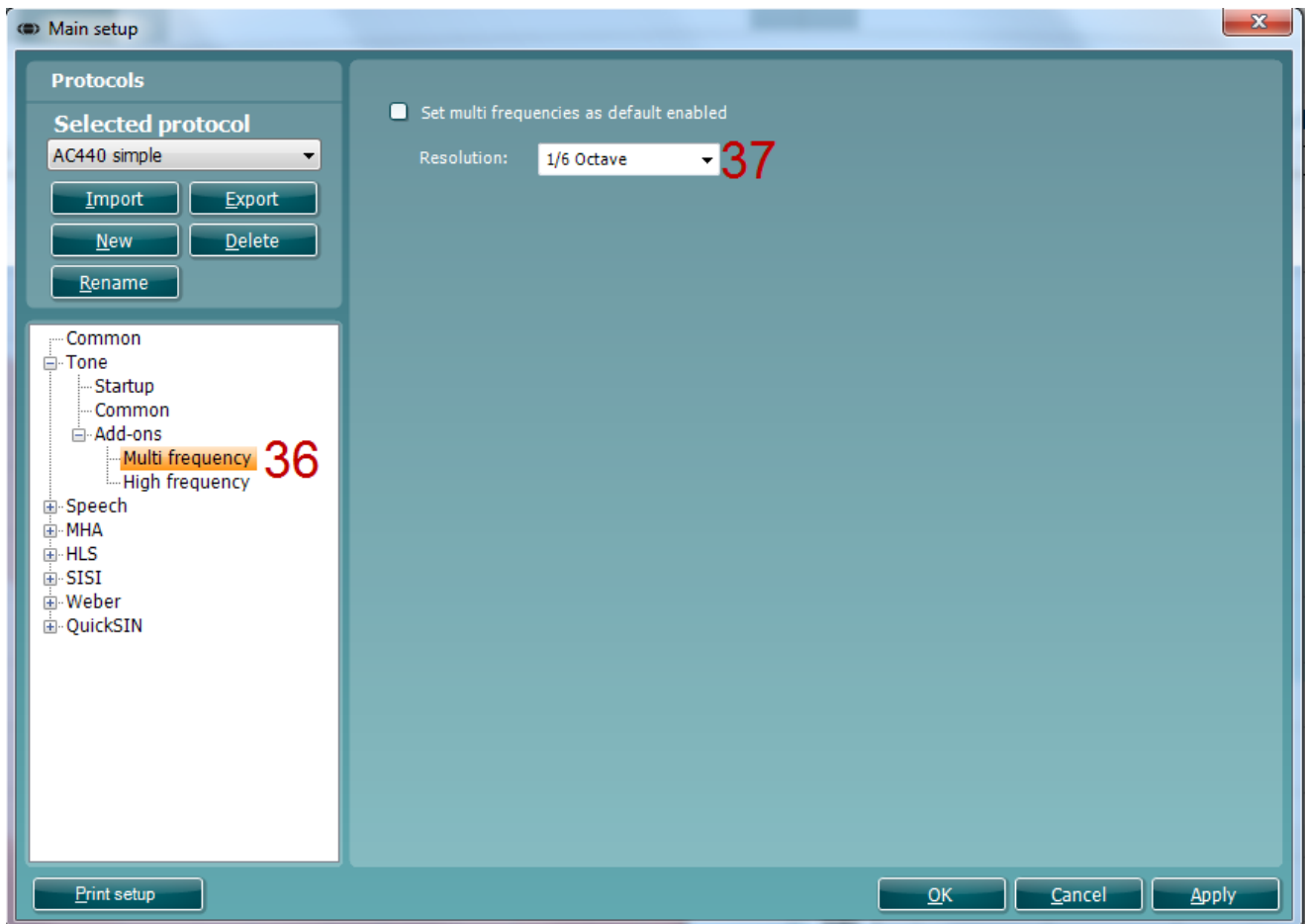

Tick *Set multi frequencies as default enabled* to set the function to be default as on (for further description of multi frequency testing please see section 1.6.2)

Note: *High frequency* Add on tab is currently not in use (for further description of high frequency testing please see section 1.6.1).



1.7.2.3 Speech testing setup

Start-up

1) To enter the *Start-up* options for speech testing, unfold the **Speech** options and click *Start-up*.

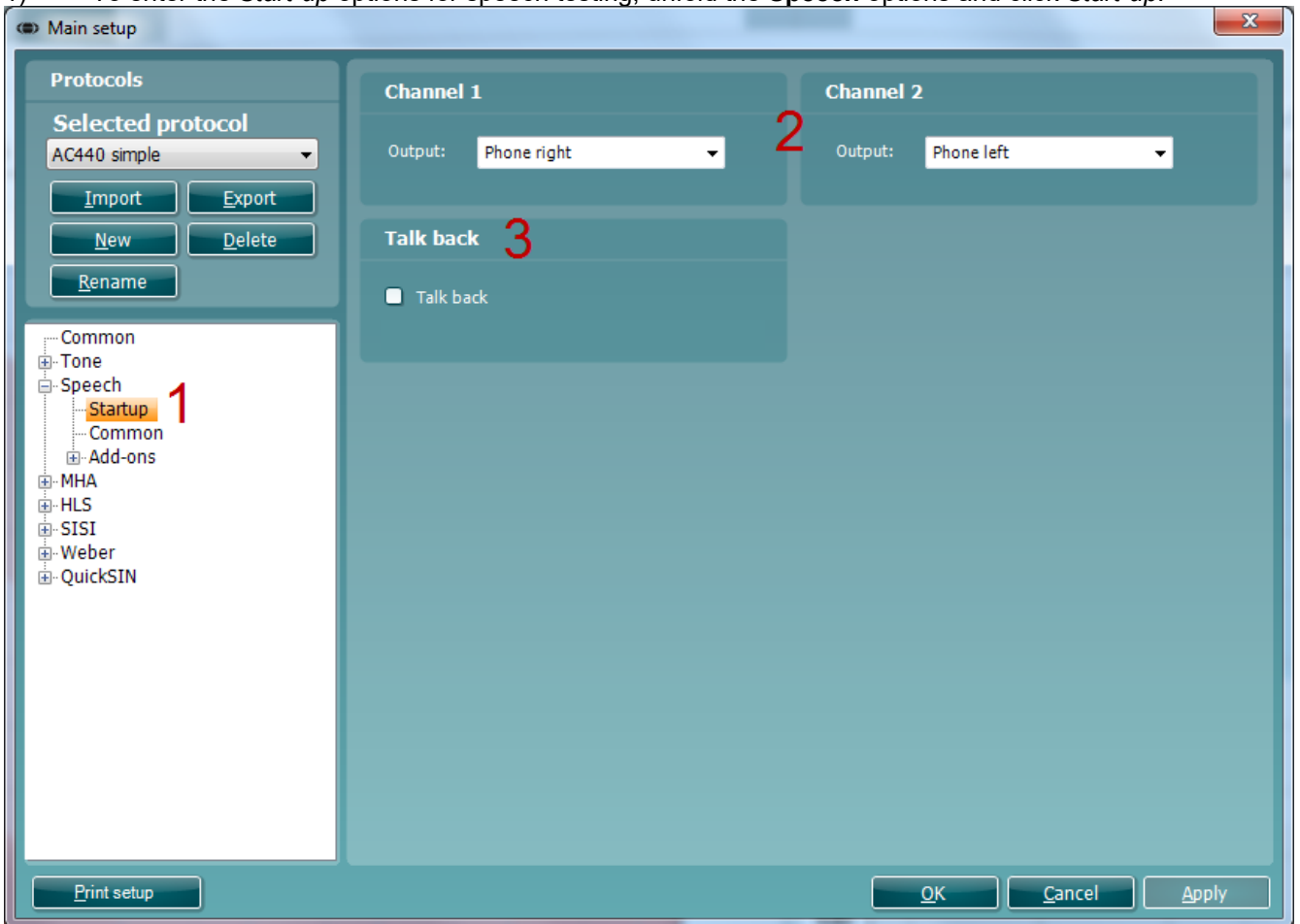

- 2) Select the default output of **Channel 1** and **Channel 2** in the two dropdown lists. The selection will differ depending on which transducers are calibrated.
- 3) Activate the **Talk back** by **ticking the check box**.Common
- 4) To enter the *Common* options for speech testing unfold the **Speech** options and click *Common*.

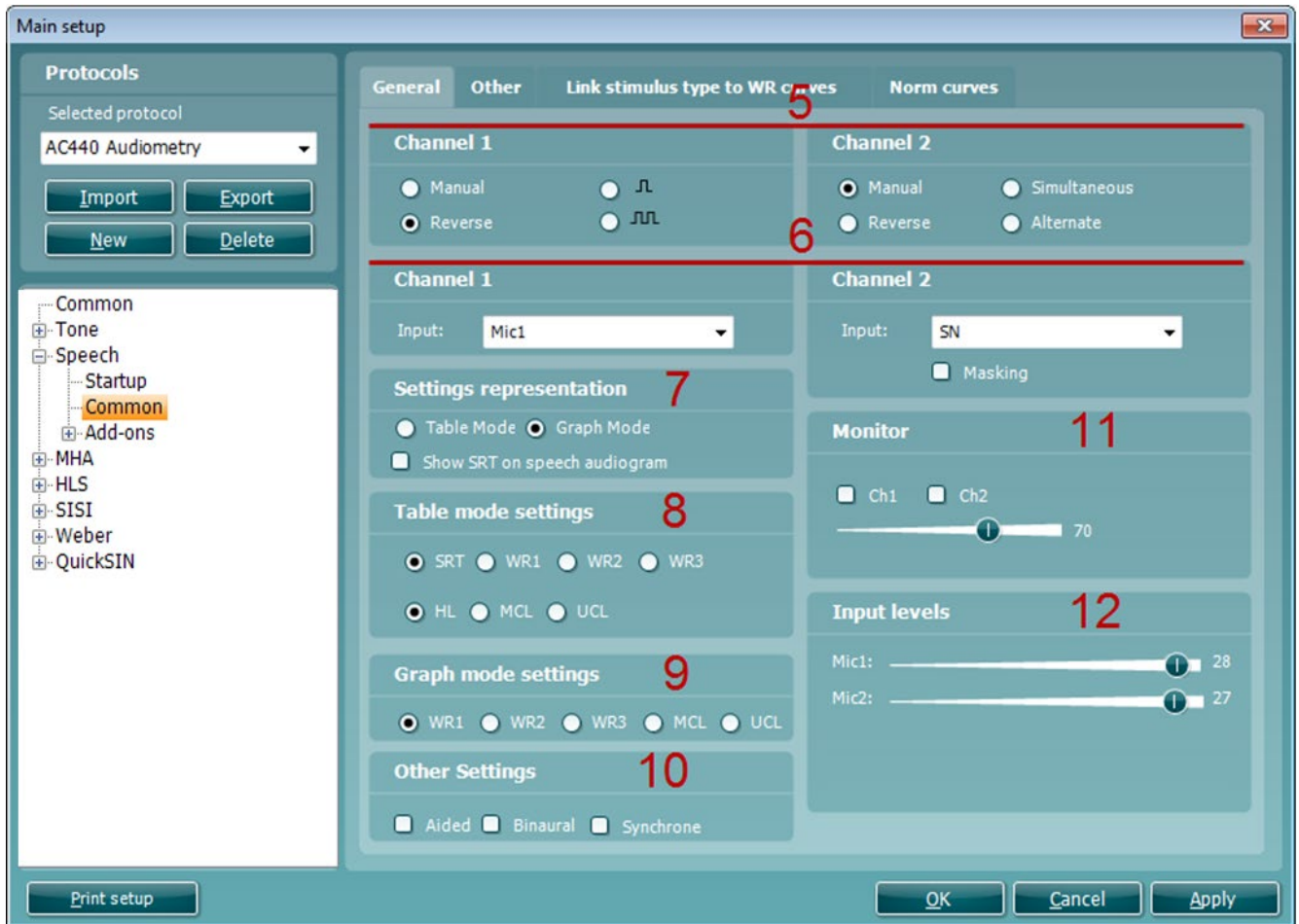

Note: This screen contains four tabs (*General*, *Other*, *Link stimulus type to WR curves*, and *Norm curves*).

- 5) Set the **Channel 1** and **Channel 2**. You have the option to tick *Manual* so that the stimulus is only presented when manually activated. Ticking *Reverse* will cause the signal to be presented continuously, only disappearing when the stimulus is activated. You also have the option to select between *Single Pulse* and *Multi Pulse* presentation for channel 1. The duration of the stimulus can be adjusted in the common options described above. Furthermore, you may wish to have presentation in both channels and tick *Simultaneous* which will lock channel 1 and channel 2 together or have the presentation in the two channels alternating to each other and tick *Alternate*
- 6) The default input for **Channel 1** and **Channel 2** can be setup using the dropdown lists. Select between *Mic1*, *SN* (Speech Noise) and *Wave file1 or 2* as input for channel 1, and *Mic1*, *WN* (White Noise), *SN* (Speech Noise) and *Wave file1 or 2* as input for channel 2¹³.

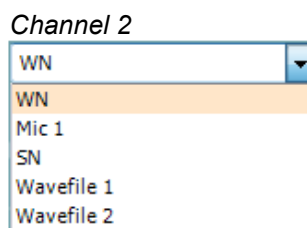
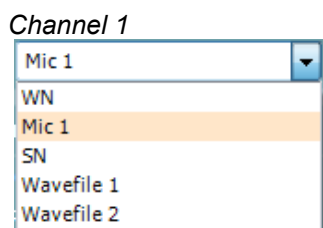

- 7) In **Settings – representation** you can choose between *Table Mode* and *Graph Mode*.
- **Graph Mode:** If selecting Graph Mode, the results are displayed in a graph. *Show SRT on speech audiogram* calculates the SRT value based on the norm curve (the distance in dB from the point where the norm curve crosses 50% to the point where the speech curve crosses 50%) like shown below. The result is then an expression of how much you need to turn up the level compared to normal for the patient to be able to repeat 50%. The calculation is based on the *m curve* if using multi syllabic words and the *s curve* if using single syllabic words.

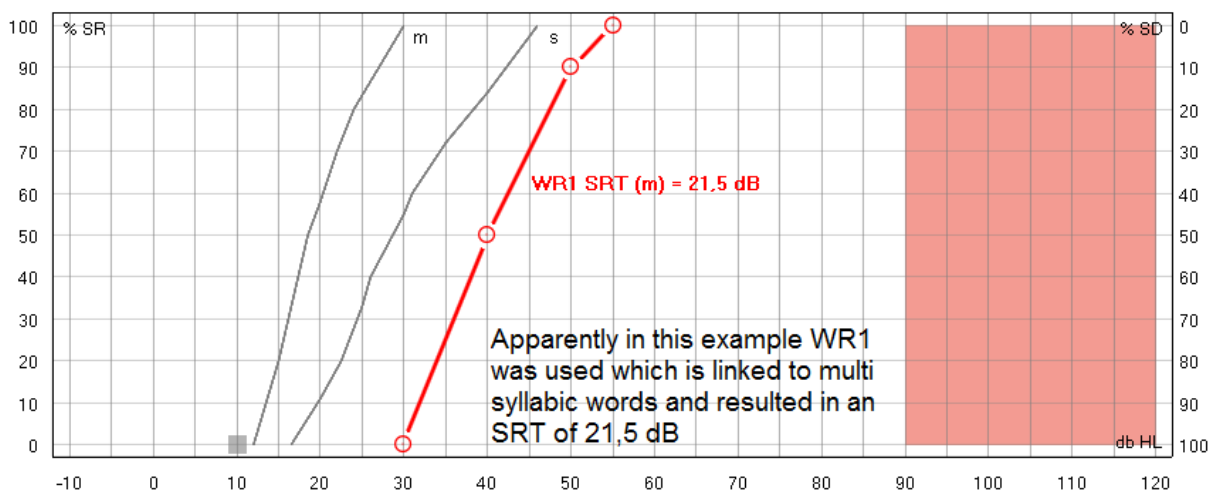

Note that the norm curves change based on the speech material. You must therefore ensure that WR1, WR2 and/or WR3 is linked to single or multisyllabic words to show the SRT (see section 1.6.2.3). If no stimulus is linked to the WR curves, no SRT will be shown on the speech screen.

- **Table Mode:** If selecting Table Mode, the test results are displayed in a table. When clicking “store” the intensity level is shown in the table. Unlike Graph mode no calculation of the SRT takes place. The table mode records the level at which you found the SRT. When changing *Transducer*, *Test Type* (HL, MCL, UCL), and *Aided* (Aided or Binaural) a new SRT is recorded.



- 8) Under **Table mode settings** you can decide whether the testing should start with SRT, WR1, WR2, WR3, HL, MCL, or UCL. The type of speech material for each WR can be selected in the *Link stimulus types to WR curves* (see later in this section).

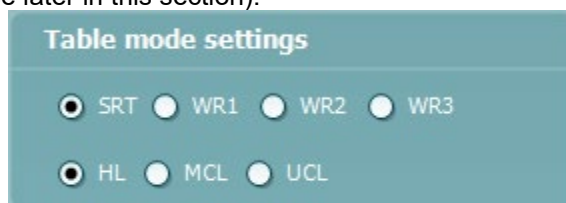

- 9) Under **Graph mode settings** you can decide whether the testing should start with WR1, WR2, WR3, MCL, or UCL. The type of speech material for each WR can be selected in the *Link stimulus types to WR curves* (see later this section).

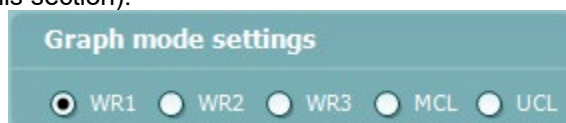

- 10) Under **Other settings** you can tick *Aided* if audiograms usually are obtained with hearing aids and/or *Binaural* if both ears are tested at the same time. This will result in a separate speech curve. Ticking *Synchrone* will activate the corresponding button in the front screen by default locking the distance in input level between Ch1 and Ch2 for masking purposes .
- 11) Under **Monitor** one or both channels may be ticked if monitoring is preferred. The level of the monitoring can be set using the slider bar.
- 12) Adjust the **Input Levels** for the selected input. It may be practical to set a default value in this screen if you always use the same input. Note that the input level can also be selected in the speech screen by pressing shift and adjusting the input to 0 VU (see section 1.5.5)



13) Under the **Other tab** additional speech test functions are available.

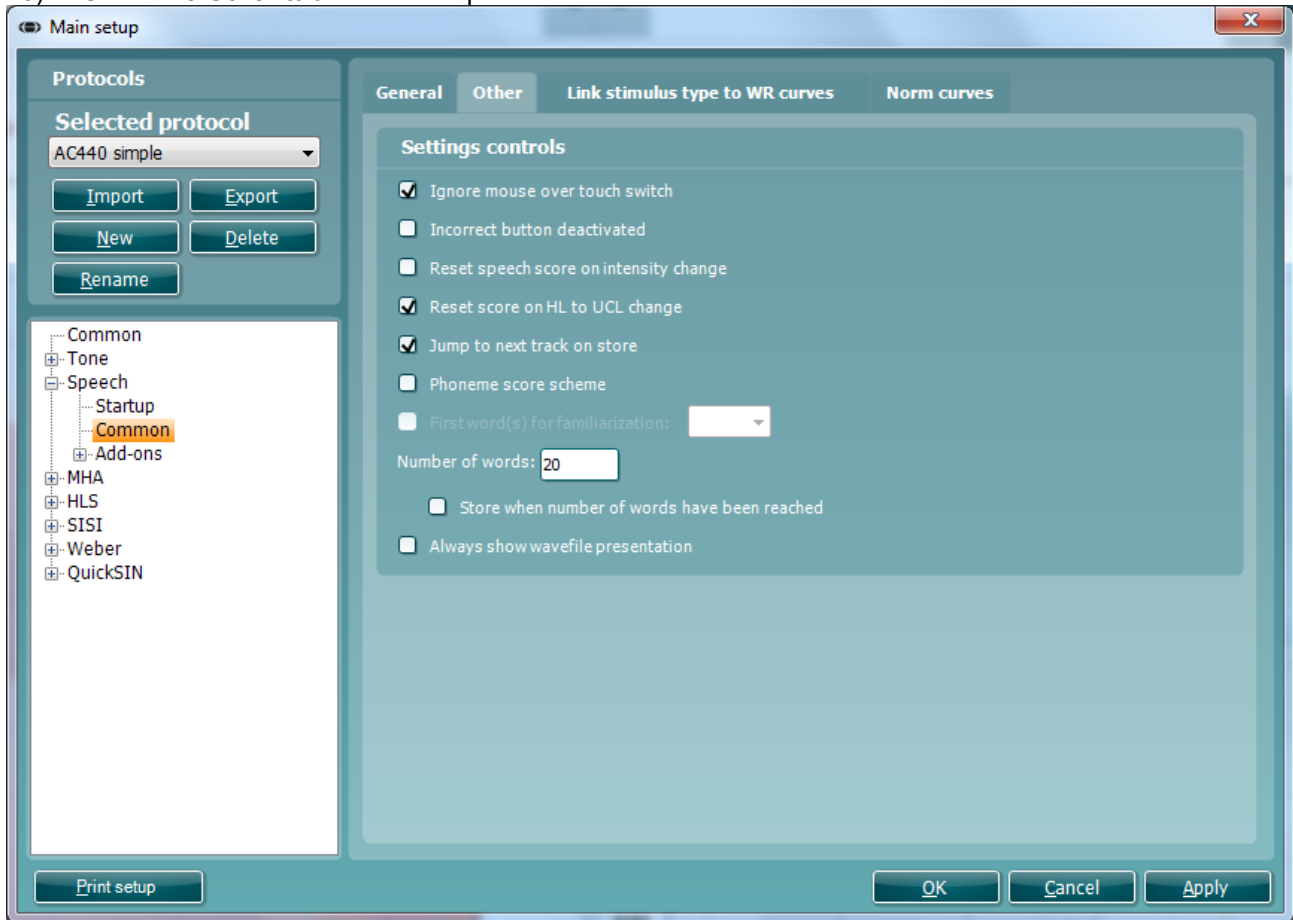

14) **Settings controls** includes the following options:

- *Ignore mouse over touch switch*: The AC440 will ignore the mouse touching the stimuli area. The function is embedded to avoid accidentally presenting a stimulus.
- *Incorrect button deactivated*: The incorrect button will be greyed, and only correct answers are counted.¹⁴
- *Reset speech score on intensity change*: The score will return to zero when the intensity is changed. This is useful to avoid accidentally storing a measurement point in the speech graph which was measured over different speech levels.
- *Reset score on HL to UCL change*: Ensures that if the test is toggled from HL to UCL the scoring will restart so that the UCL test does not build on the HL scoring.
- *Jump to next track on store* makes sure that a new word list is used for every point measured. In case word lists contain enough words for several points, it can be disabled. Notice that the word scoring can be reviewed by hovering the mouse over measured data points. It however only shows the words of the list in which the point started its measurement.
- *Phoneme score scheme*: Allow phoneme scoring during the speech test. The front screen will allow you to specify if 0, 1, 2, 3 or 4 phonemes are correctly repeated as illustrated below.

¹⁴ This may be useful if testing with wave files. In the wave file settings, you can set time limits so that after a certain period the word will be scored as incorrect. In this case the incorrect button is not needed

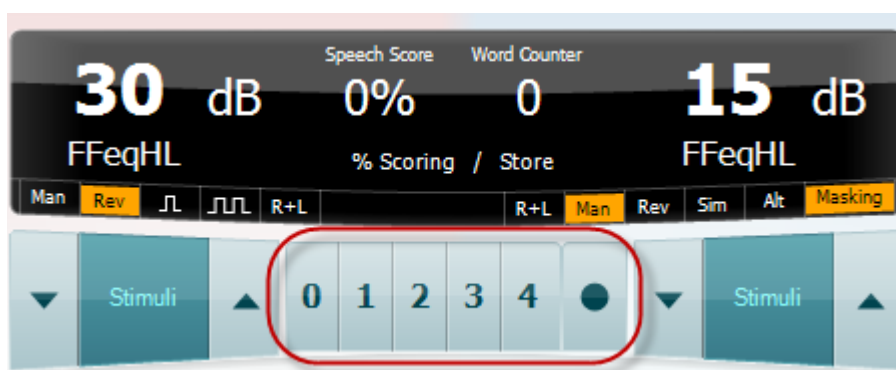

- **First word(s) for familiarization:** Set several “practise words” using the dropdown list (if *Phoneme score scheme* is ticked). If for example set to 3, the first three words will not be calculated in the final score as these are trial words.
- **Number of words:** Type in several words for the actual scored test. Note that this will be ignored when using wave files since the number of words in this case will be dependent on the selected speech material.
- **Stop when number of words has been reached** automatically stores the point after reaching the number of words that is indicated at *number of words*.
- **Always show wavefile presentation** assures that your preferred wave files are also shown on screen when selecting microphone as input.

15) Linking a type speech material to a WR curve:

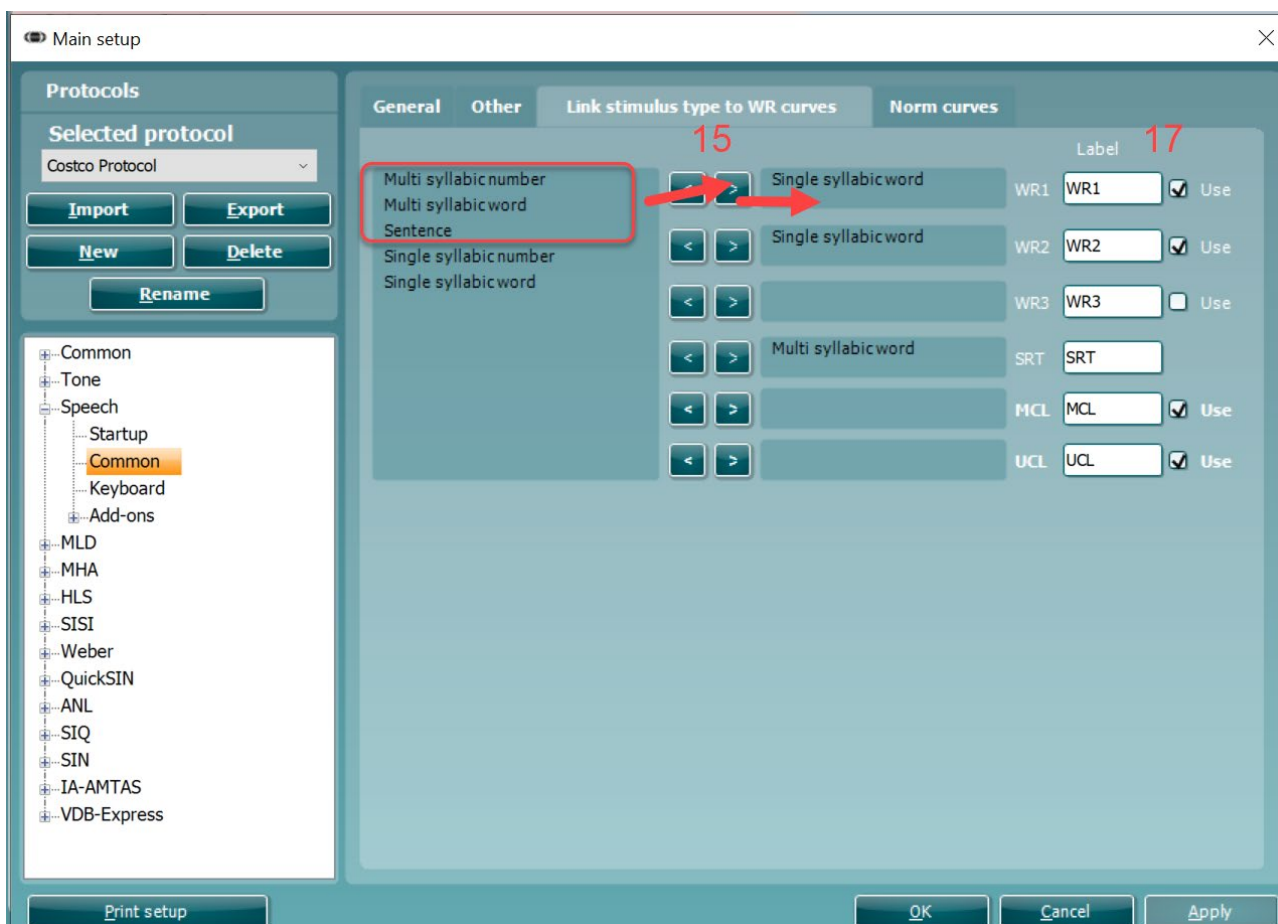



Under the **Link stimulus to WR curve** tab a certain type of speech material can be linked to the individual WR curves. If a clinic for example always uses multi syllabic numbers for WR1 and single syllabic words for WR2, you can link these materials to the curves and corresponding buttons in the front screen.

- Mark the type of material in the selection list
 - Click on the arrow pointing towards the WR curve to which the material should be linked
 - The material will then jump to the selected WR
- 16) Unlinking a type of speech material from a WR curve:
- Mark the type of material
 - Click on the arrow pointing back to the selection
 - The material will then jump back to the selection list
- 17) **User defined WR labels** allow you to name or label the speech material which will then be selectable for the print layout (see 4.1.1 for how to make a personal print layout). Additionally, for table mode testing the check boxes indicate which labels are available as buttons in the test screen.
- 18) Under the **Norm curves** tab the norm values appearing in the speech graph can be changed.

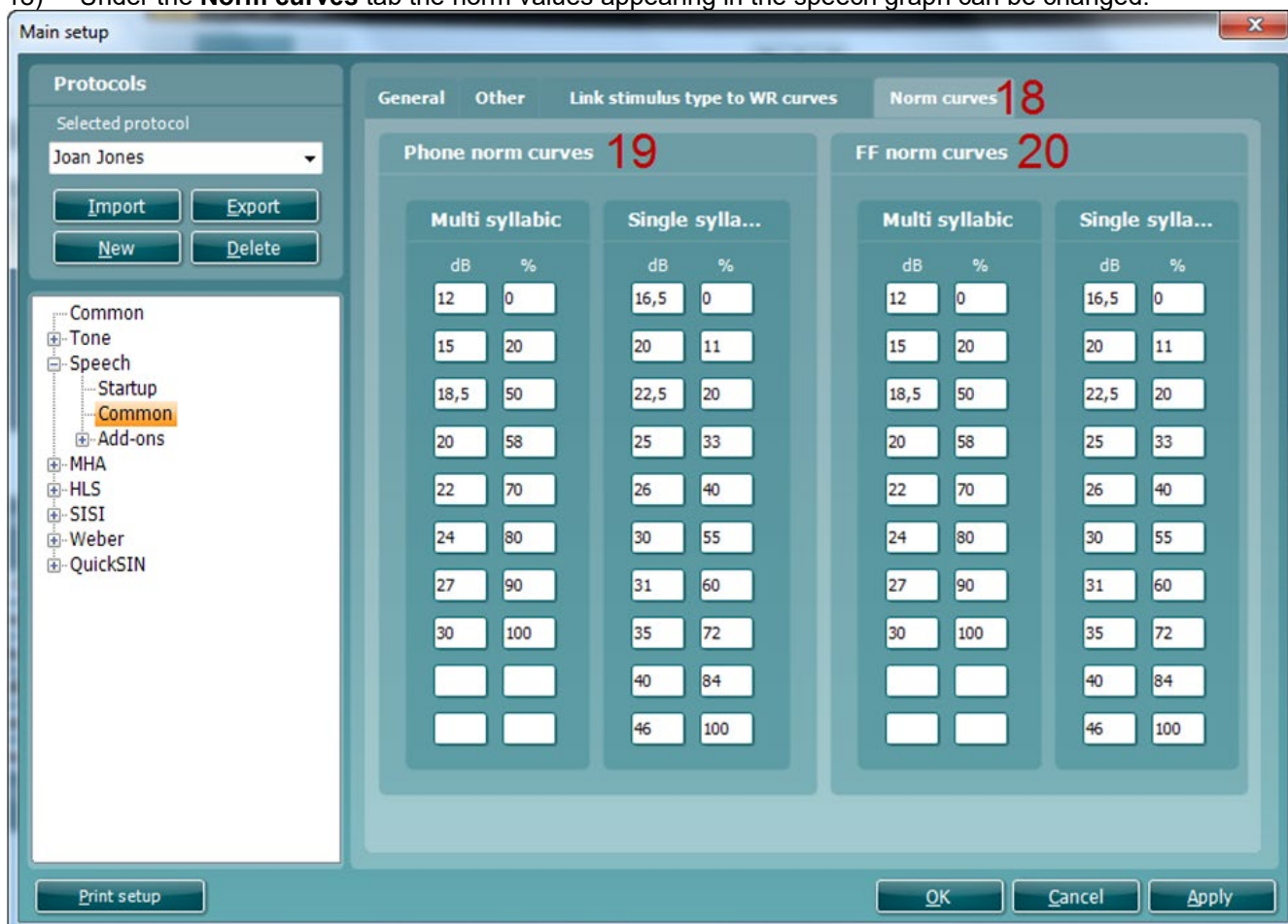

For **Phone norm curves** both *Multi syllabic* and *Single syllabic* norm values for speech tests obtained with head phone can be edited or replaced with other norm material.

19) For **FF norm curves** both *Multi syllabic* and *Single syllabic* norm values for speech tests obtained in free field can be edited or replaced with other norm material.



Add-ons

- 20) To enter the *Add-on options for speech testing* unfold the **Speech** options and click *Add-ons*. In this screen the AC440 can be setup to do speech testing using wave files¹⁵. Upload the wave files to the PC (as described in Appendix 1).
- 21) Select your speech material in the *Speech CD name* dropdown list. Selecting the dash '-' results in not having word lists available in the test screen.

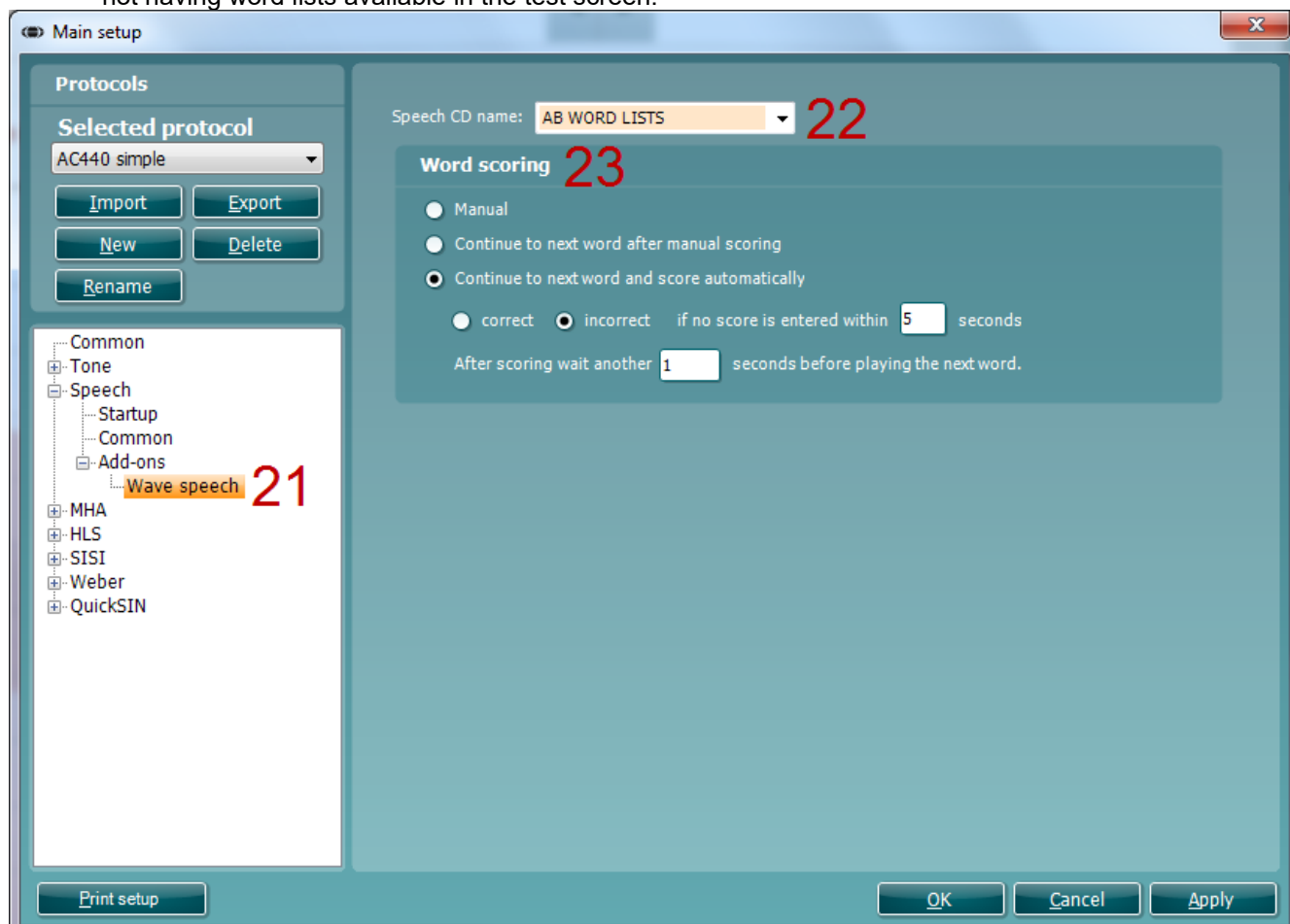

22) **Word scoring** includes the following options:

- *Manual*: Full manual control over the speech test, which is initiated, stopped, and scored manually.
- *Continue to next word after manual scoring*: Presents the next word, number, or sentence immediately after you have scored the previous word to be either correct or incorrect.
- *Continue to next word and score automatically*: The AC440 can be timed to wait for a certain number of seconds before continuing with the next word, number, or sentence regardless of whether it the previous work was repeated correctly or incorrectly. Additionally, you can decide whether the word, number, or sentence should be assumed *Correct* or *Incorrect* when continuing the test if no score has been entered.

In the white section below, you can specify the exact duration of the pause between clicking the correct button and presenting the next word, number, or sentence by entering the desired number of seconds.

After scoring wait another seconds before playing the next word.

¹⁵ Speech testing with wave files is an additional license (ISF440)



1.7.2.4 MHA counselling¹⁶ setup

Start-up

To enter the *Start-up* options for MHA counselling unfold the **MHA** options and click *Start-up*. **Talk back** can be enabled by ticking the check box (as described in section **Error! Reference source not found.** above).

Common

To enter the *Common* options for MHA counselling unfold the **MHA** options and click *Common*.

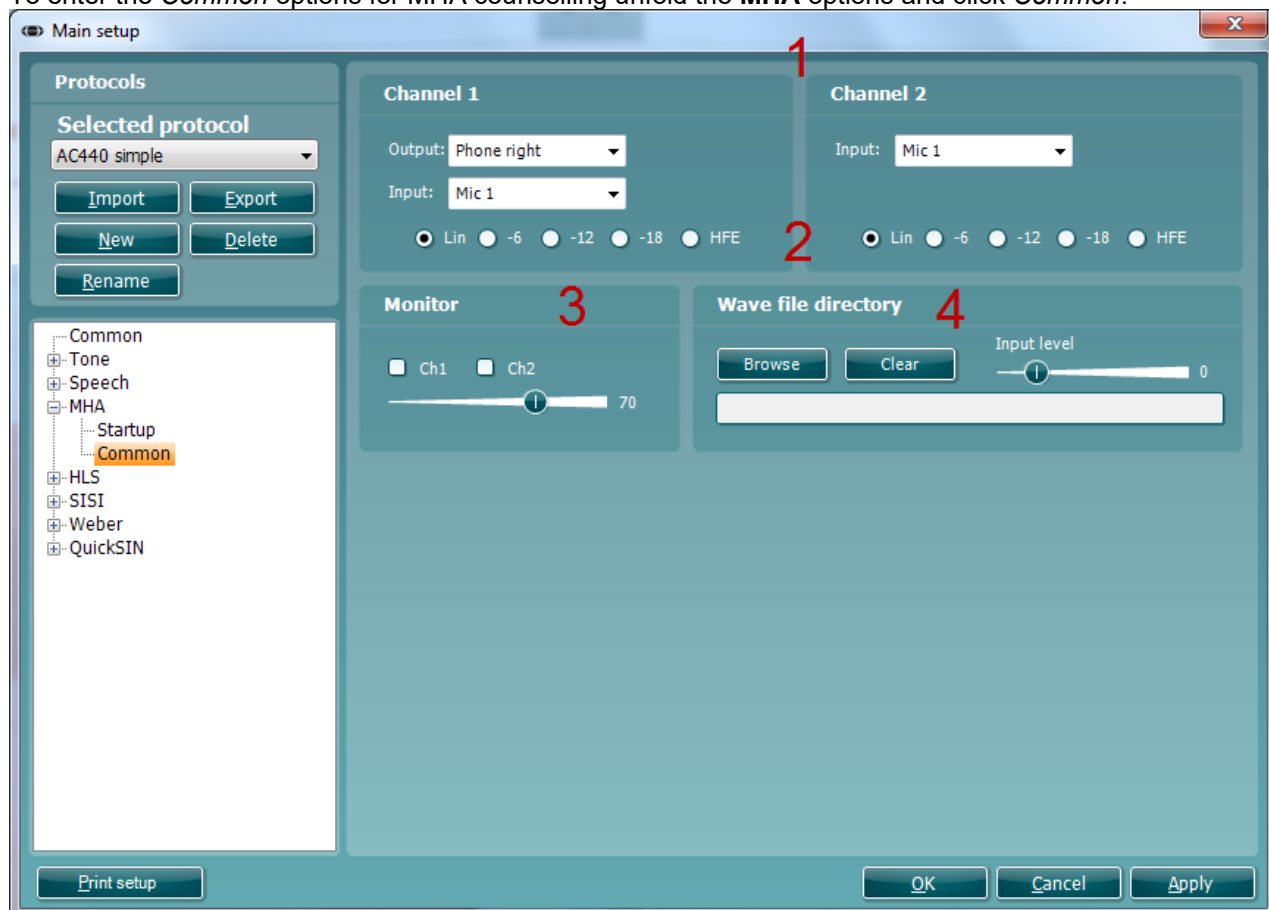

- 1) Set the output and input for channel 1 and the input for channel 2 under **Channel 1** and **Channel 2 Input** using the dropdown lists. The chosen output for channel 1 will automatically also apply for channel 2.
- 2) Select the default start filter. The different filters are illustrated below:

<i>Lin</i>	no filtering
-6 per octave	Minor high pass filtering
-12 per octave	Minor - Medium high pass filtering
-18 per octave	Medium – Major high pass filtering
<i>HFE</i> (-24 per octave)	Major high pass filtering

¹⁶ Master Hearing Aid (MHA) requires an additional software license.

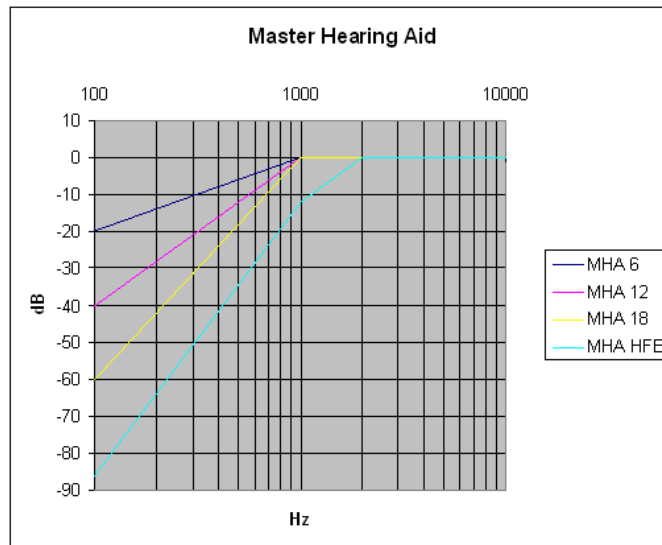

- 3) Under **Monitor** one or both channels may be ticked if monitoring is preferred. The level of the monitoring can be set using the slider
- 4) If **Wave files** are chosen as input, you can browse for them by clicking *Browse*. If a group of wave files are already chosen and you wish to browse for new ones, click *Clear*. The *Input level* of the wave files can be adjusted to the left using the slider.



1.7.2.5 HLS counselling¹⁷ setup

Start-up

To enter the *Start-up* options for HLS counselling unfold the **HLS** options and click *Start-up*. Determine the **Talk back** level using the check box to set the Talk back default .

Common

To enter the *Common* options for HLS counselling unfold the **HLS** options and click *Common*.

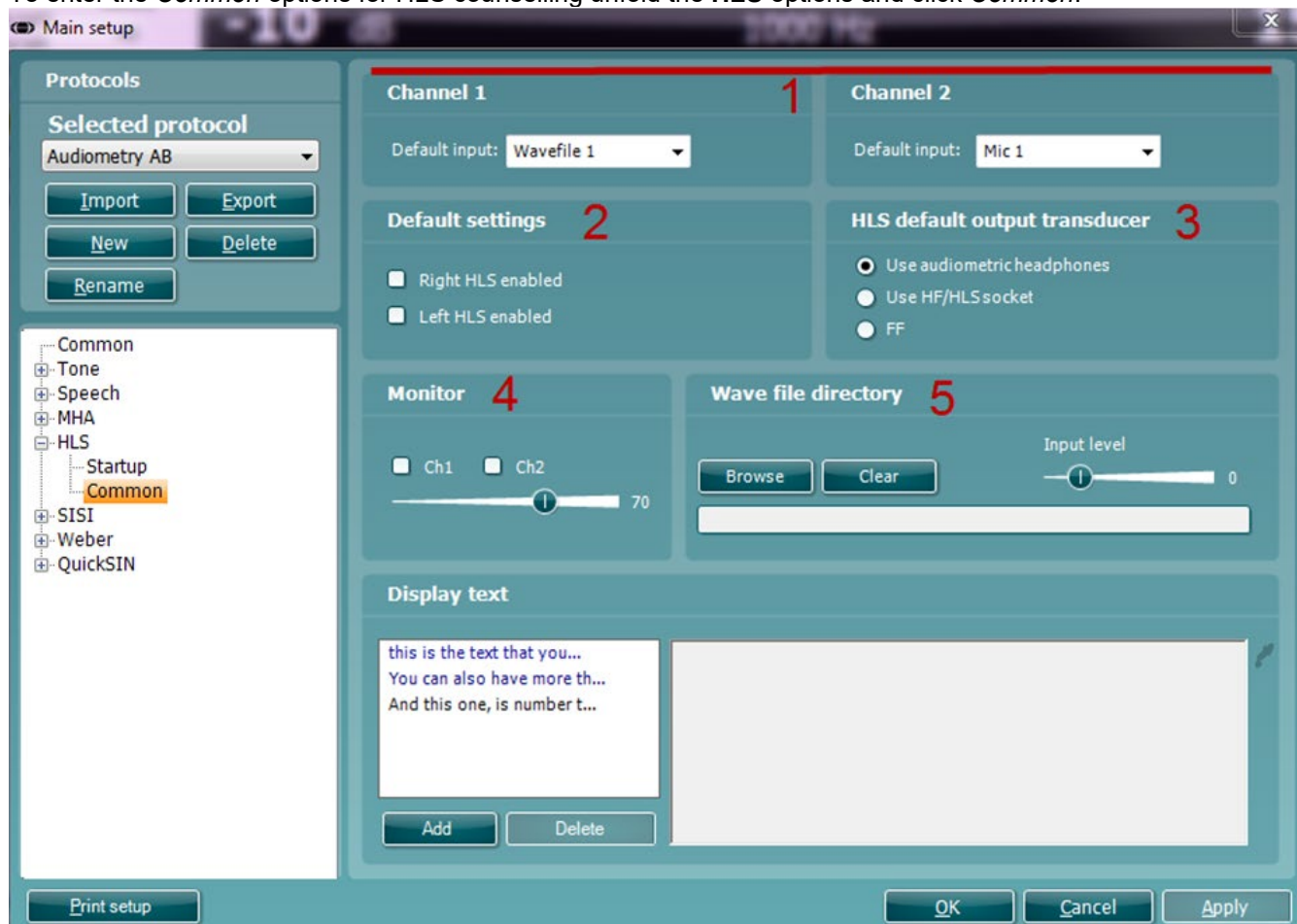

- 1) Set the *Default input* for **Channel 1** and the *Default Input* for **Channel 2** using the dropdown lists. Select if the test should be conducted through *Mic1*, *Mic2*, or *Wave files*.

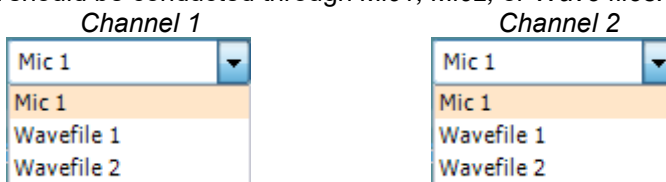

- 2) Under **Default settings** it can be decided whether the HLS should be enabled immediately when opened using the check boxes. If the check boxes are not ticked the HLS will need to be enabled manually using the *Right* and *Left* buttons in the front screen (see section 1.5.7).
- 3) Select the **HLS default headset**. If using the Equinox^{2.0} or Callisto™ hardware choose *between Use audiometric headphones* or *Use HF/HLS socket* if the high frequency headset is preferred.
- 4) Under **Monitor** one or both channels may be ticked if monitoring is preferred. The level of the monitoring can be set using the slider.

¹⁷ Hearing Loss Simulation (HLS) requires an additional software license.



- 5) If **Wave files** are chosen as input, you can browse for them by pressing *Browse*. If a group of wave files are already chosen and you wish to browse for new ones, press *Clear*. The *Input level* of the wave files can be adjusted to the left using the slider.

To setup the patient monitor text:

1. Go to **Menu | Setup | AC440 Setup**
2. Choose the protocol desired protocol to modify.
 - a. If choosing a default protocol, you will need to copy the existing settings and create a new one before modifying the settings
 - b. If choosing a custom protocol, you can modify the settings directly, without needing to copy
3. Go to **HLS | Common | Display Text**
4. Click Add, which will activate a cursor, type in the desired text. (The Add button changes to a Save button). Click Save when done.
5. To change the text color, click on the dropper icon
6. To save the text, click on Save
7. Multiple sentences and paragraphs can be added by steps 4 and 5
8. To Delete the entry, highlight the entry, and click Delete
9. Once finished, click on Apply to apply the changes
10. Click on the main Save button to save the setup changes

Adding an entry:

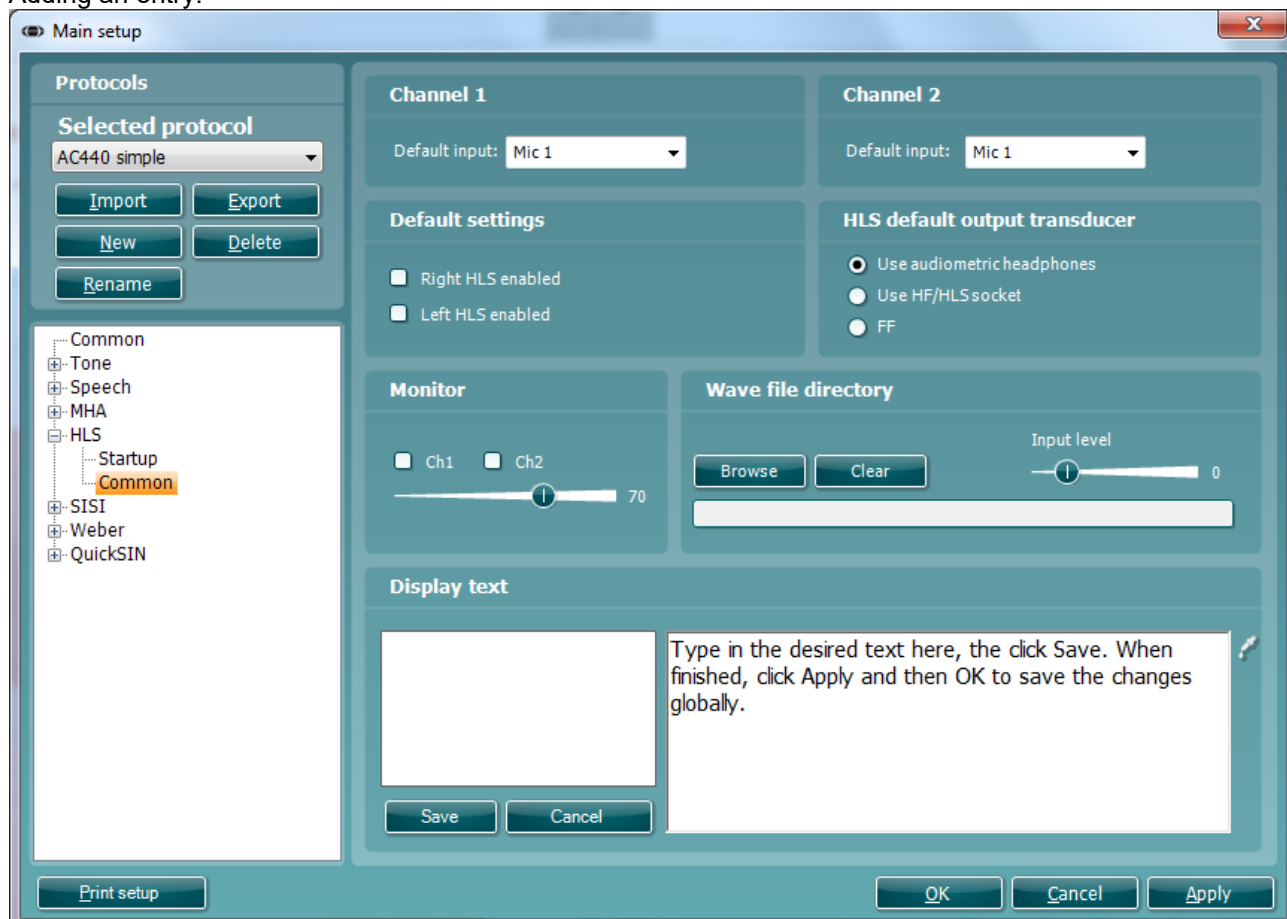



Deleting an entry:

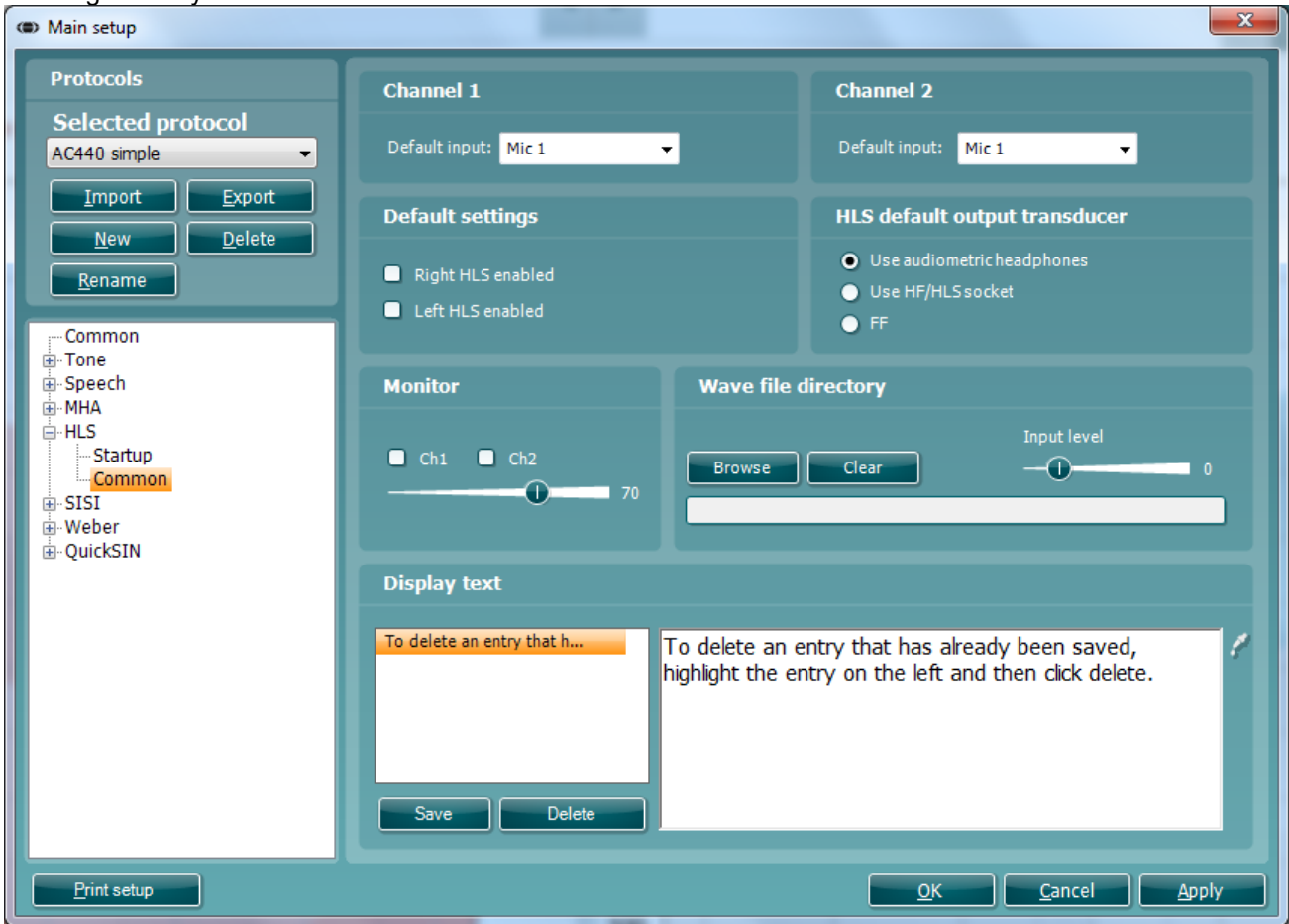

Using the patient monitor text feature:

1. Choose the protocol in which the Patient Monitor Text has been activated
2. Go to the Menu | Tests | HLS
3. Ensure that Mic 1 transducer is chosen
4. Go to Counselling Overlays window and click on the Patient Monitor Text button
5. This will launch the Patient Monitor with including text.
6. Choose the text to be used during the hearing loss simulation
7. Use the Zoom slider to make text bigger or smaller



The screenshot shows the Interacoustics software interface. At the top, there are two channels, Channel 1 and Channel 2, both set to 30 dB HL. Below this is a graph titled "Phone right - Mic 1" showing a hearing loss curve. A "Patient Monitor" window is overlaid on the graph, displaying text: "Use this text to help during the hearing loss simulation to make it easier for the patients significant other to read from, rather than asking them to speak spontaneously." Red arrows point to various controls: "Patient Monitor text button" points to the text in the window; "Zoom and text selection can also be controlled here" points to a dropdown menu in the bottom left; "Use the slider to increase/decrease the size of the text" points to a slider in the bottom right; and "Use the dropdown to select the desired text" points to a dropdown menu in the bottom right.



1.7.2.6 SISI testing¹⁸ setup

Start-up

To enter the *Start-up* options for SISI testing unfold the **SISI** options and click *Start-up*. The **Talk back** level can be determined using the check box (as described in section **Error! Reference source not found.**)

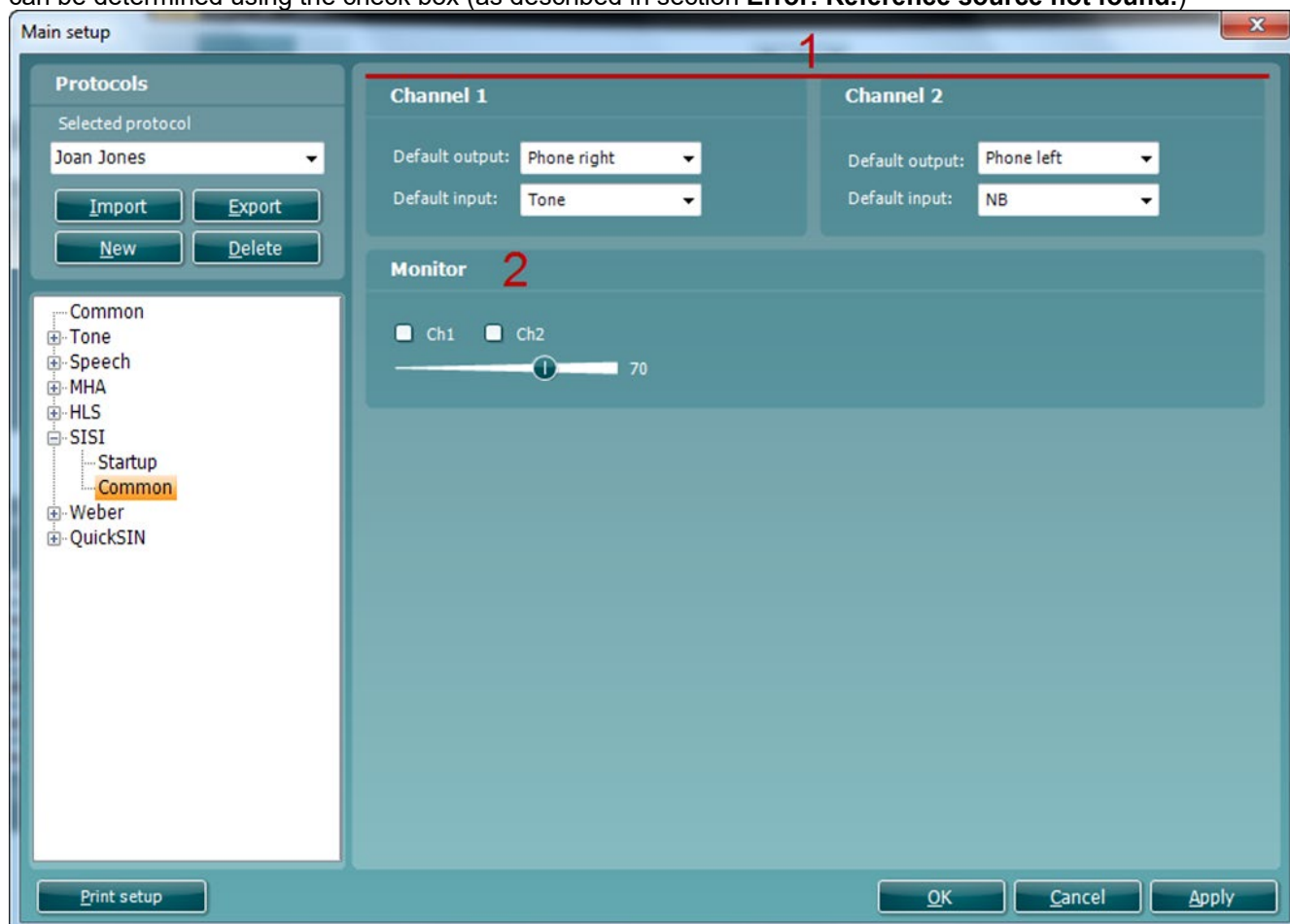

Common

To enter the *Common* options for SISI testing unfold the **SISI** options and click *Common*. On the screen the most common SISI settings can be defined.

- 1) Set the default output and default input for **Channel 1** and **Channel 2** using the dropdown lists. See the selections below:

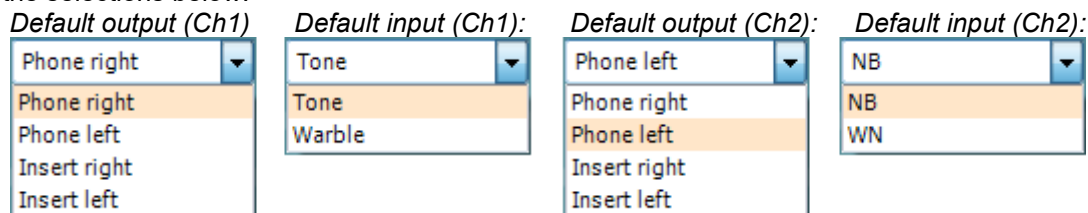

- 2) Under **Monitor** one or both channels may be ticked if monitoring is preferred. The level of the monitoring can be set using the slider

¹⁸ SISI requires an additional software license.



1.7.2.7 Weber testing setup

Start-up

To enter the *Start-up* options for Weber testing unfold the **Weber** options and click *Start-up*. The **Talk back** level can be determined using the check box as described in section

Common

To enter the *Common* options for Weber testing unfold the **Weber** options and click *Common*.

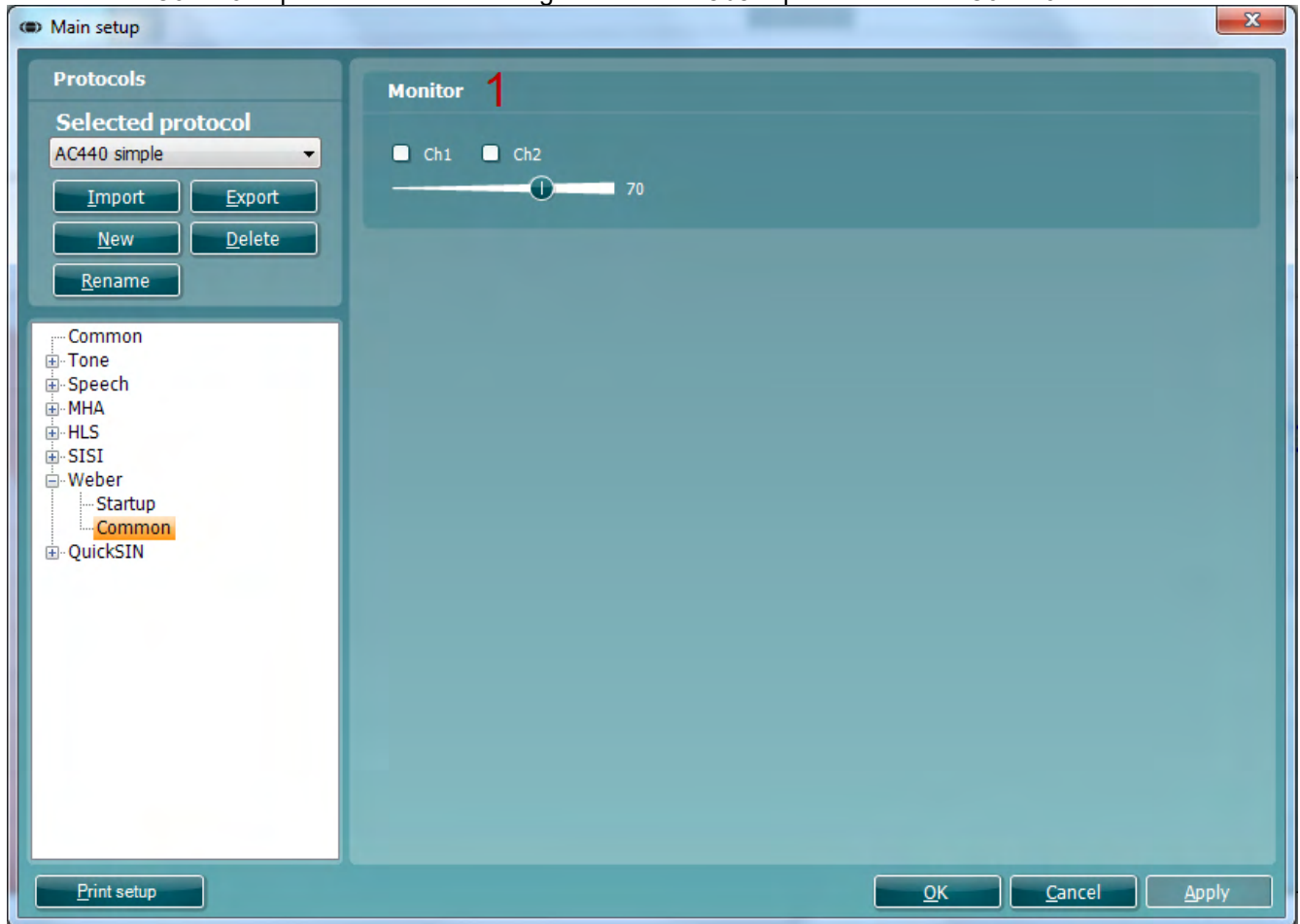

- 1) Select **Monitor** for channel 1 and channel 2 using the check boxes and adjust the level using the slider.



1.7.2.8 QuickSIN¹⁹ setup

Start-up

To enter the *Start-up* options for QuickSIN testing unfold the **QuickSIN** options and click *Start-up*.

- 1) Select the default output for **Channel 1** and **Channel 2** using the dropdown lists.
- 2) The **Talk back** level can be determined using the check box.

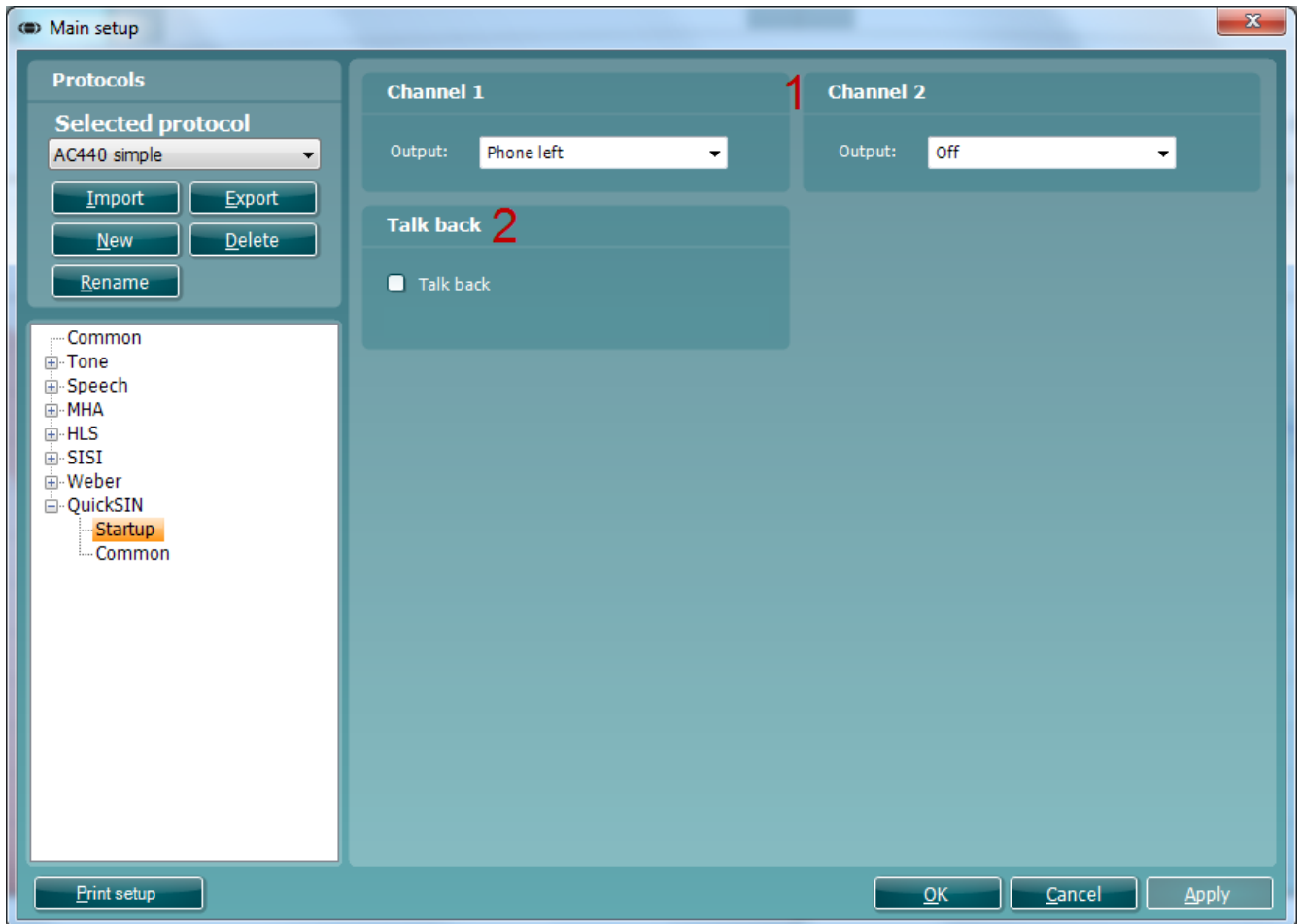

¹⁹ QuickSIN requires an additional software license.



Common

To enter the *Common* options for QuickSIN testing unfold the **QuickSIN** options and click *Common*.

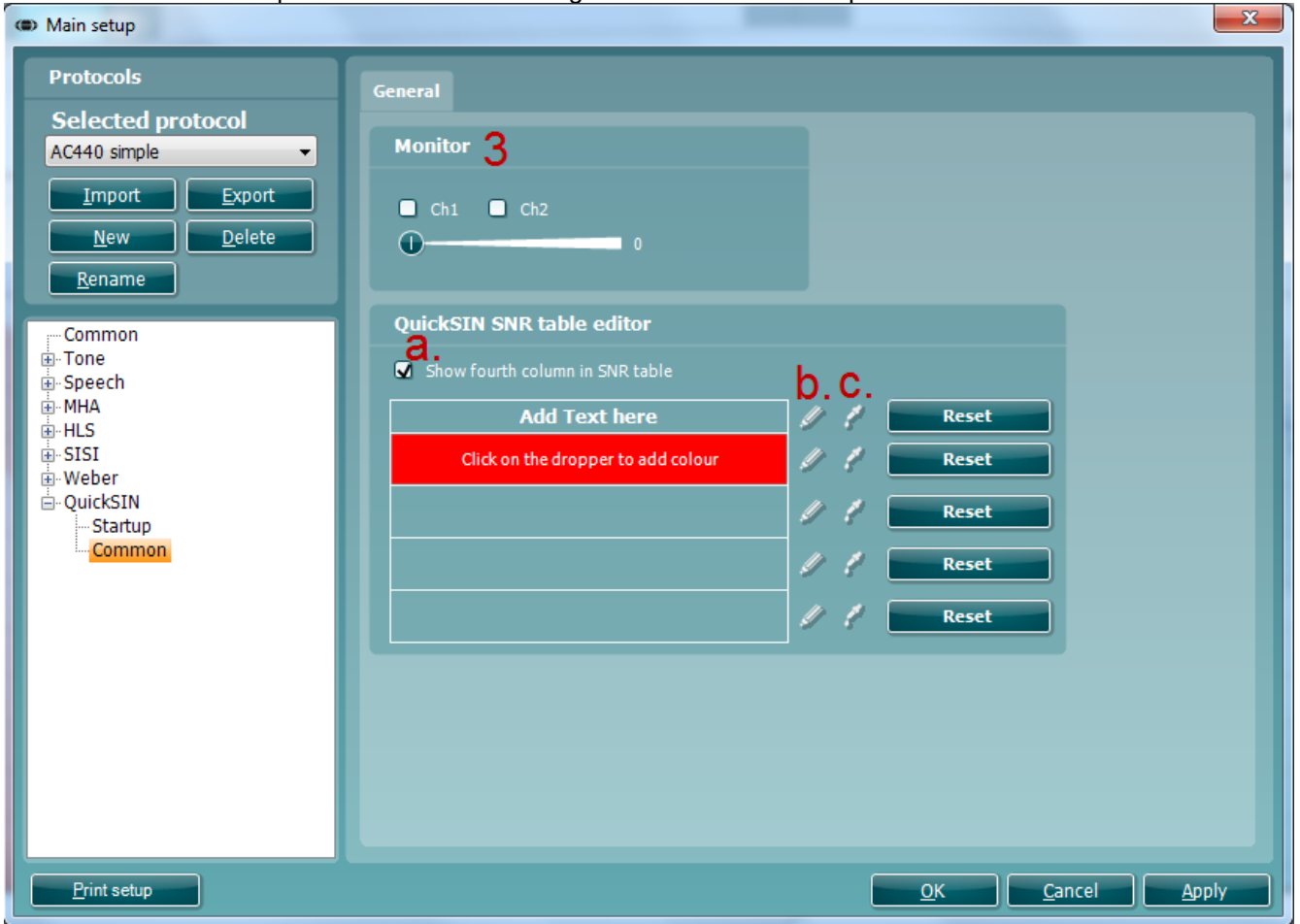

- 3) Select **Monitor** for channel 1 (Ch1) and channel 2 (Ch2) using the check boxes and adjust the level using the slider.

Adding a fourth column to the SNR loss definitions table:

- a. Insert a checkmark in the “show fourth column” box
- b. Click on the pencil icon to enter text in the text box
- c. Click on the dropper icon to add color to the text box

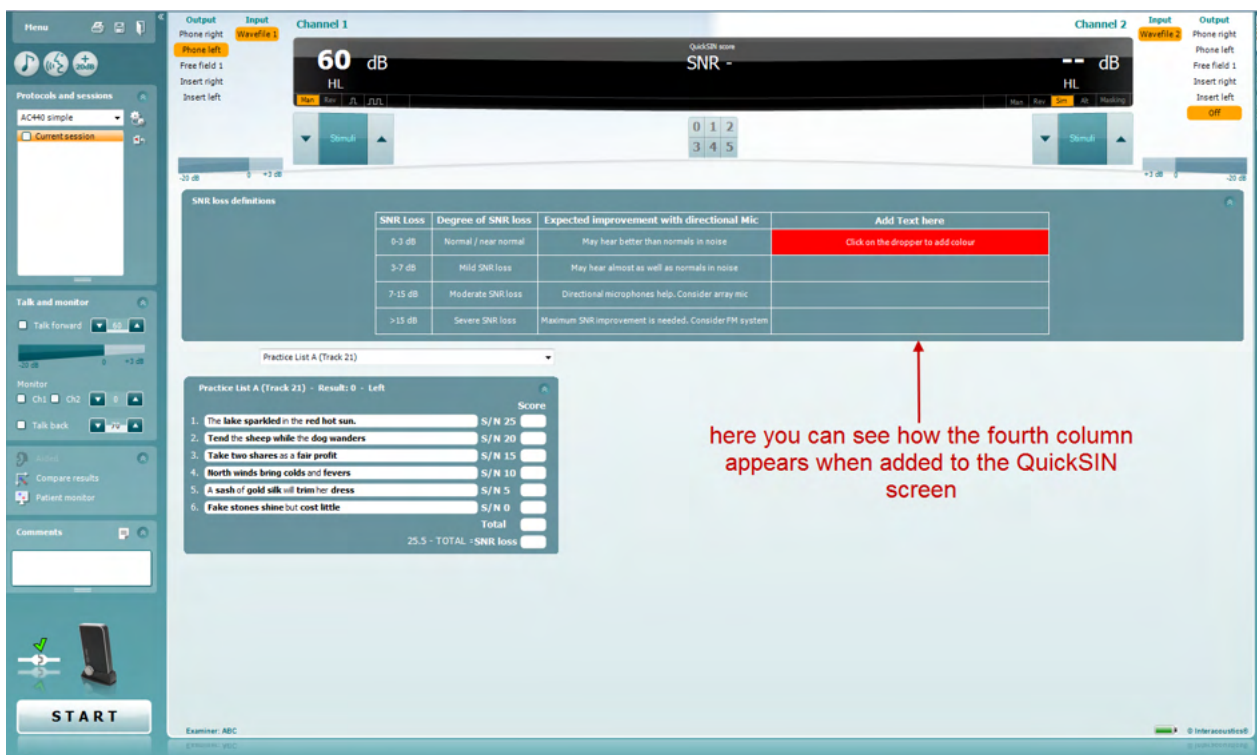

here you can see how the fourth column appears when added to the QuickSIN screen

1.7.2.9 ABLB/Fowler and Stenger setup

ABLB/Fowler and Stenger can be performed by adjusting the Tone or Speech settings in the front screen. (See 1.7.2.2 section and 1.7.2.3). There is no dedicated Test Screen for these tests.

1.7.2.10 TEN test²⁰ setup

For your convenience, the TEN test can be selected as a pre-defined test protocol which is made according to the methods of Brian Moore (see Appendix 3). Depending on which regional settings were selected during the software installation, a TEN test protocol can be selected in the *List of defined Protocols*:

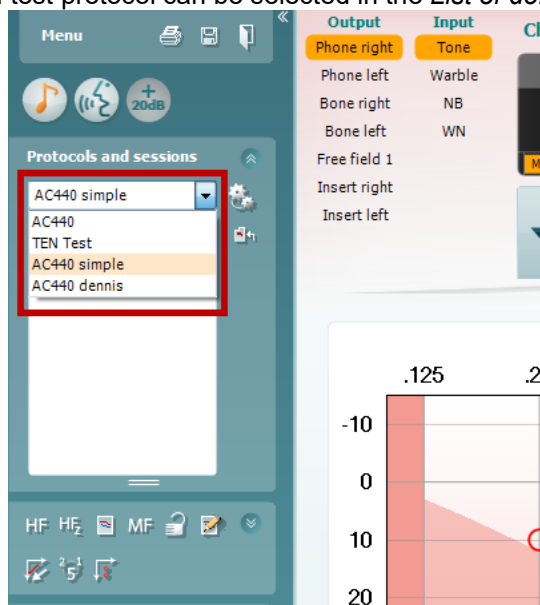

²⁰ TEN test requires an additional software license



Note: If a TEN test protocol is not visible it can be made available by selecting **Menu | Setup | Show/Hide protocols**.

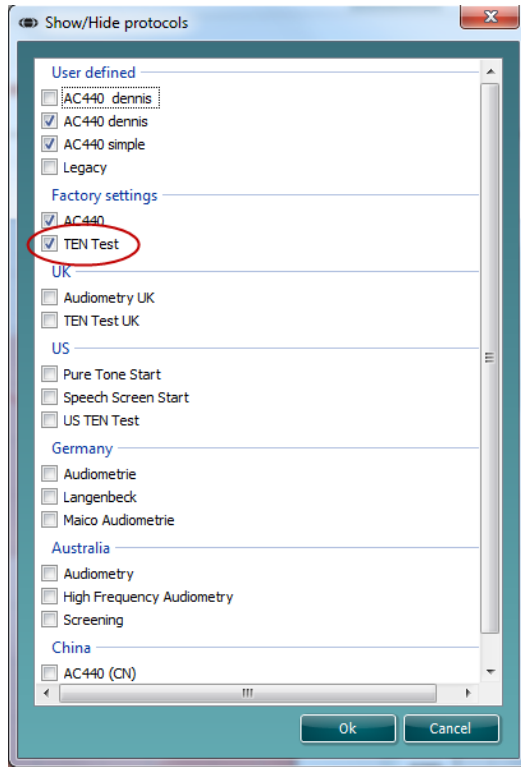



1.7.2.11 ANL test setup

Start-up

To enter the *Start-up* options for ANL testing unfold the **ANL** options and click *Start-up*.

- 1) Select the default output for **Channel 1** from the dropdown list.
- 2) The **Talk back** level can be determined using the check box.

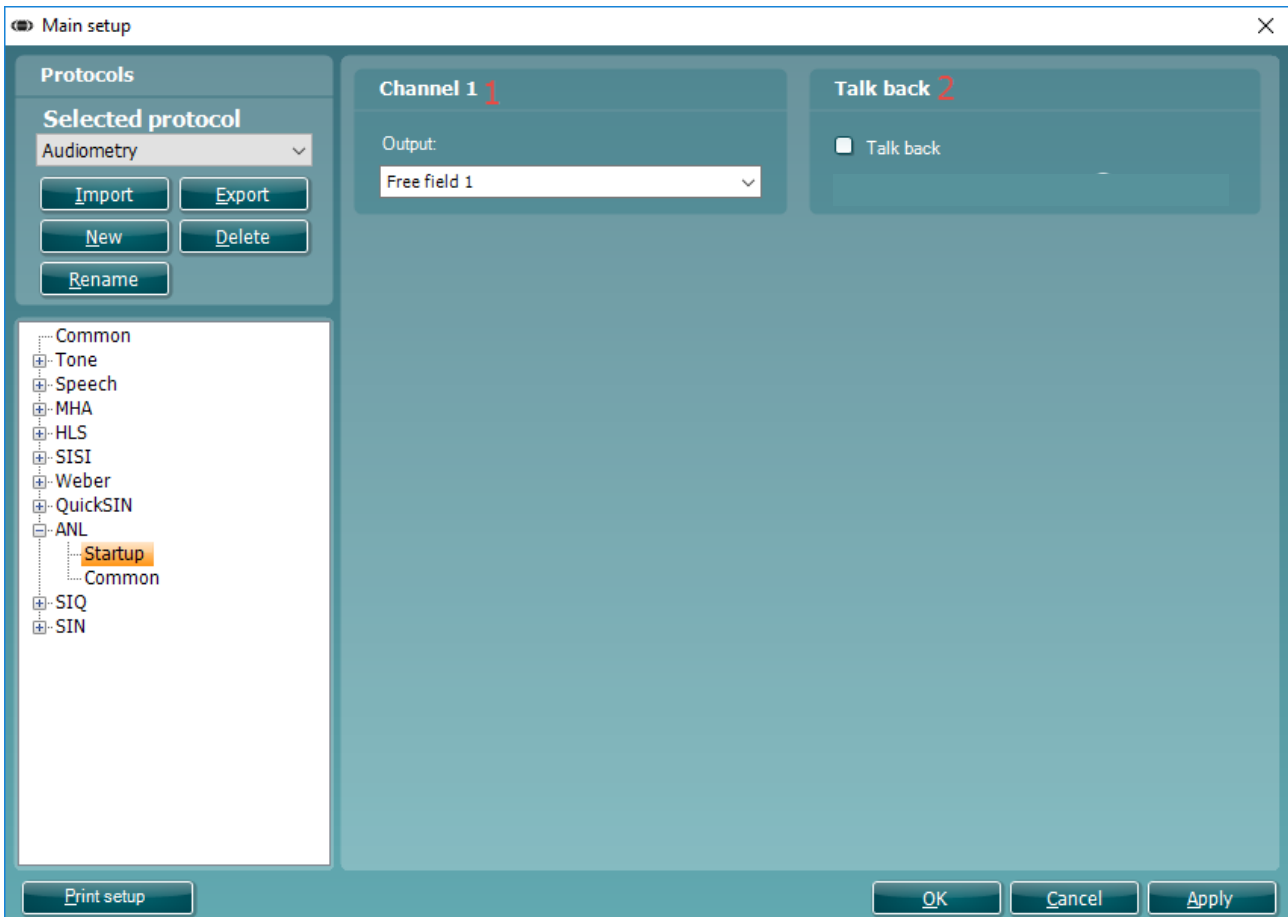



Common

To enter the *Common* options for ANL testing unfold the **ANL** options and click *Common*.

- 1) Select your desired **Channel 1 input** via the Input dropdown list.
- 2) Select your desired **Channel 2 input** via the Input dropdown list.
- 3) Choose your **Speech Material** via this section. The options you are available to select correspond to the material which is already available in your Speech Audiometry test screen. This requires that the material has been extracted via the speech extraction tool.

The dropdown allows you to choose your CD Name but also the Track and individual Speech Fragment you wish to use.

It is important for the running of the test that each dropdown has been selected.

- 4) Choose your **Intensity steps** via this section. This will alter the step size you can change your stimulus by.



1.7.2.12 SIQ test setup

Start-up

To enter the *Start-up* options for SIQ testing unfold the **SIQ** options and click *Start-up*.

- 1) Select the default output for **Channel 1** from the dropdown list.
- 2) Select the default output for **Channel 2** from the dropdown list.
- 3) The **Talk back** level can be determined using the check box.

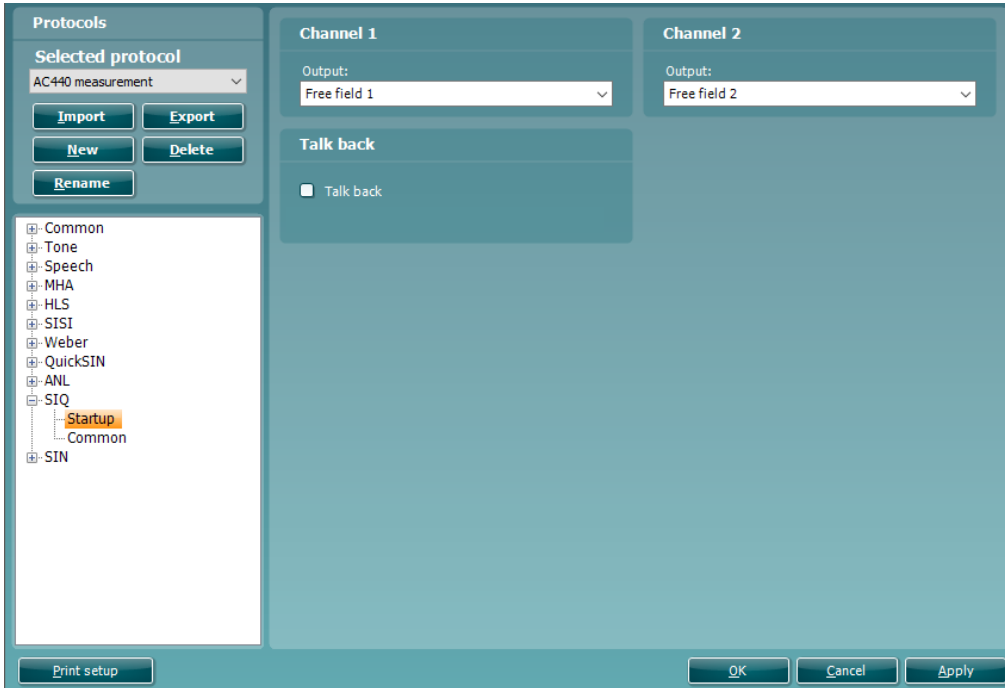



Common

To enter the *Common* options for SIQ testing unfold the SIQ options and click *Common*.

Main setup

Protocols

Selected protocol: AC440_DMIS

Import Export

New Delete

Rename

- Common
- Tone
- Speech
- MHA
- HLS
- SISI
- Weber
- QuickSIN
- ANL
- SIQ
 - Startup
 - Common**
- SIN

Channel 1 1

Input: Wavefile 1

Channel 2 2

Input: SN

Wavefile settings 3

Speech CD name: -

Material type: Single syllabic word

Randomise wavefile playlists before playing

Word scoring 4

Manual

Continue to next word after manual scoring

Continue to next word and score automatically

correct incorrect if no score is entered within 5 seconds

After scoring wait another 0 seconds before playing the next word.

SRT settings 5

Maximum number of stimuli used in the SRT calculation: 5

Minimum number of stimuli (after first correct answer) before validating SRT: 5

Adaptive settings 6

Conditioning step size: 6 dB

Adjustment step size: 3 dB

Print setup OK Cancel Apply

Main setup

Protocols

Selected protocol: AC440_DMIS

Import Export

New Delete

Rename

- Common
- Tone
- Speech
- MHA
- HLS
- SISI
- Weber
- QuickSIN
- ANL
- SIQ
 - Startup
 - Common**
- SIN

Speech CD name: -

Material type: Single syllabic word

Randomise wavefile playlists before playing

Word scoring 4

Manual

Continue to next word after manual scoring

Continue to next word and score automatically

correct incorrect if no score is entered within 5 seconds

After scoring wait another 0 seconds before playing the next word.

SRT settings 5

Maximum number of stimuli used in the SRT calculation: 5

Minimum number of stimuli (after first correct answer) before validating SRT: 5

Adaptive settings 6

Conditioning step size: 6 dB

Adjustment step size: 3 dB

Other Settings 7

Binaural

Print setup OK Cancel Apply



1.7.2.13 SIN test setup

Start-up

To enter the *Start-up* options for SIN testing unfold the **SIN** options and click *Start-up*.

- 1) Select the default output for **Channel 1** from the dropdown list.
- 2) Select the default output for **Channel 2** from the dropdown list.
- 3) The **Talk back** level can be determined using the check box.
- 4) The **Default SNR** section allows you to specify the start SNR level for your testing.

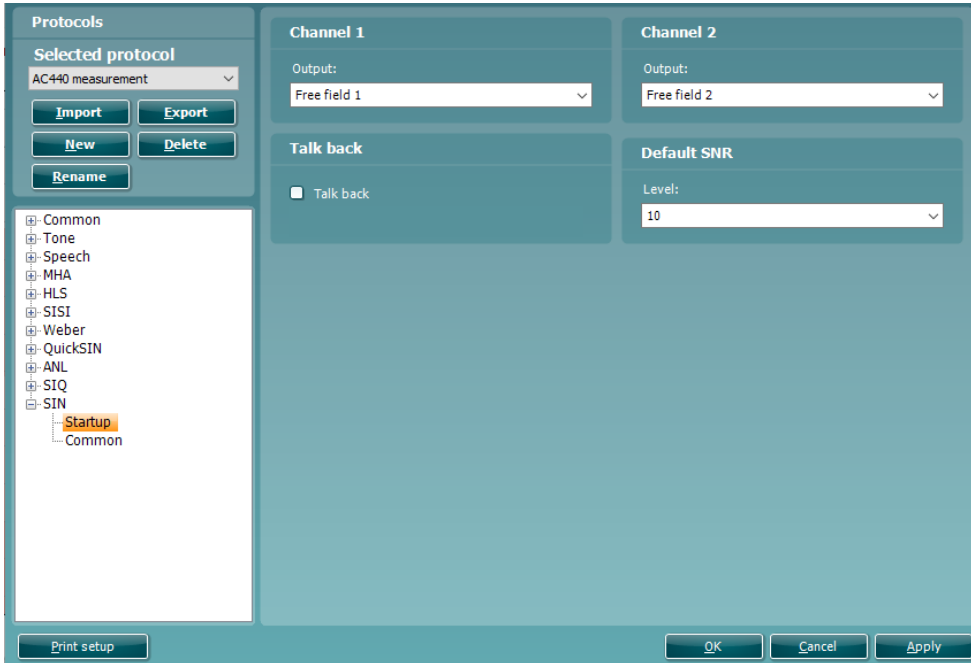

Common

To enter the *Common* options for SIN testing unfold the **SIN** options and click *Common*.

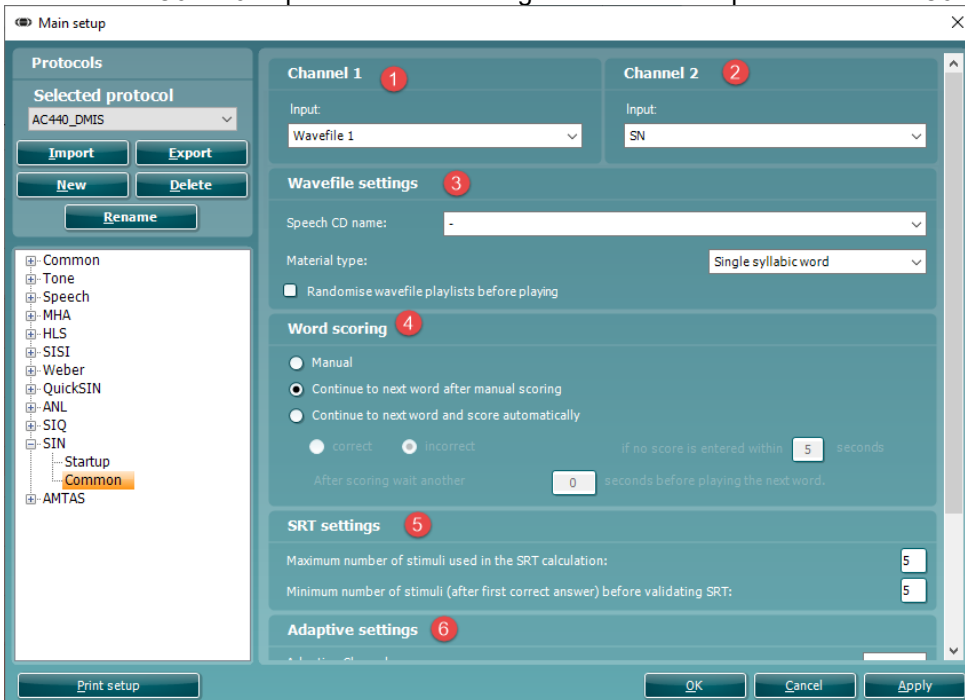

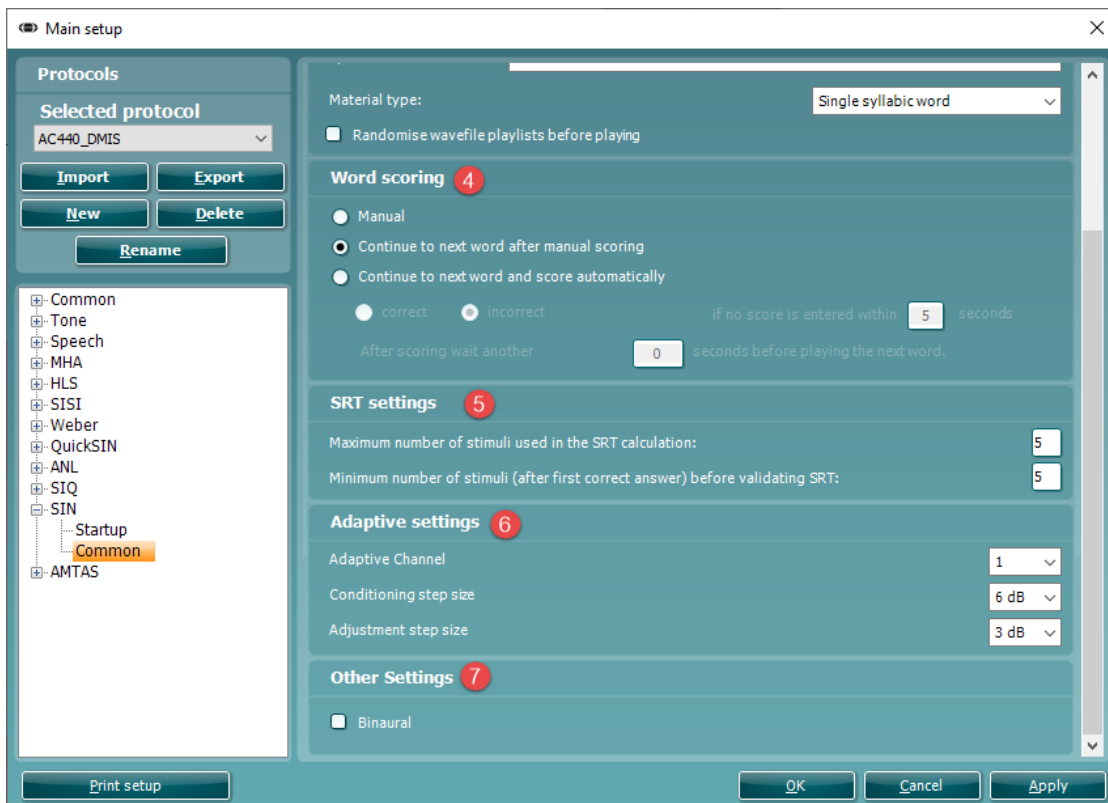

- 1) Select your desired **Channel 1 input** via the Input dropdown list.
- 2) Select your desired **Channel 2 input** via the Input dropdown list.
- 3) Choose your **Speech Material** via this section. The options you are available to select correspond to the material which is already available in your Speech Audiometry test screen. This requires that the material has been extracted via the speech extraction tool.
You can select your default **material type** in this drop down which will automatically make the system search for the relevant material for this type of test.
If you check the **Randomise wavefile playlists before playing** checkbox then the material will be played in a random order.
- 4) Specify how you would like the software to behave for the **Word Scoring** via this section. This will allow you to change the logic of the system depending on how the responses are scored.
- 5) The **SRT Settings** allow you to specify the max number of stimuli used for the SRT calculation and the minimum number of stimuli required after the first correct score before the system calculates an SRT score.
- 6) The **Adaptive Settings** allow you to specify the step size of both the conditioning step and the adjustment once the test has begun.
You can also specify which channel is adaptive – allowing you to choose if the signal or the noise will change according to the patients' response when performing the test.
- 7) The **Other Settings** allow you to default the test as Binaural.



1.7.2.14 VDB-express²¹ setup

Start-up

To enter the *Start-up* options for VDB-Express testing unfold the **VDB-Express** options and click *Start-up*.

- 1) Select the default output for **Channel 1** and **Channel 2** using the dropdown lists.
- 2) The **Talk back** level can be determined using the check box.

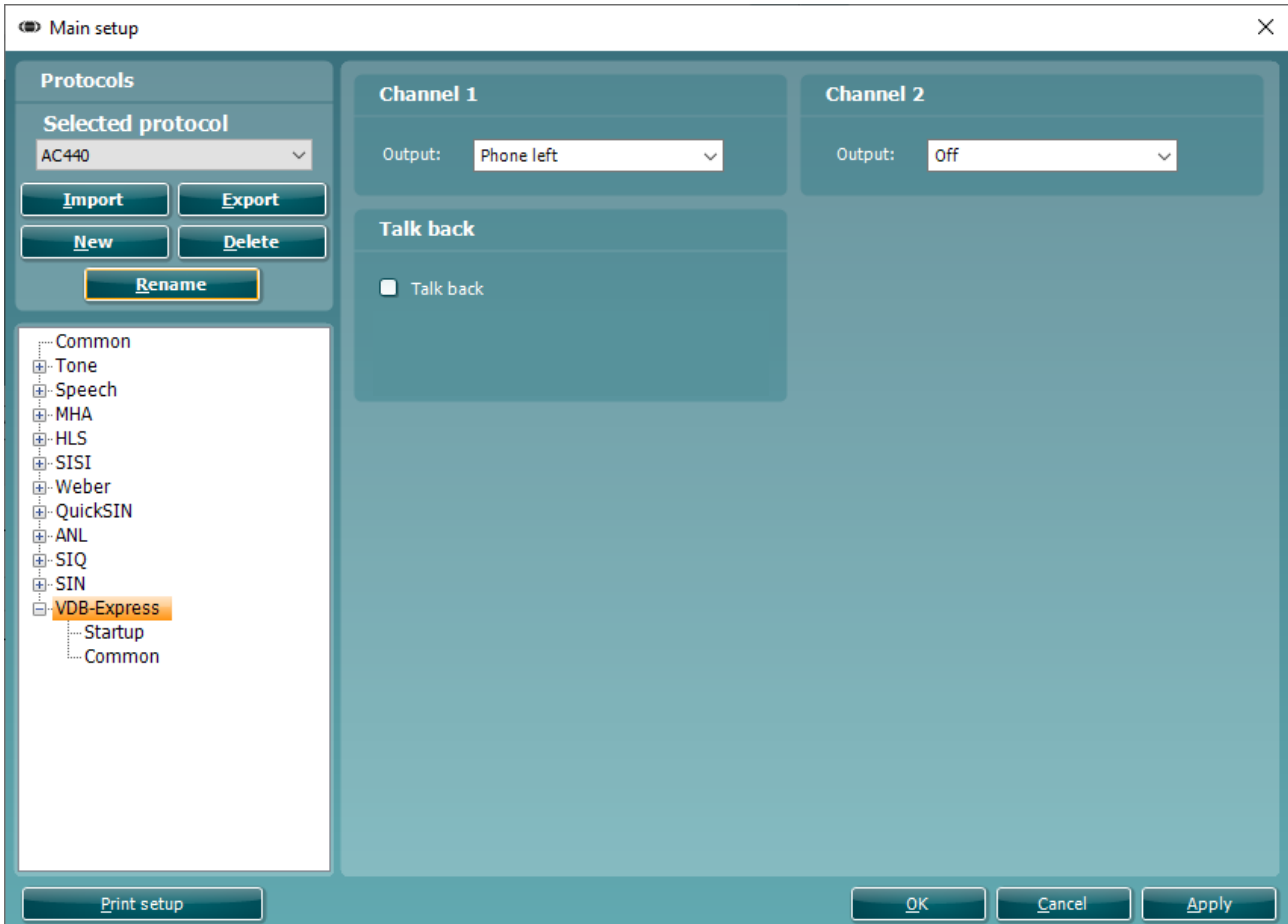

²¹ VDB-Express requires an additional software license.



Common

To enter the *Common* options for VDB-Express testing unfold the **VDB-Express** options and click *Common*.

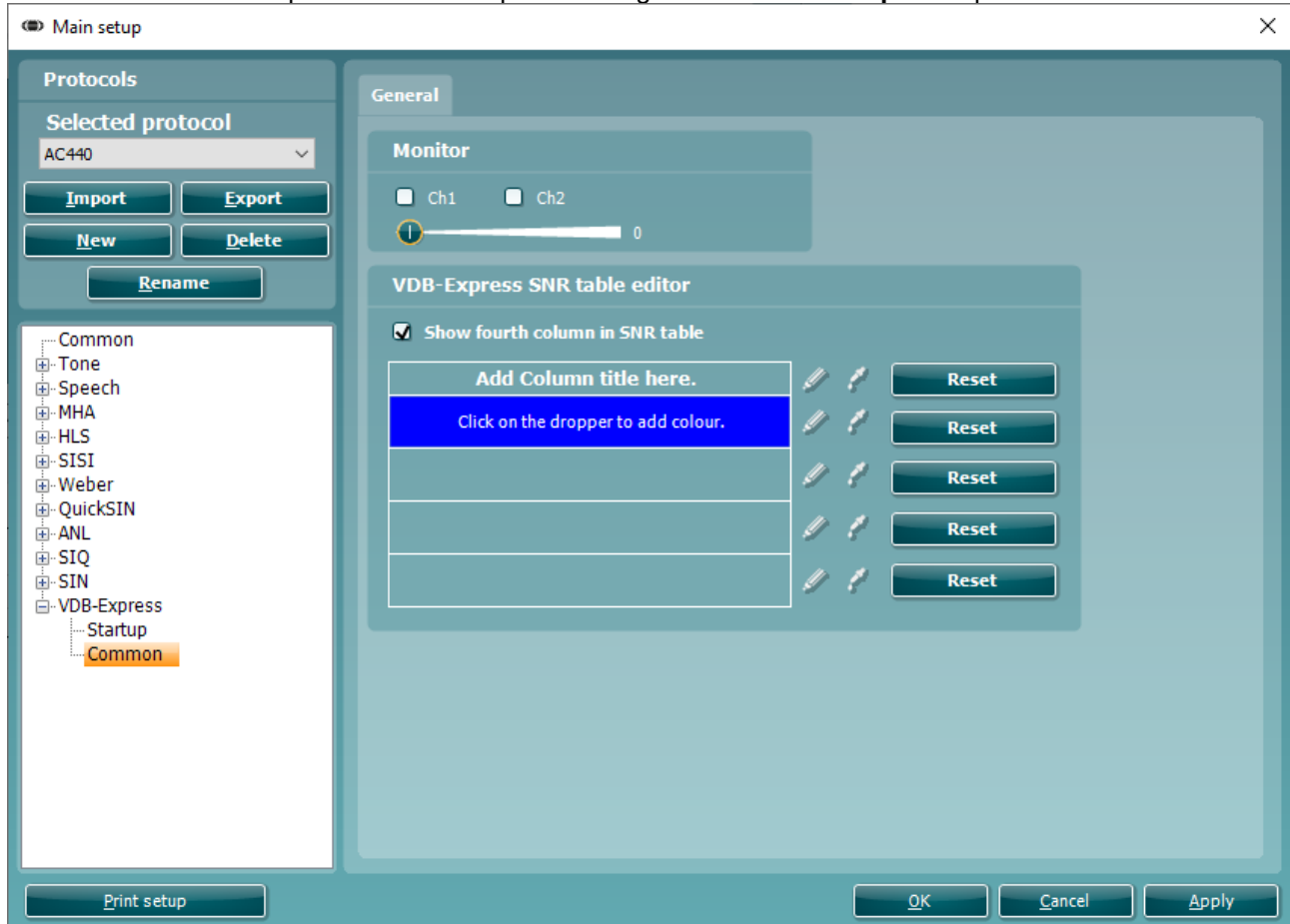

Select **Monitor** for channel 1 (Ch1) and channel 2 (Ch2) using the check boxes and adjust the level using the slider.

You have the option to add a fourth column to the SNR Loss definitions table to suggest certain amplification products or tiers of products which will support the patient's rehabilitation.

Adding a fourth column to the SNR loss definitions table, for this you have the following options:

- Insert a checkmark in the "show fourth column" box
- Click on the pencil icon to enter text in the text box
- Click on the dropper icon to add color to the text box



SNR loss definitions

SNR loss	Degree of SNR loss	Expected improvement with directional Mic	Add Column title here.
0-3 dB	Normal / near normal	May hear better than normals in noise	Click on the dropper to add colour.
3-7 dB	Mild SNR loss	May hear almost as well as normals in noise	
7-15 dB	Moderate SNR loss	Directional microphones help. Consider array mic	
>15 dB	Severe SNR loss	Maximum SNR improvement is needed. Consider FM system	

Liste 4 - Result: 0 - Left

Item	Score
0. J'ai beaucoup aimé ce film	
1. Je crois que ton frère est fâché	S/N -18
2. On devrait inviter nos amis plus souvent	S/N -15
3. Viens voir le tableau qu'il a peint	S/N -12
4. Les chevaux galopent dans le pré	S/N -9
5. Ces paquets sont vraiment lourds	S/N -6
6. La vieille femme tombe en riant	S/N -3
7. Tu ont fait le message avant de partir	S/N 0
8. Cette maison est beaucoup trop chère	S/N 3
Total	19.5 - TOTAL = SNR loss

Liste 4 - Result: 5.5 - Right

Item	Score
0. J'ai beaucoup aimé ce film	
1. Je crois que ton frère est fâché	S/N -18
2. On devrait inviter nos amis plus souvent	S/N -15
3. Viens voir le tableau qu'il a peint	S/N -12
4. Les chevaux galopent dans le pré	S/N -9

Examiner: Stanislava

An example of how your fourth column will look in the software once applied.

1.7.3 Finishing the test protocol

Press **OK** in the lower right-hand corner of the AC440 setup screen to save the customized test protocol. The test protocol can then be found in the *Protocols and sessions* dropdown list in the front screen.

Main setup

Protocols
Selected protocol: Joan Jones

Start screen
 Tone Speech MLD Weber SISI HLS MHA QuickSIN

Intensity (tone, speech, SISI)
 Intensity steps: 5 dB
 Default intensity when changing output: 30
 Ch2 start intensity (from OFF -> ON): 15
 Ch2 intensity when changing frequency: Same

Talk forward
 Default talkforward level: 60 dB SPL
 Allow talk fwd in FF
 Talk forward input calibration:

Automatic output selection
 Ch2 opposite ch1 output
 Bone masking: Insert Masking

Pulse
 Multi, pulse length: 500ms
 Single, pulse length: 500ms

Monitor
 Allow monitor on live voice speech

Settings - representation
 Show maximum intensities
 Use BSA logic
 Only show input/output on mouseover

Protocols and sessions
 Joan Jones
 Pediatric FF Speech
 Pediatric FF Tone
 US Adult Speech
 US PT
 US TEN Test
 High Hz
 Joan Jones



1.7.4 Changing a test protocol permanently

You can at any time make changes to an individual test protocol by entering the AC440 setup again as when creating the test.

- 1) Under **Settings** find the test protocol using the *Name* dropdown list.

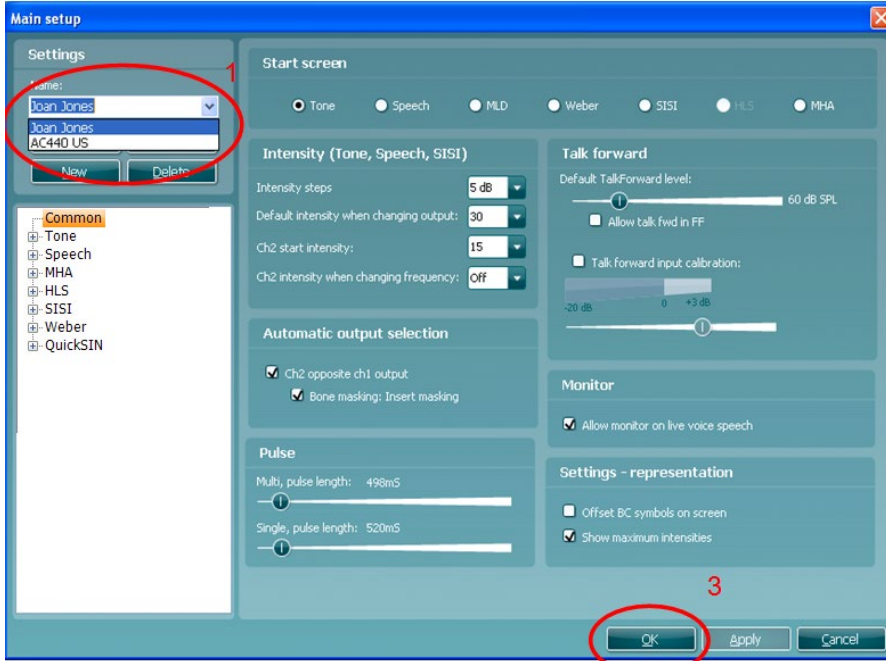

- 2) Browse the setup options as if creating a test protocol (see section 1.6) and amend as desired.
- 3) When finished click **OK** (or **Apply**) to save the changes.

1.7.5 Changing a test protocol temporarily

You may from time to time run into a patient with special needs requiring advanced or different testing parameters. In this situation the *Temporary Setup* can be helpful. The setup changes made here will be specific to the session. The test protocol name will be supplemented with an asterisk (*) to indicate that changes have been made to original test protocol. After saving the protocol will change back to the default selected protocol making you ready for your next patient.



- 1) Enter the *Temporary Setup* by clicking the button in the front screen  (or alternatively select **Menu/Setup/Temporary setup**).
- 2) The Temporary Setup is identical to the AC440 setup. However, functions that cannot be changed temporarily will be greyed out. Browse the setup options to make temporary changes as if creating a test protocol (see section 1.6.2).

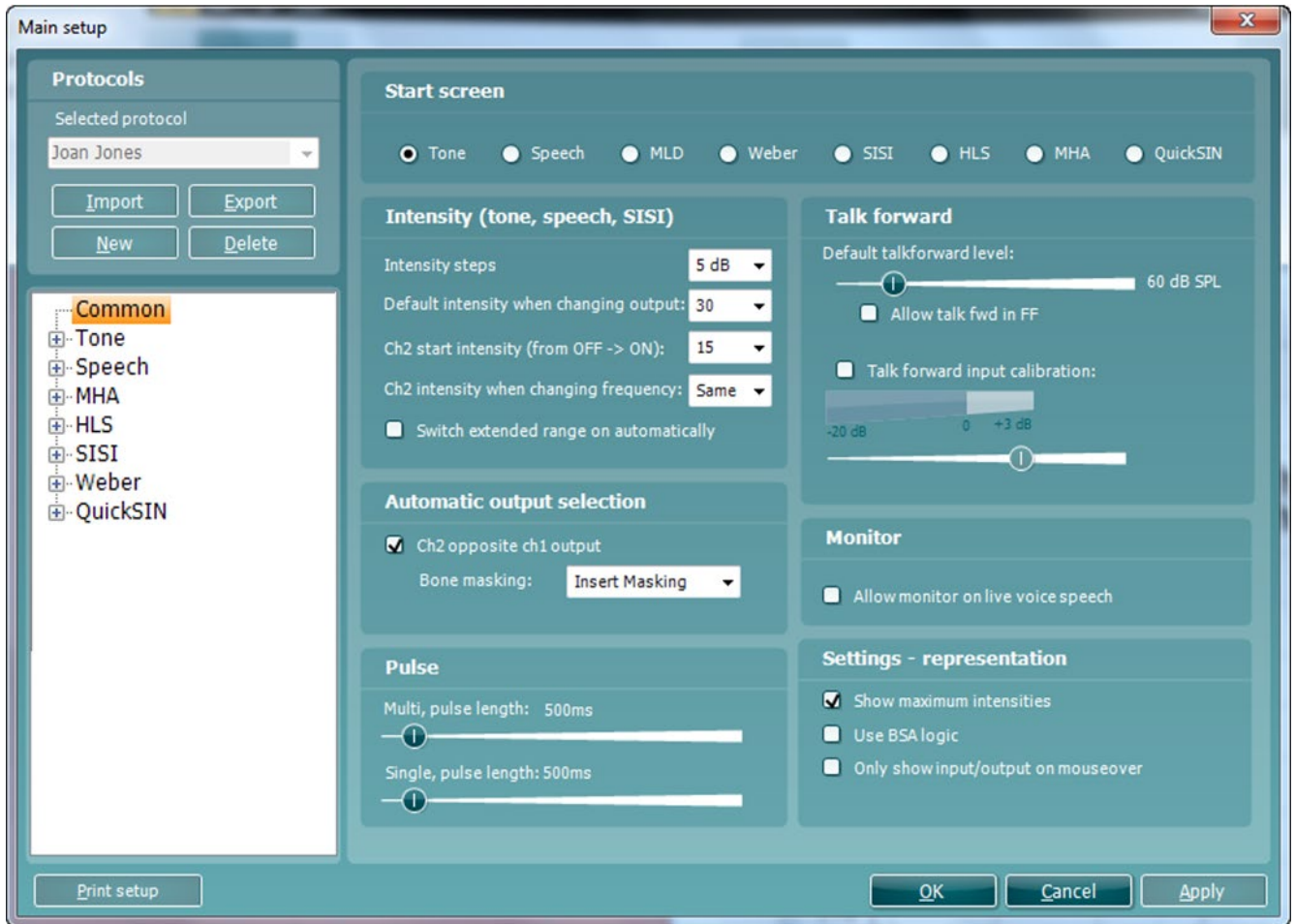

1.7.6 Importing and exporting test protocols

The AC440 also allows you to import and export test protocols to other AC440 users.



1.7.6.1 Importing a test protocol:

- 1) Go to the AC440 Setup (**Menu | Setup | AC440 setup**).

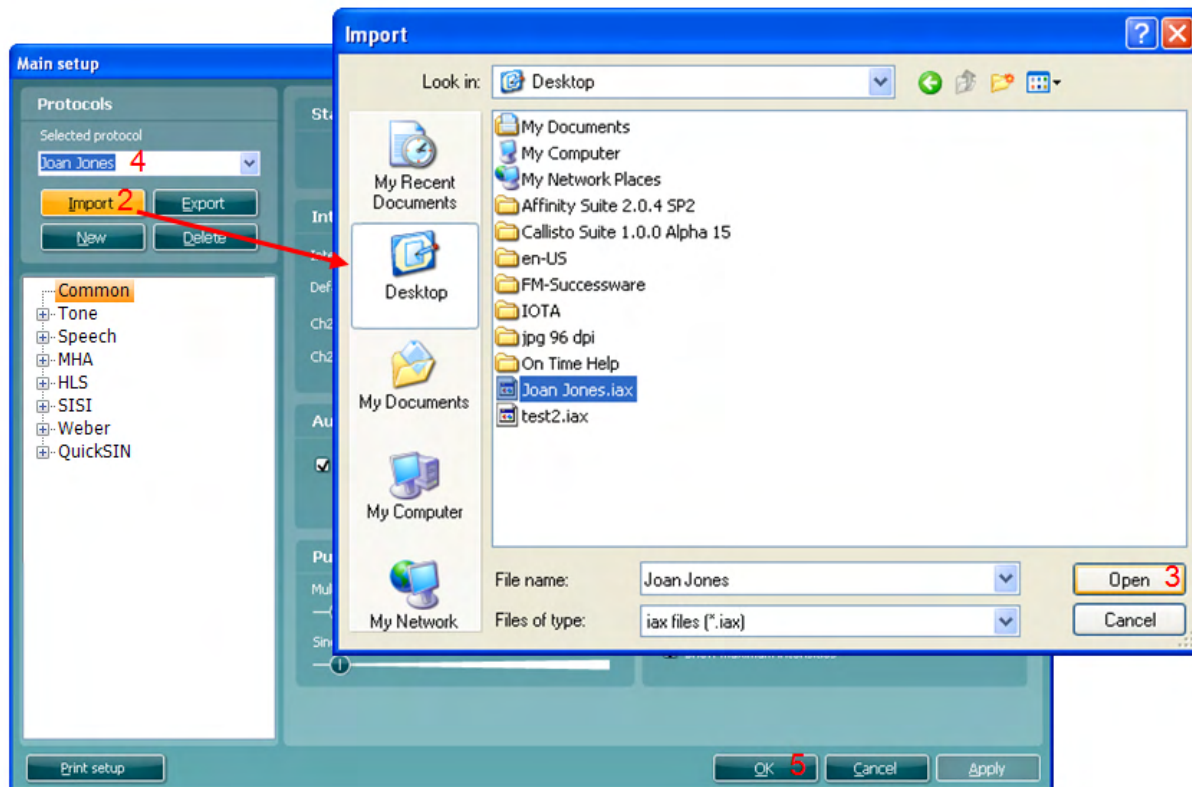

- 2) Click **Import** and browse to the location on the PC or USB where the test protocol file has been saved.
- 3) Click **Open**.
- 4) The test protocol will then appear under **Name**.
- 5) After saving it by clicking **OK** the test protocol can be selected in the *List of defined protocols* in the front screen.

Note that settings of imported protocols cannot be edited if they were exported as “read only”.



1.7.6.2 Exporting a test protocol:

- 1) Go to the AC440 Setup (**Menu | Setup | AC440 setup**).
- 2) Click on **Export**.
- 3) Select if the file is to be saved as “read only”. In this case the protocol file is locked and the clinician receiving it will not be able to make changes to it.

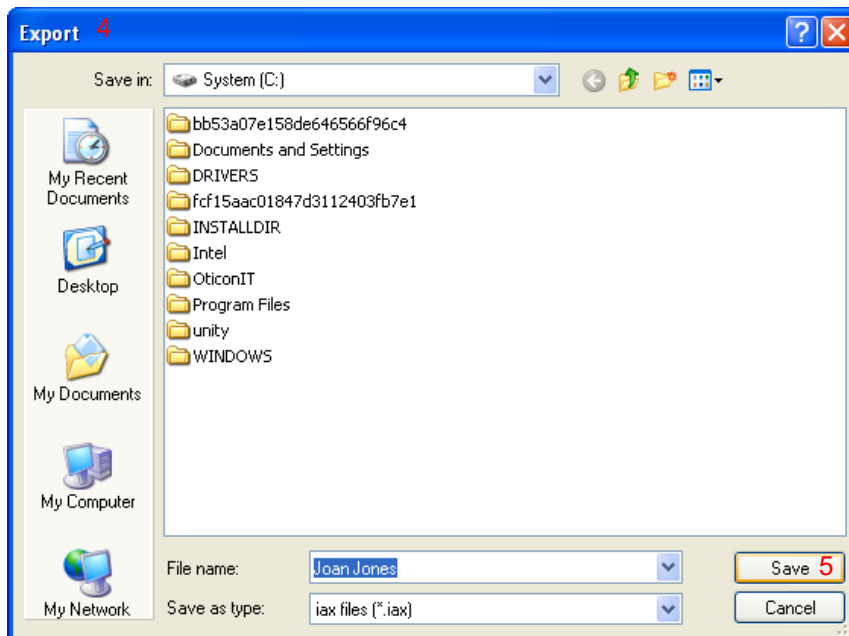
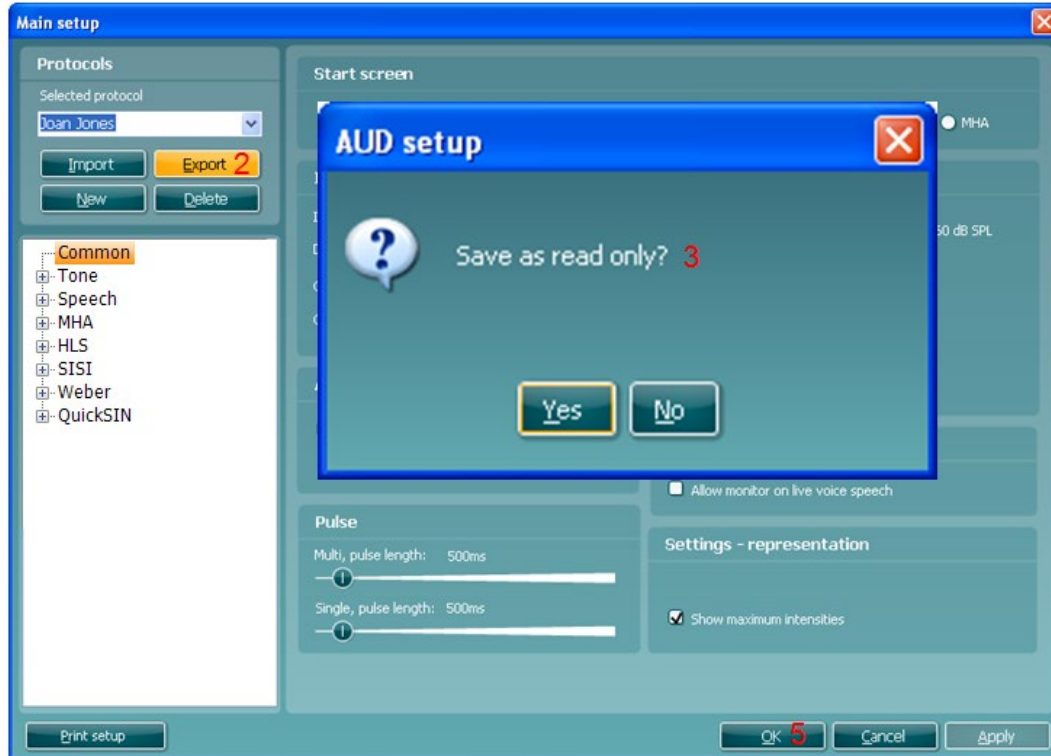

- 4) Browse for the location on the PC or USB where the test protocol is to be placed.
- 5) Click **Save**. Other AC440 users will then be able to upload the test protocol using the Import function.



1.8 General setup

In the *General Setup* you can select overall settings which are valid for all tests and protocols.

To enter the General setup, select **Menu | Setup | General Setup**.

General setup

Symbol scheme

International

Delete Edit New Export Import

NOAH database settings

Use WR1 as SRT measurement (German user scenario)

Save IP measurements as AC

Tone settings

Standard: ANSI

Speech settings

Standard: ANSI Filter mode: Linear

OK Cancel



1.8.1 Symbol editor

You enter the symbol editor by either pressing **Edit** on an existing symbol scheme or by pressing **New** after which you are asked to type a name and select which of the existing symbol schemes is your starting point for the new set.

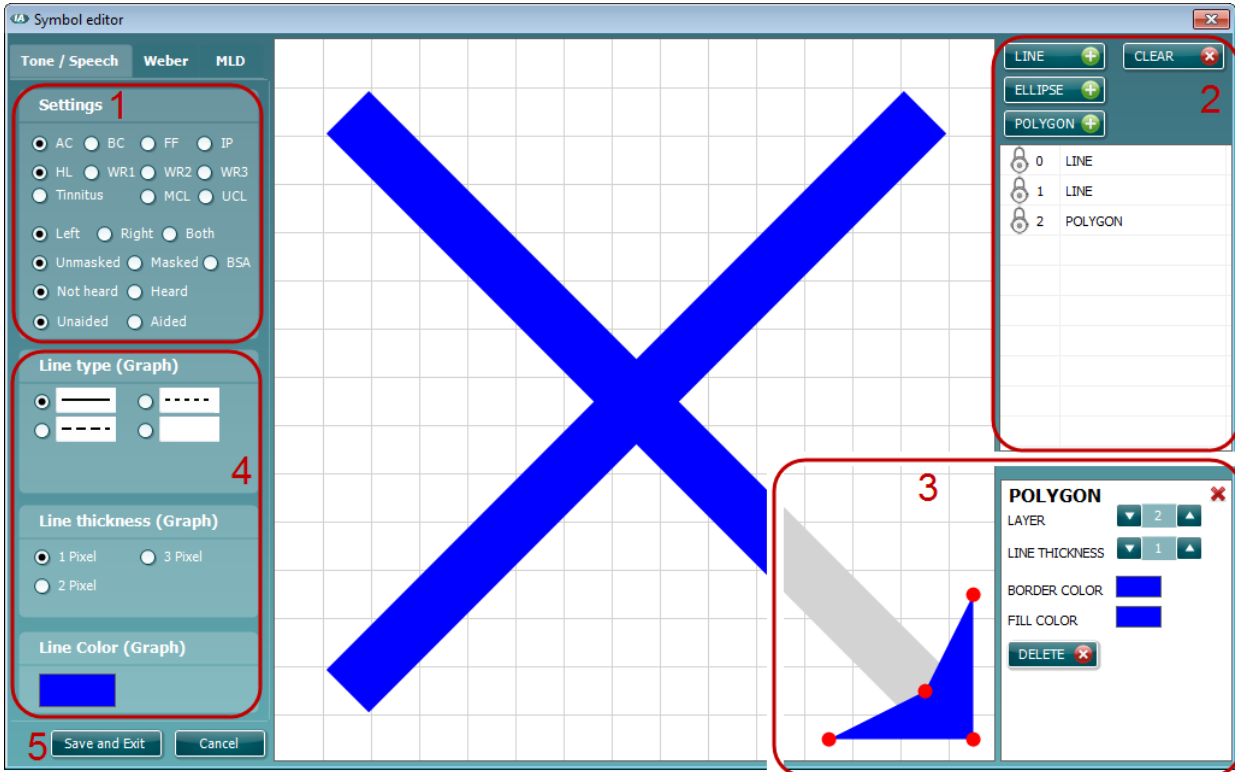

Note: This screen contains three tabs (*Tone/Speech and Weber*).

- 1) Select Tone/Speech, Weber or MLD tab. In the Tone/speech tab each combination of radio buttons stands for an individual symbol. It shows the following groups:
AC, BC, FF, and IP;
HL, WR1, WR2, WR3, Tinnitus, MCL and UCL
Left, Right and Both;
Unmasked, Masked and BSA
Not heard and Heard
Unaided and Aided
- 2) When pressing the **Line**, **Ellipse** or **Polygon** button a new element is added to the current symbol. The existing elements can be clicked for editing as well. Pressing Clear results in removing all elements of the current symbol.
- 3) The element options are shown when an element is selected. Now point with your mouse from where-to-where elements must be placed. Existing elements can be reshaped by dragging the red dots. A line thickness that shows well in the audiogram is thickness 50. The border of filled polygons is never plotted. When done editing an element press the red cross in the top right corner.
- 4) The *Line type*, *Line thickness* and *Line Color* options refer to the lines that connect symbols in an audiogram and apply to the currently shown symbol.
- 5) When done editing all symbols, press **Save and Exit** to store your results. Pressing **Cancel** results in disregarding all changes.



1.8.2 Noah database settings

The option to 'Use WR1 as SRT measurement (German User Scenario)' enables the data to be stored in a specific manner for third party EMR systems to read and display the speech test data as SRT thresholds.

The setting to 'Save IP measurements as AC' allows the user to store all insert earphone measures as standard AC audiometry thresholds. This is useful specifically with some hearing aid fitting softwares which do not read the audiometry when inserts are used.

1.8.3 Tone and speech settings

Select your preferred *Standard* for **Tone settings**. The dropdown list allows you to choose between *ANSI* and *IEC*

Linear	If choosing <i>Linear</i> the system will add filters giving the output of the transducer linear characteristics.
FF equiv.	If choosing <i>FF equiv</i> the system will add filters giving the output of the transducer free field characteristics.
Non-Linear	If choosing <i>Non-linear</i> you omit filters to be able to use a higher intensity for the speech testing. It will enable the system to go as high as 100 dB and if the +20 button  is clicked to 120 dB

- 1) Under **Speech settings** use the dropdown list to choose the desired *Standard*. Choose between *ANSI*, *IEC*, *Sweden*, and *Norway*.
- 2) In *Filter mode* choose the preferred filtering *Linear*, *FF equiv.* (Free Field Equivalent) and *Non-linear*.

Note: If changing the standard for Tone or Speech the AC440 must be re-started. If running under OtoAccess® also re-start the database.



1.9 General suite settings and examiner

In *General suite settings* you find setup items that apply to all modules of the suite. To enter the General Suite settings, enter **Menu | Setup | General suite settings**.

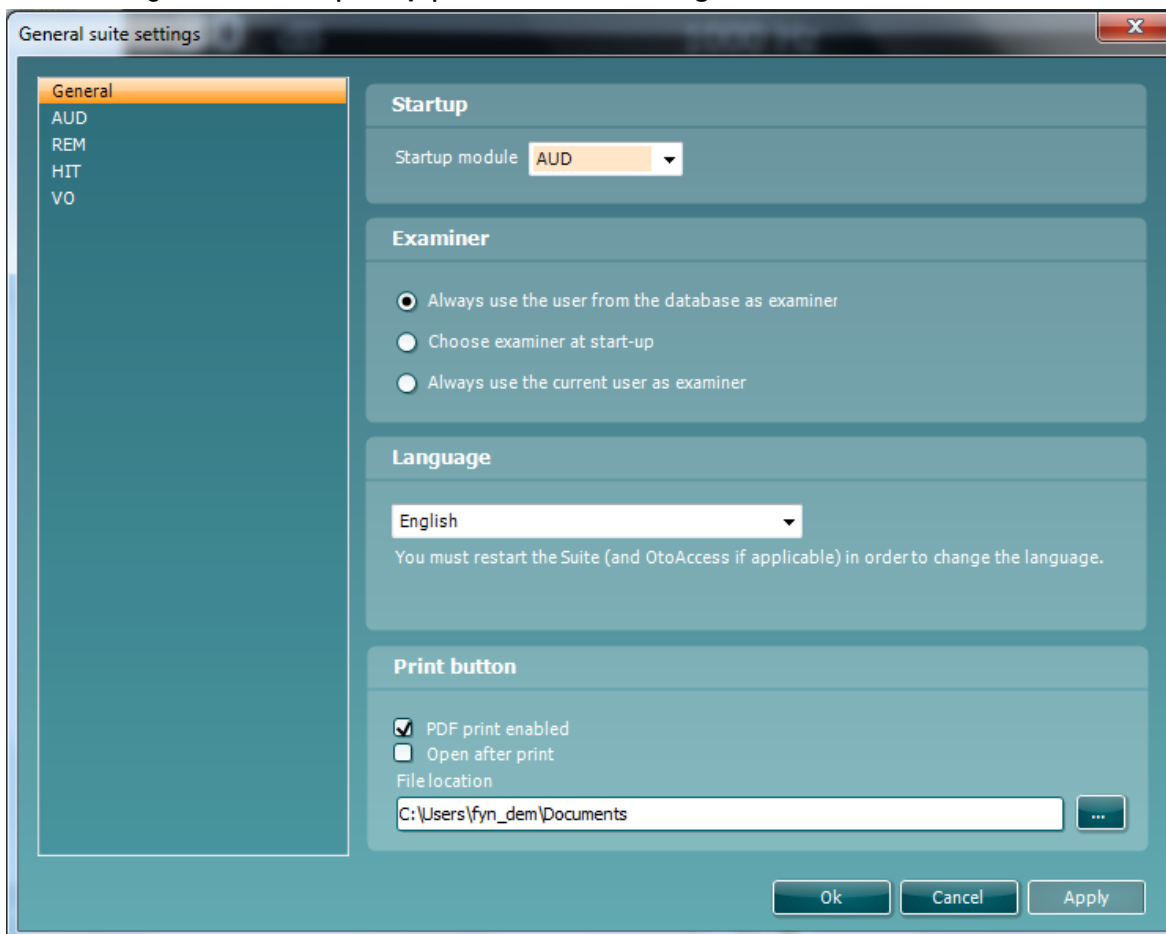

1.9.1 Start-up

Choose which module will be visible on starting up the Suite: AUD, REM, HIT or VO

1.9.2 Examiner settings

At start-up the Suite by default sets the examiner identical to the user of the database through which the Suite was opened. However, when using Noah, you can choose to have the Suite prompting for the current user at start-up. **Note that database traceability features are lost or corrupted** when the examiner in the Suite is chosen different from the database user.

You have the following options:

- Always use the user from the database as examiner
- Choose examiner at start-up
- Always use the current user as examiner.

When choosing *Choose examiner at start-up* the window shown below pops up at start-up. By default, the last examiner is pre-selected.

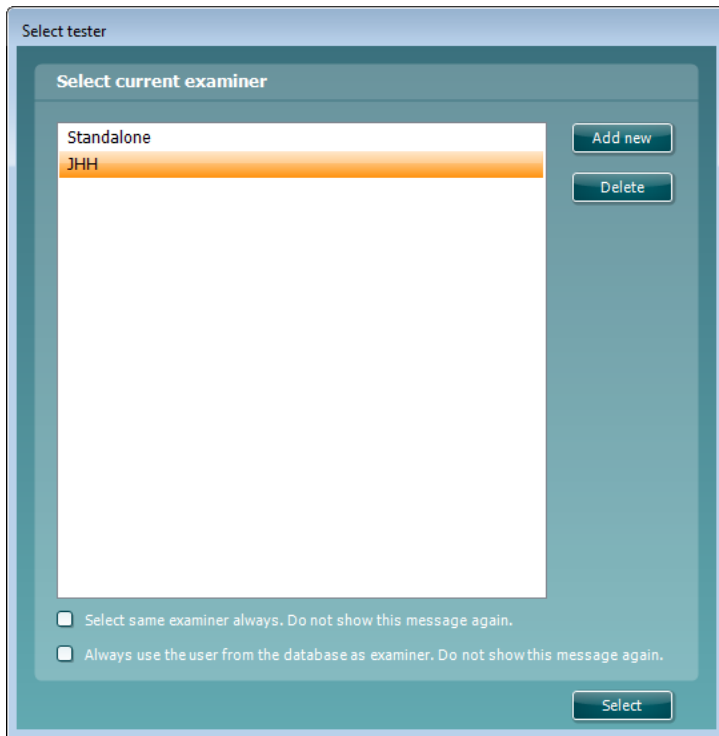

Note that locally, on the pc you are working, for each examiner a log file is created that contains preferences with regards to how the visuals of the Suite are being used. It is remembered which protocol was used last or which protocol is set as default start protocol. Also, the state of items that can be folded or hidden from the user interface are logged for each examiner.

You can print the examiner with your sessions.

1.9.3 Languages

From the drop-down menu, choose the desired language. The available languages within the software are:

- English
- French
- Czech
- German
- Spanish
- Turkish
- Chinese (Peoples Republic of China)
- Finnish
- Italian
- Japanese
- Korean
- Polish
- Portuguese
- Russian
- Greek
- Norwegian
- Swedish
- Dutch



1.9.4 PDF print

The PDF Printing feature has introduced to the Callisto™ and Callisto™ Suites the ability to print to a PDF file on the computer. This is a benefit for paperless documenting of patients test data and for sharing data with people who do not have the Interacoustics Suites. This feature is present for all modules of the Callisto™ and Callisto™ Suites once enabled.

This setting can be enabled via **Menu > Setup > General suite settings**. This will then open the below window:

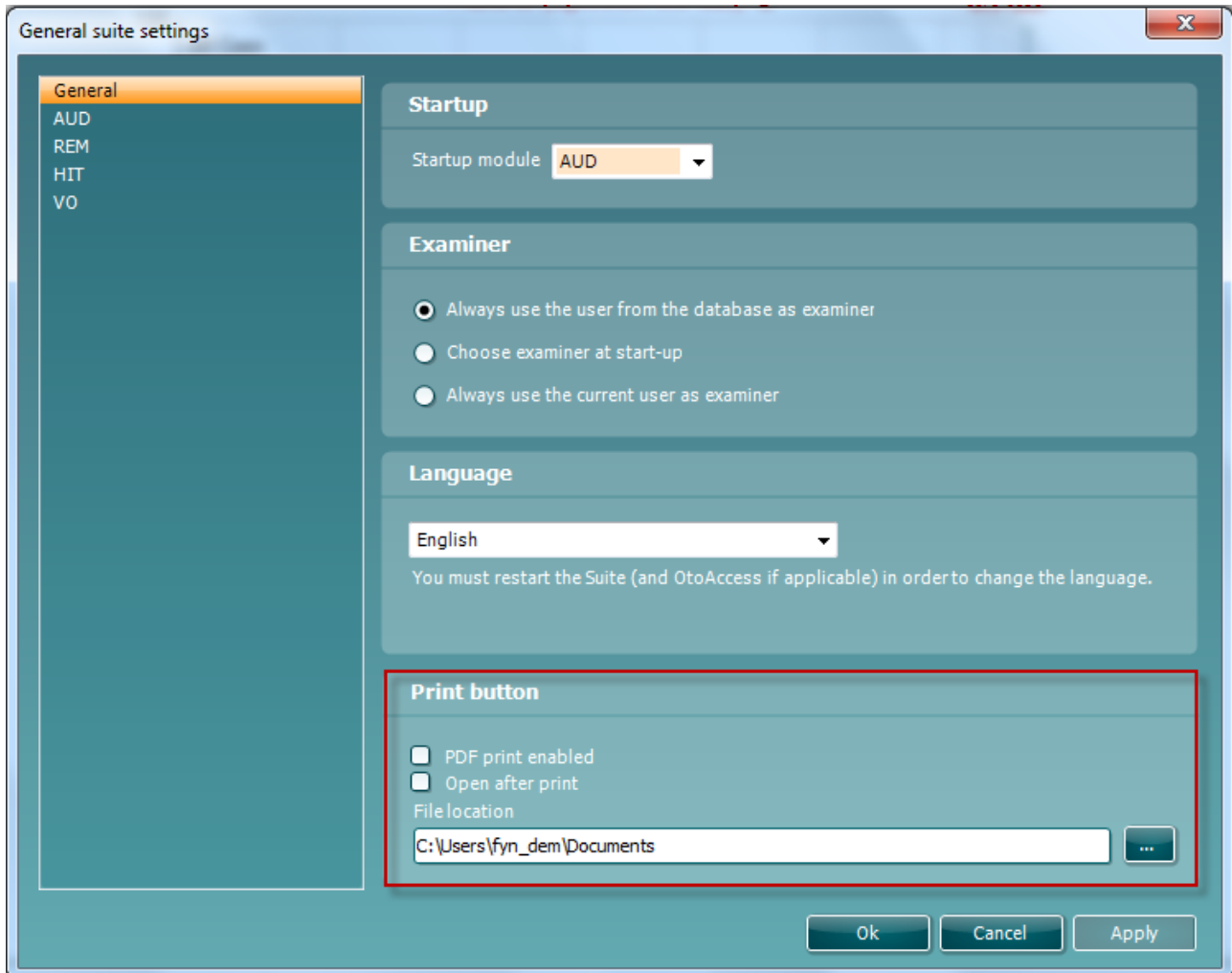

In the bottom section of this window, you can see the settings for the Print button. Checking 'PDF print enabled' will lead to the print button in the Interacoustics suite to change as pictured below

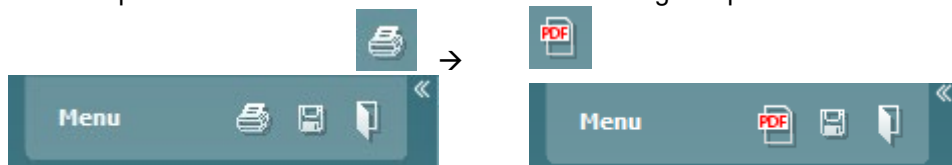

The other setting to 'Open after print' results in the file being opened for viewing once the PDF print button has been pressed.

Finally, in this section you can characterize which file path the PDF printed file is stored.

Note: Should you have PDF print enabled but you wish to print conventionally then you can still perform a physical paper print in the Suite by the following steps Menu > Print > Print.



1.10 Password protection

When password protection is enabled the following menu items are greyed out and thereby make it impossible to permanently change settings.

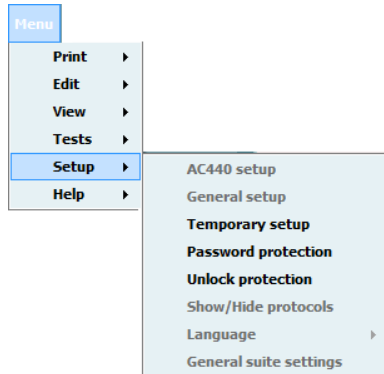

To activate or change a password, select **Menu | Setup | Password protection** and enter and confirm your password. In case no password was used before you must leave current password empty. You remove password protection by leaving the new password empty.

To temporarily disable the password protection, select **Menu | Setup | Unlock protection** and enter your password in the pop-up window.

The password and protection apply to all modules of the suite.



1.11 AC440 menu items

The AC440 Menu gives you access to **Print, Edit, View, Tests, Setup, and Help**.

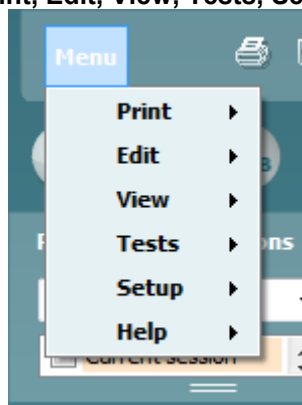

- **Menu | Print | Print** will prompt the system to print using the selected print template (see section **Error! Reference source not found.**)
- **Menu | Print | Print preview** prompts a print preview of the current protocol using the print template which is linked to the current protocol. Note that you are prompted to select a template if the protocol did not include a template (see how to create a print layout in section 4.1.1)
- **Menu | Print | Print layout** opens the print wizard window from where you can select or create a template to print the current protocol (see section for details regarding the Print Wizard **Error! Reference source not found.**).
- **Menu | Edit | Transfer to current session** will move a currently viewed historical audiogram to the current session.
- **Menu | Edit | Export** will prompt the system to export the session as an XML formatted file.
- **Menu | Edit | Swap audiometric data from ears** allows you to swap data from right to left and left to right for the current test only.
- **Menu | View | Reset visual settings** sets all user interface settings back to default (as they appear for a new user).
- **Menu | View | Save current window position** saves the position of the AC440 window on the PC screen so that it will open at this exact position every time. This is for example practical if the running other software modules at the same time.
- **Menu | Tests | Tone** opens the Tone test
- **Menu | Tests | Speech** opens the Speech test
- **Menu | Tests | Weber** opens the Weber test
- **Menu | Tests | SISI** opens the SISI test²²
- **Menu | Tests | MHA** opens the MHA screen²³
- **Menu | Tests | HLS** opens the HLS screen²⁴
- **Menu | Tests | QuickSIN** opens the QuickSIN test²⁵
- **Menu | Setup | AC440 setup** opens the AC440 where you can setup customised test protocols (see section 1.6 for details)
- **Menu | Setup | General setup** opens the General setup where settings valid for all tests can be selected (see section 1.7 for details)
- **Menu | Setup | Temporary setup** opens the Temporary setup where temporary settings for the specific session can be selected (see section 1.6.5 for details)
- **Menu | Setup | Password protection** allows you create or change a password and thereby protect your AC440 settings (see section 1.9).
- **Menu | Setup | Unlock protection** allows you temporarily disabling password protection (see section 1.9).
- **Menu | Setup | Show/hide protocols** prompts a screen allowing you to tick test protocols which are to be shown in the *List of defined protocols* and untick the test protocols which are to be hidden.

²² The SISI test requires an additional software license.

²³ MHA requires an additional software license.

²⁴ HLS requires an additional software license.

²⁵ QuickSIN requires an additional software license.



- **Menu | Setup | Language** opens the language selection. Choose from *English, Finnish, German, Czech, Korean, Spanish, French, Turkish, Italian, Japanese, Polish, Portuguese, and Chinese (People's Republic of China)*. The system must be restarted for a new language selection to take effect.
- **Menu | Setup | General suite settings** opens the General suite settings in which items are found that apply to all modules (see section 1.8).
- **Menu | Setup | Operator sound settings** opens the Operator sound settings allowing you to change talk forward and talk back settings, without the need of having these permanently locked within the protocol
- **PC Shortcut Keys** opens the PC shortcut manager, where the clinician can customize PC shortcuts from the default if desired.
- **Menu | Help | About AC440** prompts a message box showing information regarding *Suite version, Hardware version, and Firmware version*. Please note that if experiencing problems with the system this information should be send to the manufacturer along with the description of the issue.

Note: Press **License** to be able to type in a new license code.



1.12 PC shortcut manager

The PC Shortcut Manager allows the user to personalize PC keyboard shortcuts in the AC440 Module. To access the PC Shortcut Manager go to **Menu | Setup | PC Shortcut Keys** in the AUD module. It can also be accessed by pressing **Ctrl + Alt + Shift + S** simultaneously when in the AUD module of the software.

To view the default shortcuts, click on the items in the left-hand column

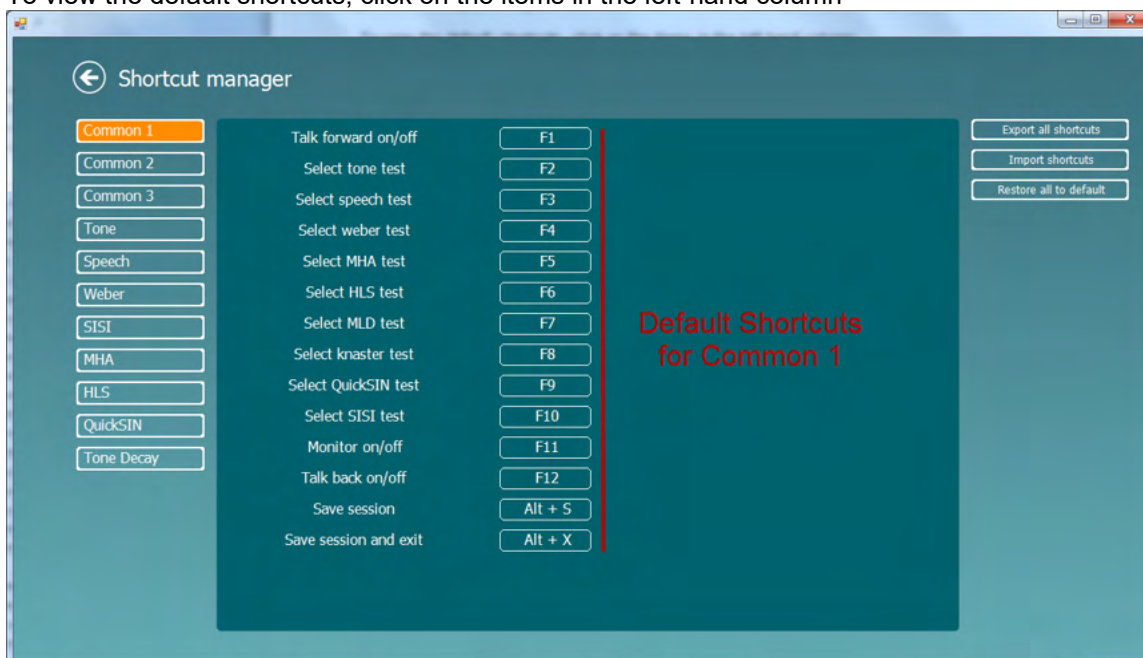

To personalize a shortcut, click on the column in the middle and add the custom shortcut in the field on the right hand of the screen

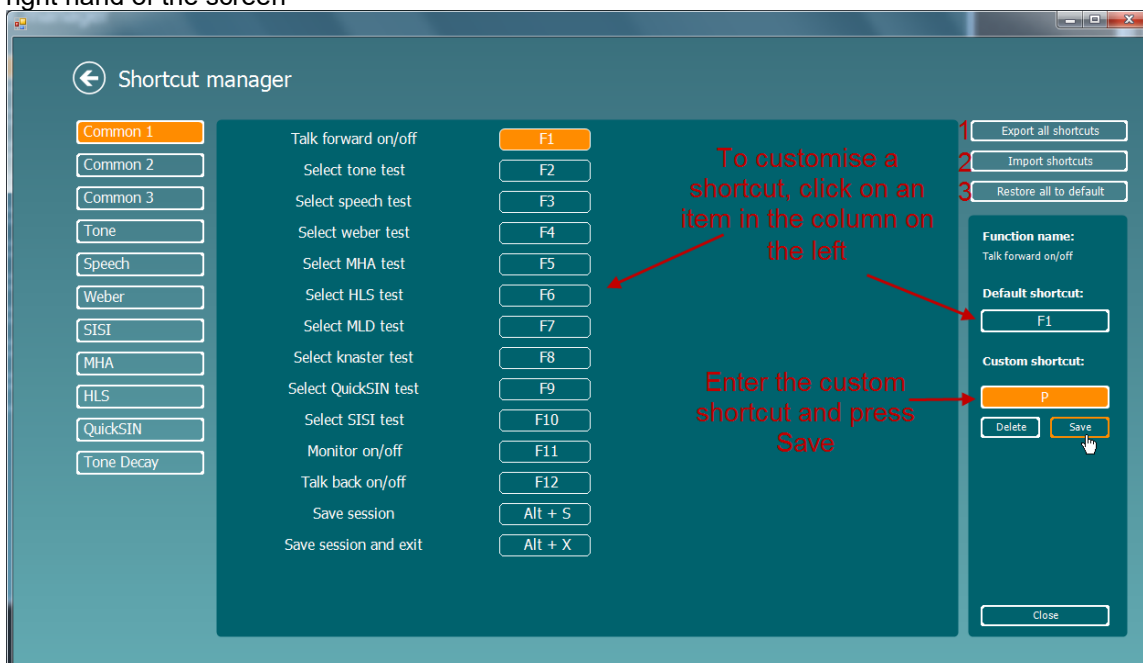

- 1) Export all shortcuts: Use this function to save custom shortcuts and transfer them to another computer
- 2) Import shortcuts: Use this function to import shortcuts that have already been exported from another computer
- 3) Restore all defaults: Use this function to restore the Factory Settings default



1.13 Standalone database settings

We have made it possible for the user to change the location for the standalone data to be stored. This has been a request to improve the security of the information stored so that data isn't stored locally but to a network drive.

This can be changed by going to the following location, C:\Program Files (x86)\Interacoustics\Callisto™ Suite, and launching the application titled FolderSetupCallisto™.exe. On doing this the below window will be shown.

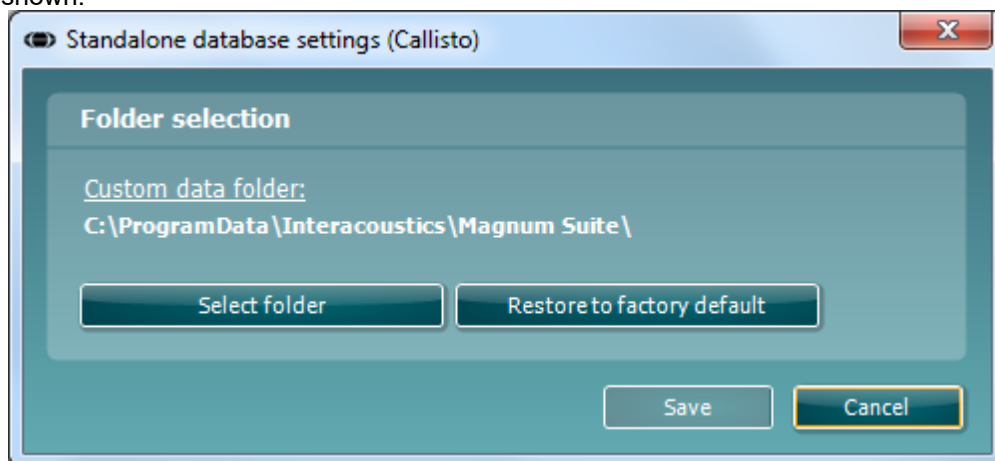

This allows you two options:

On pressing 'Select folder' the windows system dialogue is opened where you can choose the custom location where you would like for your data to be stored.

On pressing 'Restore to factory default' any custom changes to the folder made in the previous 'Select folder' option can be reverted to the default.

After making any changes the 'Save' button will light up giving you the option to apply your changes.

1.14 View data without license

The Affinity Suite has the ability to allow you to view and review data on a system which is not fully licensed without disconnecting your device. As an example, should your Callisto not be licensed for REM, you can still see the REM data performed via another system in the same suite.

When this happens the module which is unlicensed will show in a view mode, this is reflected in the session browser. An example of this is shown below.

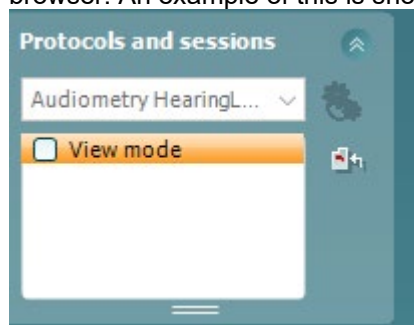

In the Audiometry Test list there will be a list of the tests which are unlicensed with a hover note 'Only view mode', to indicate when a test is unlicensed in your system but will still allow you access to that test screen.

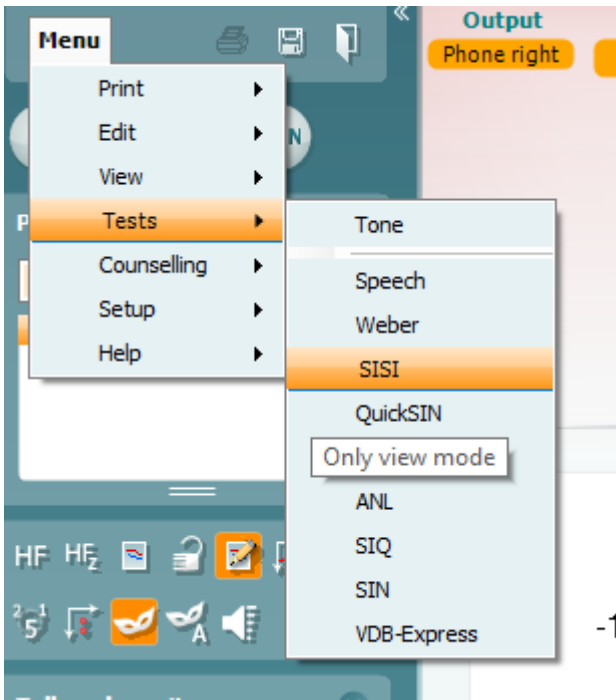

-1

When you enter a test which is unavailable the HUD will be completely greyed out and the data is only permitted to be viewed and not interacted with.



1.15 FAQ

When I open my AC440 a screen appears saying that my hardware is not connected. What could be the cause of this?

Ensure that the Callisto™ hardware is connected properly. This will be indicated by the picture of the instrument in the lower left corner of the screen. Check both the power cable and the USB connection. Also check for the light indicating that the instrument is switched on.

If you have not been connected to the device before, ensure that you run the New Hardware Found wizard that installs the USB driver.

Some functions are greyed out in my AC440 module. How can I use these?

Functions greyed out can be caused by more than one factor. Some functions require a special licence such as *High Frequency* and *Multi Frequency* testing. If the licence is not purchased the functions are greyed out. Other functions may be greyed out due to the current setting.

My test has locked. I cannot present any tones – why could that be?

Please check that you are not in *Edit mode*. When *Edit mode* is active no testing can be performed.

Deactivate *Edit mode*, , to continue. Another reason for this problem could be because you are not in the current session, please click on 'Current Session' in the session browser to continue.

Can I change my settings for one session only?

Yes, this is done in the *Temporary Setup* .

Changes made here will automatically disappear when saving or closing the session. Notice that functions that cannot be changed temporarily will be greyed out.

Can I delete a point or make changes to my audiogram?

The current audiogram can be edited using right mouse click in the audiogram or via the 'Edit Mode'.

Previously saved audiograms cannot be edited in this manner, and you will need to transfer an old session to the current one via the **Menu | Edit | Transfer to current session**.

How do I insert a no response?

This can be done in three ways:

- 1) Press "N" on the PC keyboard.
- 2) If using the dedicated audiometry keyboard, hold down the "store" button for approximately 2 seconds.
- 3) Right click on the point of no response in the curve and choose *Add no response*.
- 4)

How do I get my masking level on the audiogram?

This is done in the AC440 setup. Select **Menu | Setup | AC440 setup** followed by *Tone, Common*. Ensure that Store masking information on screen is ticked.

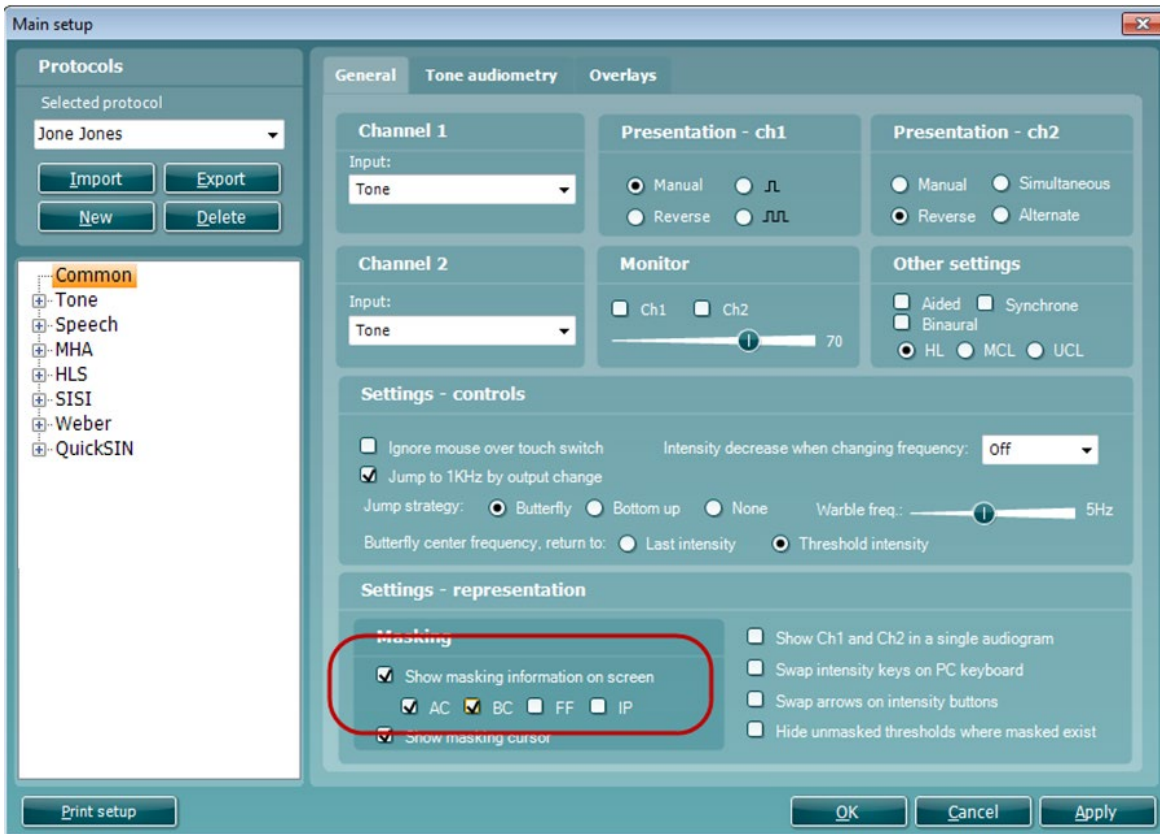

Can I upload my own speech material?

Yes, but a special tool is needed for this. Contact Interacoustics or the local distributor to acquire this software (see section Appendix 1 for a description of the indexing process). You will need to have purchased the Speech from Hard Drive (SFH440) license to use wave file materials.



1.16 Appendix 1

1.16.1 Audiometer implementation of the TEN(HL) test for diagnosing cochlear dead regions

By Brian C.J. Moore, Ph.D.

Until recently, the TEN(HL) test for diagnosing dead regions in the cochlea could only be conducted by use of a compact disc player connected to an audiometer. Now, the test has been implemented within the Callisto™ and Equinox^{2.0} PC-based audiometers (version 2.0.4) made by Interacoustics. This article describes: (1) What is meant by a dead region in the cochlea; (2) The basis of the TEN(HL) test for diagnosing dead regions in the cochlea; (3) The implementation of the TEN(HL) test in the Interacoustics audiometers; (4) The clinical value of diagnosing dead regions.

What is a dead region?

Sounds entering the ear give rise to vibration patterns on the basilar membrane within the cochlea. Each place on the basilar membrane is tuned to respond best to a specific small range of frequencies; high-frequency sounds produce maximum vibration towards the base and low-frequency sounds produce maximal vibration towards the apex. The frequency that leads to a maximal vibration at a given place on the basilar membrane is called the characteristic frequency (CF) for that place. In an ear with normal hearing, the patterns of vibration on the basilar membrane are strongly influenced by the activity of the outer hair cells (OHCs), which are minute sensory cells forming rows along the length of the basilar membrane. The OHCs play a role in what is called the “active mechanism” in the cochlea.¹ They do this by changing their stiffness and length in response to the vibrations on the basilar membrane. This activity of the OHCs enhances the response to weak sounds (increasing the amplitude of vibration) and sharpens the tuning on the basilar membrane. This sharpening increases the frequency selectivity of the auditory system, i.e., its ability to separate out the different frequencies that are present in complex sounds such as speech and music. The amplified vibrations are then detected by the inner hair cells (IHCs), which form a single row running along the length of the basilar membrane. In response to vibrations on the basilar membrane, the IHCs release neurotransmitter, and this leads to neural activity in the auditory nerve.

Cochlear hearing loss is often associated with damage to the hair cells within the cochlea.^{1,2} This damage can give rise to raised hearing thresholds (i.e., hearing loss as measured by the audiogram) in two main ways. Firstly, damage to the OHCs impairs the active mechanism in the cochlea, resulting in reduced basilar-membrane vibration for a given low sound level.³ Hence, the sound level must be larger than normal to give a just-detectable amount of vibration. Secondly, IHC damage can result in less efficient stimulation of the auditory nerve. As a result, the amount of basilar membrane vibration needed to reach the hearing threshold is larger than normal.⁴ A cochlear hearing loss up to about 55 dB may be caused by damage to OHCs alone. A hearing loss greater than 55 dB nearly always involves some loss of function of IHCs as well as OHCs.² From measurement of the audiogram alone, it is not possible to determine what proportion of the hearing loss is due to OHC damage and what proportion to IHC damage.

In some cases, the IHCs at certain places along the basilar membrane may be completely non-functioning. In addition, the auditory neurons contacting those places may be non-functioning. Places with non-functioning IHCs and/or neurons have been referred to as “lacunae”⁵ and “holes in hearing”⁶, but I have used the blunt phrase “dead regions”⁷⁻¹⁰ and that phrase seems to have caught on, although the phrase “dead zones” is also quite common. Figure 1 shows the dissected cochlea of a person who had been exposed to intense impact sounds (gunshots) before dying in an incident unrelated to gunshots! The dark lines are the neurons that would eventually get together and form the auditory nerve. There are essentially no neurons coming from the basal part of the cochlea, indicating a high-frequency dead region.



Basilar-membrane vibration that occurs within a dead region cannot be detected by the neurons connected to that region (if there are any). Say, for example, that the IHCs at the basal (high frequency) end of the cochlea are non-functioning. Neurons connected to the basal end, that would normally have high CFs, will not respond. However, if a high-frequency pure tone is presented, it may be detected if it produces sufficient basilar-membrane vibration at a region closer to the low-frequency, apical end. In other words, a high-frequency sound may be detected via neurons that are tuned to lower frequencies. This is sometimes called “off-place listening” or “off-frequency listening”. Similarly, if there are no functioning IHCs in an apical region of the cochlea, a low-frequency tone may be detected via neurons that are tuned to higher frequencies.

Because of this possibility, the “true” hearing loss at a given frequency may be greater than suggested by the audiometric threshold at that frequency. Also, for this reason, dead regions are not easy to diagnose from the pure-tone audiogram, although a hearing loss greater than 70 dB is often associated with a dead region.^{11,12}

A dead region can be characterised in terms of the range of CFs that would normally be associated with that region. In other words, a frequency-to-place map is used to relate the cochlear location at each edge of the dead region to frequency. This is illustrated in Figure 2. Say, for example, that the IHCs are non-functioning over a region of the basilar membrane having CFs in the range 2500 to 20000 Hz. One might describe this as a dead region extending from 2500 Hz upwards. The lower “edge frequency” of the dead region in this example is 2500 Hz. Henceforth, the edge frequency is denoted f_e .

The TEN(HL) test for diagnosing dead regions in the cochlea

The TEN(HL) test for diagnosing dead regions was designed to be quick and easy to administer and hence suitable for use in clinical practice. The development and validation of the first version of the test are described in Moore *et al.*⁸ The test involves measuring the threshold for detecting a pure tone presented in a background noise called “threshold-equalizing noise” (TEN). Therefore, the test is called the TEN test. The noise was synthesised in such a way that the threshold for detecting a tone in the noise, specified in dB SPL, was approximately the same for all tone frequencies in the range 0.25 to 10 kHz, for people with normal hearing. The masked threshold is approximately equal to the nominal level of the noise specified in dB SPL.

When the pure-tone signal frequency falls in a dead region, the signal will only be detected when it produces sufficient basilar-membrane vibration at a remote region in the cochlea where there are surviving IHCs and neurons. The amount of vibration produced by the tone at this remote region will be less than in the dead region, and so the noise will be very effective in masking it. Thus, the signal threshold is expected to be markedly higher than normal. Moore *et al.*⁸ proposed the following rule: a dead region at a particular frequency is indicated by a masked threshold that is at least 10 dB above the absolute threshold **and** 10 dB above the nominal noise level.

To make the test easy to administer, the TEN test was recorded on a CD; the noise was on one channel and test tones were on the other channel. For this implementation of the test, the signals from the CD were fed through a two-channel audiometer. The methods used to conduct the test were like those used for conventional pure-tone audiometry, except that the signal threshold was measured in the presence of a continuous background noise.

A problem with the first version of the TEN test was that the clinician had to measure absolute thresholds (audiometric thresholds) twice, once using the tones generated by the audiometer, with level specified in dB HL, and once using the tones from the CD, with level specified in dB SPL. This was inconvenient for the clinician. To overcome this problem, a second version of the TEN test was developed in which the noise was designed to give equal masked thresholds in dB HL for all frequencies from 500 to 4000 Hz, for normally hearing people.¹³ This version is called the “TEN(HL)” test. As all calibrations were in dB HL, absolute thresholds could be measured either using the tones generated by the audiometer or using the test tones from the CD; the results were expected to be very similar. However, the TEN(HL) test can only be used with specific headphones; with the current version of the test, suitable headphones are TDH39, TDH 49 and TDH50.



Another advantage of the second version of the test is that the noise has been designed to have minimal amplitude fluctuations; such noise is called “low-noise noise”.¹⁴ Figure 3 shows the spectrum of the noise (top) and a sample of the waveform (bottom). Note that all peaks and dips in the waveform are of similar magnitude. This characteristic allows high noise levels to be used without significant distortion being produced by the audiometer or earphone. Hence, testing is possible for more severe hearing losses than could be assessed with the earlier version, without any special equipment being required.

The criteria for diagnosing a dead region are like those for the earlier test: a dead region at a particular frequency is indicated by a masked threshold that is at least 10 dB above the absolute threshold **and** 10 dB above the nominal noise level in dB HL.

Implementation of the TEN(HL) Test in Interacoustics audiometers

The implementation of the TEN(HL) test in the Callisto™ and Equinox^{2.0} PC-based Interacoustics audiometers makes it easy and simple to administer the TEN(HL) test. There is no need to have any equipment external to the audiometer. A pre-defined setup for performing the TEN(HL) test can be selected from a drop-down menu of “User protocols”. One ear at a time is tested, and on-screen boxes are used to determine whether the TEN plus test tone are delivered to the right ear or the left ear. Possible frequencies for the test tone are 500, 750, 1000, 1500, 2000, 3000 and 4000 Hz.

The level of the TEN in dB HL can be set using the computer mouse, by clicking the appropriate point on the screen, or by using the appropriate knob on the optional dedicated keyboard. Initially, the TEN is turned off while the appropriate level is selected. Some useful rules for selecting the level of the TEN are as follows:

- 1) For frequencies where the hearing loss is less than or equal to 60 dB, set the TEN level to 70 dB. This is not unpleasantly loud for most people, and it leads to a definitive result.
- 2) When the hearing loss is 70 dB or more at a given frequency, set the TEN level 10 dB above the audiometric threshold at that frequency. For example, if the audiometric threshold is 75 dB HL, set the TEN level to 85 dB HL.
- 3) If the TEN is found to be unpleasantly loud, or if the maximum TEN level of 90 dB HL is reached, then the TEN level can be set equal to the audiometric threshold. This should still give a definitive result.

It may be difficult or impossible to apply the TEN(HL) test when the hearing loss at the test frequency is 90 dB or more, although it is quite likely that a dead region would be present with such a severe hearing loss. Note that the TEN level does not need to be the same for all test frequencies. Once the level is chosen for a given test frequency, the TEN is turned on continuously, by placing the cursor over “stimulus” or by clicking on “Rev”.

The threshold for detecting a test signal in the TEN is determined using the same procedure as would be used for manual audiometry, except that a step size in level of 2 dB should be used when the tone is in the region of the detection threshold; larger steps can be used initially, to find the approximate threshold. 2-dB steps are automatically selected when the TEN(HL) test is chosen from the drop-down menu. The use of small steps makes the outcome more precise, and reduces the incidence of false positives.¹⁵ Once the threshold has been measured for a given test frequency, the appropriate TEN level is set for the next test frequency, and the process is repeated.

For a person with normal hearing, the threshold of the test tone in the TEN is typically equal to the TEN level. For example, if the TEN level is set to 70 dB HL, the threshold for detecting the test tone is about 70 dB HL, for any frequency from 500 to 4000 Hz. If a patient has a cochlear hearing loss but does not have a dead region at the test frequency, then the threshold of the test tone in the TEN is typically a few dB above the TEN level. For example, if the TEN level is set to 70 dB HL, the threshold for detecting the test tone might be 73 dB HL. However, when the test tone frequency falls in a dead region, the threshold for detecting the test tone in the TEN is typically well above the TEN level. The criteria for diagnosing a dead region at a specific frequency are:



- 1) The threshold of the test tone in the TEN is 10 dB or more above the TEN level.
- 2) The threshold of the test tone in the TEN is 10 dB or more above the audiometric (absolute) threshold. If the TEN level is selected as described earlier, then criterion 2) will automatically be satisfied when criterion 1) is satisfied.

Figure 4 is a screen shot from the Callisto™ system, showing audiometric thresholds (circles) and TEN(HL)-test results (“TEN” symbols) for a person with good low-frequency hearing but a severe high-frequency hearing loss. The results suggest that this patient has a dead region extending upwards from 1.5 kHz.

It typically takes about 4 minutes per ear to perform the TEN(HL) test for all test frequencies. In practice, it is usually not necessary to conduct the TEN(HL) test for frequencies where the hearing loss is 50 dB or less. For example, if a patient has a typical sloping hearing loss, with relatively good hearing at low frequencies and poor hearing at high frequencies, it is only necessary to conduct the test for the medium and high frequencies. However, if the patient has an unusually shaped audiogram, such as a localized mid-frequency loss, it may be worth conducting the TEN(HL) test even when the loss is mild.

Clinical applications of the TEN(HL) test

The presence or absence of dead regions can have important implications for fitting hearing aids and for predicting the likely benefit of hearing aids. When a patient has a dead region, there may be little or no benefit in applying amplification (via a hearing aid) for frequencies well inside the dead region. However, for patients with high-frequency dead regions, there may be some benefit in applying amplification for frequencies up to about $1.7f_e$.^{16,17} For example, if a patient has a dead region which starts at 1000 Hz and extends upwards from there, there may be some benefit in amplifying frequencies up to 1700 Hz. However, there will probably be no benefit of applying amplification for frequencies above about 1700 Hz. Trying to achieve sufficient gain for frequencies above 1700 Hz might lead to problems with distortion and acoustic feedback. For a patient with an extensive high-frequency dead region, a hearing aid incorporating frequency transposition or frequency compression might be a viable option.^{18,19}

For people with low-frequency dead regions, as can occur, for example, in cases of Meniere’s syndrome, there appears to be some benefit of amplifying frequencies above $0.57f_e$, but not of amplifying frequencies below $0.57f_e$.^{20,21} Amplification of frequencies below $0.57f_e$ can actually lead to reduced speech intelligibility.

In rare cases, the audiogram may have the form of an inverted V; hearing is relatively good over a small frequency range, and poor at all remaining frequencies. This can indicate a restricted functioning region in the cochlea, with extensive dead regions below and above it.²²⁻²⁴ However, it is not safe to make a diagnosis of dead regions based solely on an inverted V-shaped audiogram²³; a test such as the TEN(HL) test is needed for a firm diagnosis. For a patient who does have a restricted functioning region, with dead regions above and below the functioning region, the most effective amplification strategy may be to amplify over a limited frequency range around the functioning region.²⁴

The TEN(HL) test may also be relevant for patients who are being considered for a cochlear implant; a patient with very extensive dead regions would be likely to do better with a cochlear implant than with a hearing aid (or aids). The test may also be useful for patients who are being considered for a combination of a cochlear implant and a hearing aid. Such patients typically have a dead region in the parts of the cochlea that normally respond to medium and high frequencies but have some functional hearing at lower frequencies. It may be useful to determine the edge frequency, f_e , of any dead region. This may be relevant to choosing the most appropriate insertion depth of the electrode array, and to the way that frequencies in the input signal are mapped to acoustic and electric stimulation.²⁵



The clinician needs to be alert for some special cases. Patients with auditory neuropathy sometimes have high thresholds for detecting the test tone in the TEN, meeting the TEN(HL) test criteria for diagnosis of a dead region, even for frequencies where their audiometric thresholds are near normal.²⁶ This does not necessarily indicate that they have extensive dead regions, although they may have only patchy survival of IHCs.²⁷ Patients may also have high thresholds for detecting the test tone in the TEN as a result of central problems, for example brain injury in auditory areas resulting from trauma or a stroke.²⁸ These high thresholds may result from poor “detection efficiency” rather than from dead regions. Nevertheless, high thresholds in the TEN are likely in all cases to be associated with a poor ability to understand speech when background sounds are present.



References

1. Moore BCJ, *Cochlear Hearing Loss: Physiological, Psychological and Technical Issues, 2nd Ed.*, Chichester: Wiley; 2007.
2. Schuknecht HF, *Pathology of the Ear, 2nd Ed.*, Philadelphia: Lea and Febiger; 1993.
3. Ruggero MA, Rich NC. Furosemide alters organ of Corti mechanics: Evidence for feedback of outer hair cells upon the basilar membrane. *J. Neurosci.* 1991; 11: 1057-1067.
4. Liberman MC, Dodds LW. Single neuron labeling and chronic cochlea pathology. III. Stereocilia damage and alterations in threshold tuning curves. *Hear. Res.* 1984; 16: 54-74.
5. Troland LT. The psychophysiology of auditory qualities and attributes. *J. Gen. Psych.* 1929; 2: 28-58.
6. Shannon RV, Galvin JJ, 3rd, Baskent D. Holes in hearing. *J. Assoc. Res. Otolaryngol.* 2002; 3: 185-199.
7. Moore BCJ, Glasberg BR. A model of loudness perception applied to cochlear hearing loss. *Auditory Neurosci.* 1997; 3: 289-311.
8. Moore BCJ, Huss M, Vickers DA, Glasberg BR, Alcántara JI. A test for the diagnosis of dead regions in the cochlea. *Br. J. Audiol.* 2000; 34: 205-224.
9. Moore BCJ. Dead regions in the cochlea: Diagnosis, perceptual consequences, and implications for the fitting of hearing aids. *Trends Amplif.* 2001; 5: 1-34.
10. Moore BCJ. Dead regions in the cochlea: Conceptual foundations, diagnosis, and clinical applications. *Ear Hear.* 2004; 25: 98-116.
11. Aazh H, Moore BCJ. Dead regions in the cochlea at 4 kHz in elderly adults: relation to absolute threshold, steepness of audiogram, and pure tone average. *J. Am. Acad. Audiol.* 2007; 18: 96-107.
12. Vinay, Moore BCJ. Prevalence of dead regions in subjects with sensorineural hearing loss. *Ear and Hearing* 2007; 28: 231-241.
13. Moore BCJ, Glasberg BR, Stone MA. New version of the TEN test with calibrations in dB HL. *Ear Hear.* 2004; 25: 478-487.
14. Pumpilin J. Low-noise noise. *J. Acoust. Soc. Am.* 1985; 78: 100-104.
15. Cairns S, Frith R, Munro KJ, Moore BCJ. Repeatability of the TEN(HL) test for detecting cochlear dead regions. *Int. J. Audiol.* 2007; 46: 575-584.
16. Vickers DA, Moore BCJ, Baer T. Effects of lowpass filtering on the intelligibility of speech in quiet for people with and without dead regions at high frequencies. *J. Acoust. Soc. Am.* 2001; 110: 1164-1175.
17. Baer T, Moore BCJ, Kluk K. Effects of lowpass filtering on the intelligibility of speech in noise for people with and without dead regions at high frequencies. *J. Acoust. Soc. Am.* 2002; 112: 1133-1144.
18. Simpson A, Hersbach AA, McDermott HJ. Improvements in speech perception with an experimental nonlinear frequency compression hearing device. *Int. J. Audiol.* 2005; 44: 281-292.
19. Glista D, Scollie S, Bagatto M, Seewald R, Parsa V, Johnson A. Evaluation of nonlinear frequency compression: Clinical outcomes. *Int. J. Audiol.* 2009; 48: 632-644.
20. Vinay, Moore BCJ. Speech recognition as a function of highpass filter cutoff frequency for subjects with and without low-frequency cochlear dead regions. *Journal of the Acoustical Society of America* 2007; 122: 542-553.
21. Vinay, Moore BCJ, Baer T. Speech recognition in noise as a function of highpass-filter cutoff frequency for people with and without low-frequency cochlear dead regions. *J. Acoust. Soc. Am.* 2008; 123: 606-609.
22. Moore BCJ, Alcántara JI. The use of psychophysical tuning curves to explore dead regions in the cochlear. *Ear Hear.* 2001; 22: 268-278.
23. Halpin C. The tuning curve in clinical audiology. *Am. J. Audiol.* 2002; 11: 56-64.
24. Vinay, Moore BCJ. Psychophysical tuning curves and recognition of highpass and lowpass filtered speech for a person with an inverted V-shaped audiogram. *J. Acoust. Soc. Am.* 2010; (submitted).
25. Moore BCJ, Glasberg BR, Schlueter A. Detection of dead regions in the cochlea: Relevance for combined electric and acoustic stimulation. In: van de Heyning P, Kleine Punte A, eds. *Cochlear Implants and Hearing Preservation. Advances in ORL*, 67. Basel: Karger; 2009.
26. Vinay, Moore BCJ. TEN(HL)-test results and psychophysical tuning curves for subjects with auditory neuropathy. *Int. J. Audiol.* 2007; 46: 39-46.
27. Rance G. Auditory neuropathy/dys-synchrony and its perceptual consequences. *Trends Amplif.* 2005; 9: 1-43.
28. Langenbeck B, *Textbook of Practical Audiometry*, London: Edward Arnold; 1965.



Correspondence can be addressed to Brian Moore, Department of Experimental Psychology, University of Cambridge, England, e-mail: bcjm@cam.ac.uk

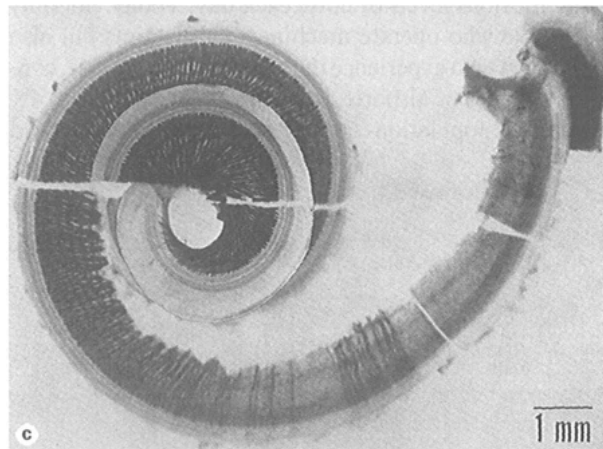

Figure 1: Cochlea from a 25-year-old man who had been exposed to gunshots. The dark lines show auditory neurons. There are no neurons coming from the basal part of the cochlea, indicating a dead region.

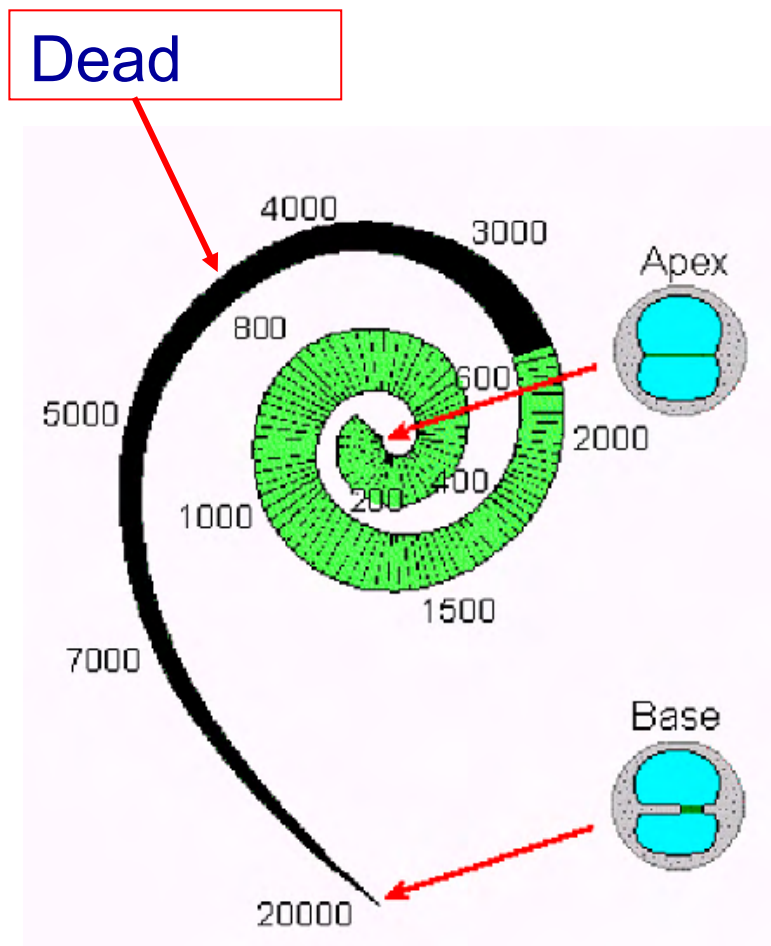

Figure 2: Illustration of how the edge of a dead region can be related to frequency in Hz, using a frequency-to-place map of the cochlea. In this example, the dead region starts at an edge frequency of about 2500 Hz and extends upwards towards higher frequencies.

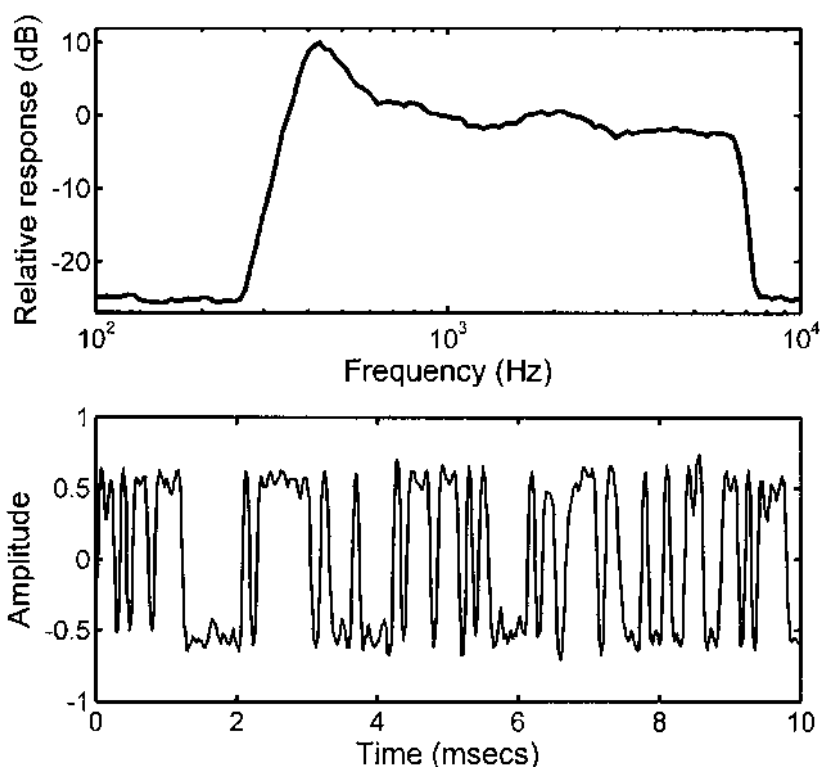

Figure 3: Spectrum (top) and a segment of the waveform (bottom) of the noise used for the TEN(HL) test.



Figure 4. Screen shot from the Callisto™ system. The open circles show the audiometric (absolute) thresholds. The “TEN” symbols show masked thresholds measured for TEN with a level of 80 dB HL. The TEN(HL)-test criteria for a dead region are met at 1.5, 3, and 4 kHz. The result at 2 kHz is inconclusive, as the masked threshold is not 10 dB or more above the audiometric threshold. In such a case, the result at 2 kHz could be checked using a TEN level of 90 dB HL. Overall, the results suggest that this patient has a dead region extending from 1.5 kHz upwards.



1.17 Appendix 2

1.17.1 Masking help/automasking quick guide

Masking help

Interacoustics masking help is available to make it easier to decide on a safe and correct masking intensity. When masking help is activated, a status light on channel 2 indicates if masking is applied correctly.



Masking help is activated by selecting the icon with the mask.



Gray indicates that the masking help is not active.



Green indicates that masking is correctly applied. Optionally, the masking help can give a suggested masking level. The example here shows that 85 dB, but also 75dB is in within the safe masking range.

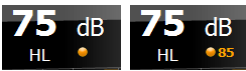

Amber indicates that masking is recommended differently. There is either too much or too little masking.

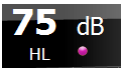

Purple indicates that masking would be recommended but is practically impossible.

Recommendations

- Because several masking intensities will usually be correct, experienced audiologists are recommended to use the masking help without displaying the recommended masking level.
- When measuring the second ear, more information becomes available, and it is not guaranteed that the earlier measurements are still correct. By measuring the best ear first and completing air conduction on both ears before measuring bone conduction, most errors can be avoided.
- Clinicians do often not apply masking for bone conduction in the instance where the air-bone gap is less than 10 dB in the better ear. Against general practice, masking help will always recommend that masking is needed in these cases.

Automasking

Interacoustics auto masking is available to ease the effort required to mask with correct masking levels. When auto masking is enabled, channel 2 is controlled by the system and is set to the appropriate intensity level.



Auto masking is activated by selecting the icon that shows the mask with letter A.



Green indicates that masking is correctly applied.

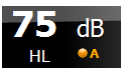

Amber indicates that masking is recommended louder, and that extended range needs to be activated to allow setting channel 2 to the correct level.

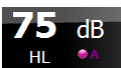

Purple indicates that masking would be needed but is practically impossible.



Recommendations

- Be aware that patients require proper instructions before audiometry with masking is undertaken. The switching on and off the masking noise may be uncomfortable to some patients and cause them to become more fatigued. In some cases (when testing young children, some elderly patients or difficult to test patients), it is recommended not to use masking because confusion about the application of masking noise may lead to false responses.
- When measuring the second test ear, more information becomes available, and it is not guaranteed that the earlier measurements are still correct. By measuring the best ear first and completing air conduction on both ears before measuring bone conduction, most errors can be avoided.
- Be careful when storing thresholds where masking was not possible. Masking not possible means that the risk for crossover hearing is high. In these cases, it is recommended to store a no-response at the loudest intensity where masking was still possible (by pressing the N key).

Additional information

The masking help calculates answers to the following questions.

- Is masking required?
- Is the masking level too low?
- Is the masking level too high?
- Is masking impossible?

Terminology

AC	AC test ear
AC _c	AC contra
BC	BC test ear
BC _c	BC contra
IaA	Minimum interaural attenuation
IaA _c	Minimum interaural attenuation contra transducer
Dial	Dial setting test ear
Dial _c	Dial setting contra (masking level)

Is masking required?

Masking is recommended when the presentation at the test ear leads to a response due to detection by the contralateral ear, or in a formula:

$$\text{Dial} - \text{IaA} \geq \text{lowest of AC}_c \text{ and BC}_c$$

Is the masking level too low?

The applied masking level is too low when the applied masking level does not match the intensity at which the test signal is heard in the contralateral ear, or in a formula:

$$\text{Dial}_c - (\text{AC}_c - \text{BC}_c) < \text{Dial} - \text{IaA}$$

Is the masking level too high?

The applied masking level is too high when the masking level is so loud that it potentially is heard by the test ear, or in a formula:

$$\text{Dial}_c - \text{IaA}_c \geq \text{Dial} - (\text{AC} - \text{BC})$$

Is masking impossible?

Masking is not possible when the needed masking level results in overmasking at the same time:

$$\text{Dial} + (\text{AC}_c - \text{BC}_c) - \text{IaA} \geq \text{Dial} - (\text{AC} - \text{BC}) + \text{IaA}_c$$

or when the needed masking level is higher than the maximum level of the masking transducer:

$$\text{Dial} + (\text{AC}_c - \text{BC}_c) - \text{IaA} > \text{maximum available Dial}_c$$



Recommended masking intensity

The masking help can indicate a recommended masking intensity. If masking is indeed required and possible, the recommended masking intensity is given by the minimum required masking level plus a fixed preferred amount:

$$\text{Recommended Dial}_c = \text{Dial} - \text{IaA} + (\text{AC}_c - \text{BC}_c) + \text{preferred additional amount}$$

The recommended masking level is adjusted for values that cannot be reached by the masking transducer due to maximum values.

When the auto masking feature is used, masking intensities are set to the recommended intensity. Of course, if “extended range” is not switched on, the masking intensities are thereby limited accordingly.

Frequency specific inter-aural attenuation

The default inter-aural attenuations used by the masking help are frequency specific and can be customized in the setup. The following table shows the default inter-aural attenuation values (IaA). These are partly based on recommendations from the Handbook of Clinical Audiology²⁶ and are otherwise slightly more conservative than recent publications and will therefore allow for appropriate decision making.’

Frequency (Hz)	125	250	500	750	1000	1500	2000	3000	4000	6000	8000
IaA Headphones (dB)	35	40	40	40	40	40	40	45	50	50	50
IaA Inserts (dB)	50	50	50	50	50	50	50	50	50	50	50
IaA Bone (dB)	0	0	0	0	0	0	0	0	0	0	0
IaA Free field (dB)	0	0	0	0	0	0	0	0	0	0	0

Recommendations

- Experienced audiologists are recommended not to use the option of viewing a suggested masking level.
- The masking help indicates if masking is performed correctly with the information given at the time of the measurement. When measuring the second ear, more information becomes available, and it is not guaranteed that the earlier measurements are still correct. By measuring the best ear first and completing air conduction on both ears before measuring bone conduction, most errors can be avoided.
- Although clinicians do often not apply masking for bone conduction in the instance where the air-bone gap is less than 15 dB in the better ear, it can be recommended to apply masking to make the measure ear specific. Despite that experienced clinician would disagree, the masking help will in these cases recommend that masking is needed. (This figure illustrates such situation.)

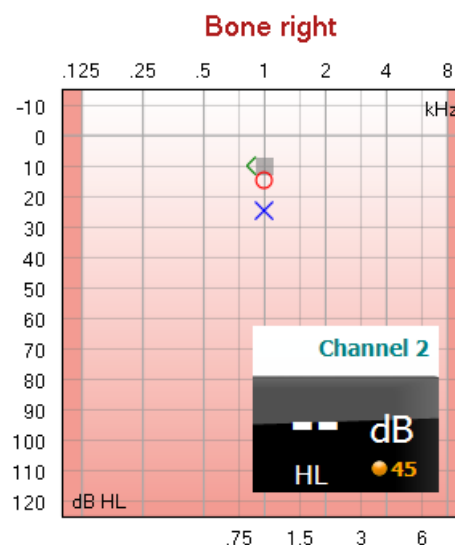

²⁶ Jack Katz et al. (2002), *Handbook of Clinical Audiology fourth edition*, Williams & Wilkins



1.18 Technical specifications of the AC440 software

1.18.1 Technical specifications of the AC440 software

Medical CE-mark:	The CE-mark indicates that Interacoustics A/S meets the requirements of Annex II of the Medical Device Directive 93/42/EEC. Approval of the quality system is made by TÜV – identification no. 0123.	
Audiometer Standards:	Tone: IEC60645-1/ANSI S3.6 Type 1 Speech: IEC60645-2/ANSI S3.6 Type A or A-E	
Transducers & Calibration	Calibration information and instructions are in the Service manual. Check the accompanying Appendix for RETSPL levels for transducers	
Air Conduction		
DD45	ISO 389-1 2017, ANSI S3.6-2018	Headband Static Force 4.5N ±0.5N
TDH39	ISO 389-1 2017, ANSI S3.6-2018	Headband Static Force 4.5N ±0.5N
DD65 v2	PTB 1.61-4091606/18, AAU 2018	Headband Static Force 11.5N±0.5N
HDA300	PTB report 1.61.4066893/13	Headband Static Force 8,8N ±0.5N
DD450	ISO 389-8 2004, ANSI S3.6-2018	Headband Static Force 10N ±0.5N
E.A.R Tone 3A/5A	ISO 389-2 1998, ANSI S3.6-2018	
IP30	ISO 389-2 1998, ANSI S3.6-2018	
CIR 33	ISO 389-2	
Bone Conduction	Placement: Mastoid	
B71	ISO 389-3 2016, ANSI S3.6-2018	Headband Static Force 5.4N ±0.5N
B81	ISO 389-3 2016, ANSI S3.6-2018	Headband Static Force 5.4N ±0.5N
Free Field	ISO 389-7 2005, ANSI S3.6-2018	
High Frequency	ISO 389-5 2004, ANSI S3.6-2018	
Effective masking	ISO 389-4 1994, ANSI S3.6-2018	
Patient response switch	Handheld push button.	
Patient communication	Talk Forward and Talk Back.	
Monitor	Output through external earphone or speaker.	
Stimuli	Pure tone, Warble tone, NB, SN, WN, TEN noise, Wave files.	
Tone	125-16000Hz separated in two ranges 125-8000Hz and 8000-16000Hz. Resolution 1/2-1/24 octave.	
Warble Tone	1-10 Hz sine +/- 5% modulation	
Wave file	44100Hz sampling, 16 bits, 2 channels	
Masking	Automatic selection of narrow band noise (or white noise) for tone presentation and speech noise for speech presentation.	
Narrow band noise:	IEC 60645-1:2001, 5/12 Octave filter with the same centre frequency resolution as pure Tone.	
White noise:	80-16000Hz measured with constant bandwidth	
Speech Noise.	IEC 60645-2 1993 & ANSI S3.6 2010: 125-6000Hz falling 12dB/octave above 1KHz +/-5dB	
Presentation	Manual or Reverse. Single or multiple pulses. pulse time adjustable from 200ms-5000ms in 50mS steps. Simultaneous or alternating.	
Intensity	Check the accompanying Appendix for maximum output levels	
Steps	Available Intensity Steps is 1, 2 and 5dB	
Accuracy	Sound pressure levels: ± 2 dB Vibration force levels: ± 5 dB	
Extended range function	If not activated, the Air Conduction output will be limited to 20 dB below maximum output.	
Frequency	Range: 125Hz to 8kHz (Optional High Frequency: 8 kHz to 16 kHz) Accuracy: Better than ± 1 %	



Distortion (THD)	Sound pressure levels: below 1.5 % Vibration force levels: below 3 %.
Signal Indicator (VU)	Time weighting: 350mS Dynamic range: -20dB to +3dB Rectifier characteristics: RMS Selectable inputs are provided with an attenuator by which the level can be adjusted to the indicator reference position(0dB)
Storing capability	Tone audiogram: dB HL, MCL, UCL, Tinnitus, R+L Speech Audiogram: WR1, WR2, WR3, MCL, UCL, Aided, Unaided, Binaural.
Compatible software	Noah 4, OtoAccess® and XML compatible



2 REM440

2.1 Quick guide

- 1) Open **Noah** and double click on any client:

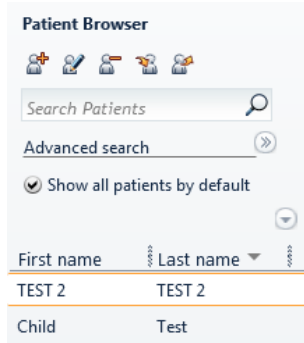

- 2) Select the **Callisto™** icon from the menu bar

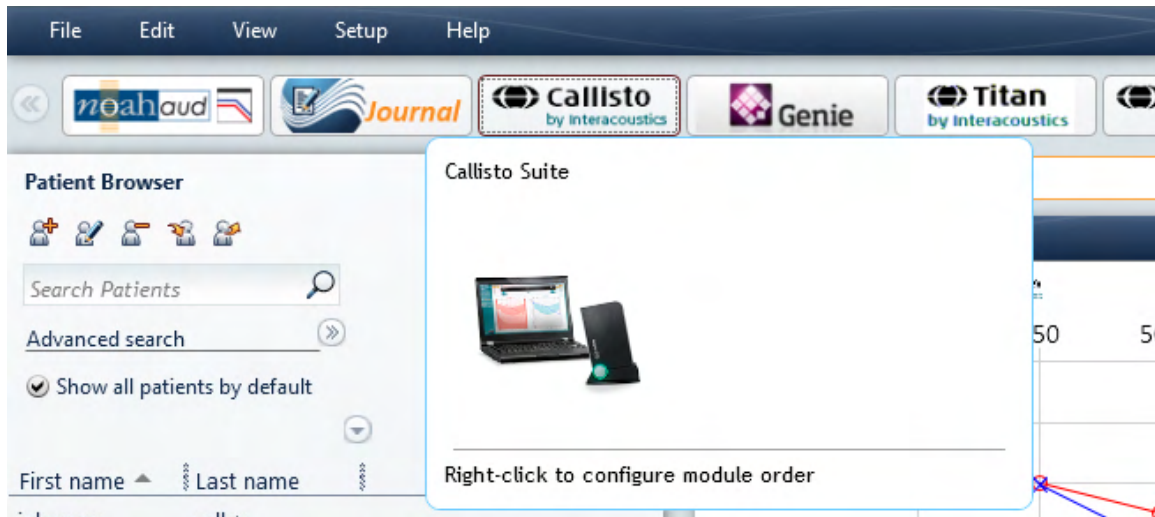



- 3) To view an audiogram, you can select an older audiogram from a previous session, or you can manually enter an audiogram. You can configure your REM module to automatically use the most recent Audiogram if desired.

NOTE: to have targets displayed, there needs to be an audiogram selected.

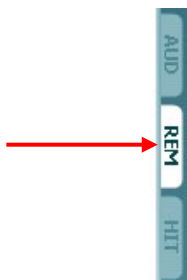
- 4) Enter the REM module using the **REM tab** in the upper right corner of the screen:





- 5) Select the desired test protocol in the **protocol list**.  Both user-defined and standard test protocols can be found in this dropdown list
- 6) Perform **Tube Calibration**  if this is not already done. It is recommended to perform the tube calibration at least once a day. **If using a regular probe tube, click “NO” when asked whether the calibration should be performed with the SPL probe.**
- 7) Perform otoscopy and insert the probe tube into the ear.

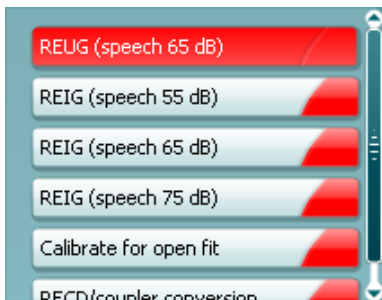

Choose the **Test Ear** in the upper left corner. Choose the test you wish to perform by clicking on it in the protocol list:

- 8) Select **Stimulus** in the stimulus dropdown list 
- 9) If needed adjust the **Input Level** using the slider to the right:

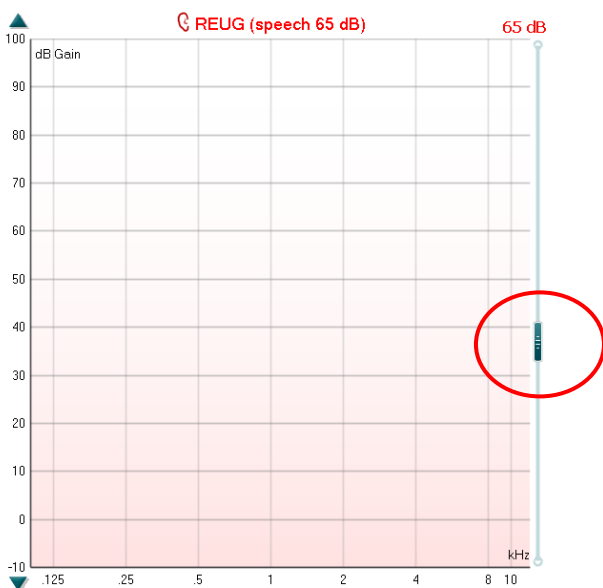

Click **START**  to perform real-ear measures.

Save the measurements of your session by clicking the **Save** icon 



2.2 About REM440

The REM440 is a user-friendly and **intuitive** Real-Ear Measurement software which enables you to satisfy your Hearing Aid verification requirements.

A great advantage is the flexibility which permits the creation of an unlimited number of personalized test flows or “test protocols” for different purposes and/or for different audiologists working in the same clinic. This enables each individual clinician to setup the module exactly the way they wish including the specific tests, stimuli, and settings they prefer. These personal test protocols can swiftly and easily be chosen at any time accommodating the need for speed in a busy clinic.

The REM440 also allows you to make individual print layouts, keep reports electronically and compare actual curves to previous sessions. These numerous setup options can be very helpful and time saving in the clinic. In addition to the setup functions, the counselling tool Visible Speech Mapping (VSPM440)²⁷ can also be added to the REM440. This helps both client and relatives to get a better understanding of the benefits of the hearing aids, the effects of their hearing impairment and how the hearing aids can improve their quality of life.

2.3 REM440 tests

The REM440 contains the following tests:

- REUR (Real-ear Unaided Response)/REUG (Real-ear Unaided Gain)
- REAR (Real-ear Aided Response)/REAG (Real-ear Aided Gain)
- REIG (Real-ear Insertion Gain)
- RECD (Real-ear to Coupler Difference)
- REOR (Real-ear Occluded Response)/REOG (Real-ear Occluded Gain)
- Input /Output
- Directionality
- Visible Speech Mapping
- FM Transparency Verification²⁸
- Ear Level FM-only REM test²⁹

²⁷ Visible Speech Mapping (VSPM440) requires an additional software license.

²⁸ Based on the American Academy of Audiology Clinical Practice Guidelines for Remote Hearing Assistance Technologies for Children and Youth from Birth to 21 Years

²⁹ Based on the American Academy of Audiology Clinical Practice Guidelines for Remote Hearing Assistance Technologies for Children and Youth from Birth to 21 Years



2.4 Launching REM440

Ensure that the Callisto™ is connected before opening the software suite. If the hardware is not detected the Callisto™ Suite will run in Simulation mode. When this happens, you will see this indicator in the bottom left of the software:

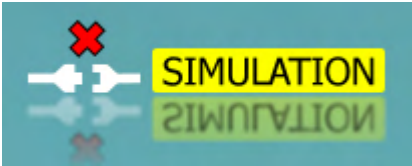

2.4.1 Launching REM440 from Noah:

If you are using HIMSA's Noah 4, the Callisto™ Suite software will install itself automatically in the menu bar on the start page, along with all the other software modules.

For further instructions about working with Noah please see the Noah operation manual.

2.4.2 Launching REM440 from OtoAccess®:

For further instructions about working with OtoAccess®, please see the OtoAccess® operation manual.



2.5 The REM screen elements

The following section describes the elements of the REM screen:



Menu



Menu provides access to File, Edit, View, Mode, Setup, and Help.



Print button will print the test results using the selected print template. If no print template is selected the results currently displayed on the screen will be printed.



Save & New session button saves the current session in Noah or OtoAccess® and opens a new one.



Save & Exit button saves the current session in Noah or OtoAccess® and exits the Suite.

Right Click



Change Ear button allows you to toggle between right and left ear. Right click on the ear icon to view *both ears*.



NOTE: Binaural REM measurements can be performed when both ears are viewed (in both REIG measures and REAR). The binaural feature enables the fitter to view the binaural right and left measurements simultaneously



Toggle between Single and Combined Screen button toggles between viewing one or multiple measurements in the same REM graph.

Toggle between Single and Continuous Measurement button toggles between running a single sweep or having a test signal running continuously until pressing STOP.



Freeze Curve allows for taking a snapshot of a REM curve when testing with broadband signals. In other words, the curve freezes at a particular moment while the test continues. Note that if too many curves are frozen on the screen not all will be saved in Noah due to imposed limitations.

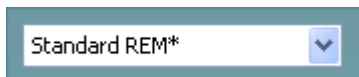

List of Protocols allows you to select a test protocol (default or user defined) to use in the current test session.



Temporary Setup button allows for making temporary changes to the selected test protocol. The changes will be valid for the current session only. After making the changes and returning to the main screen, the name of the test protocol will be followed by an asterisk (*).

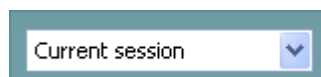

List of Historical Sessions accesses previous real-ear measurements obtained for the selected patient, for comparison or printing purposes.



Toggle between Lock and Unlock the Selected Session freezes the current or historical session on the screen for comparison to other sessions.



Go to Current Session button brings you back to current session.



Toggle between Coupler and Ear button allows you to toggle between real-ear and coupler mode.

Note: This icon only becomes active if a predicted or measured RECD is available.



Report Editor button opens a separate window for adding notes to the current session. Note that after saving the session, no changes can be made to the report outside of the save date.



Single Frequency button is a test that lets the fitter play a single frequency warble tone. Once clicked, the exact frequency, input and output can be seen on the graph. The frequency can be adjusted up and down by using the Right and Left arrows on the keyboard. Click on the button to turn it on and click on it again to turn it off.

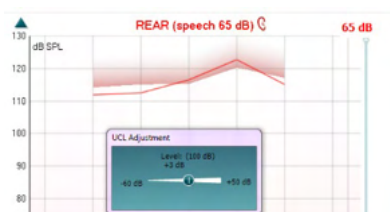
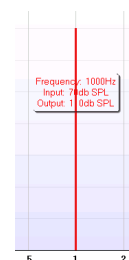

UCL (Uncomfortable Levels) Adjustment To limit the system's signal intensity while measuring the MPO during a Real-Ear situation, the UCL button can be activated. Once activated, a red line will appear on the graph and the system will stop measuring if this UCL level is reached. This red line can be adjusted with the slider.

NOTE: UCL thresholds must be entered on the audiogram for the patient specific UCL red line to appear when the UCL button is active. If no ULL's exist a flat line will be available to the user. To deactivate this feature, press on the UCL button again.



On Top Mode button converts the REM440 into an on top window that includes only the most essential REM features. The window is automatically placed on top of other active software programs such as the relevant hearing aid fitting software.

Whilst adjusting the gain handles in the fitting software, the REM440 screen will always stay on top of the fitting screen allowing for easy curve comparison.

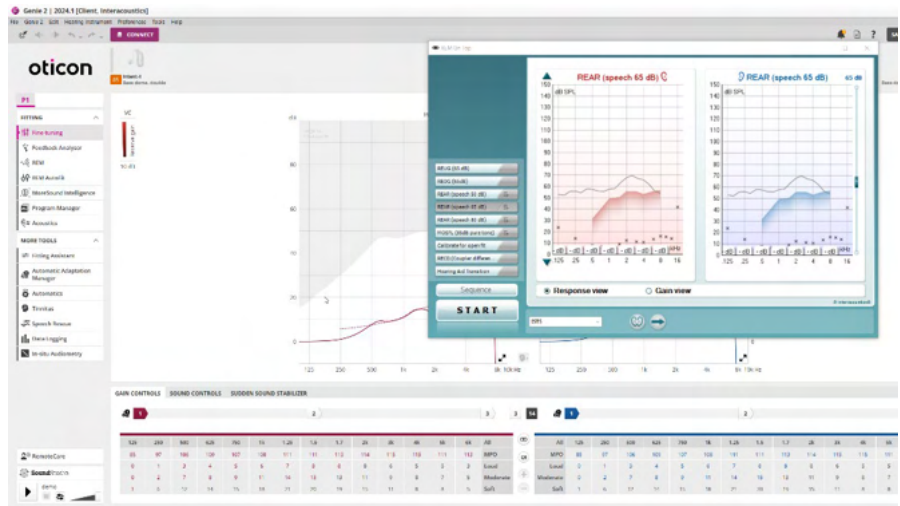

To return to the original REM440 press the red cross in the upper right-hand corner. 



Tube calibration button activates the tube calibration. Before measuring it is recommended to calibrate the probe tube. This is done by pressing the calibration button. Follow the instructions appearing on the screen (see screen below) and press OK. The calibration will then automatically be performed resulting in the curve below. Note that the calibration is sensitive to noise and the clinician should therefore ensure that the room is quiet whilst calibrating.

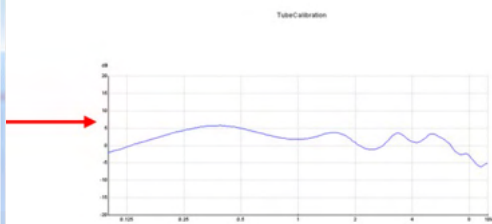
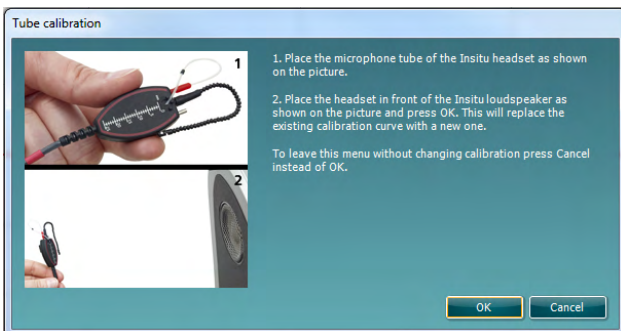

Simple View/Advanced View buttons toggle between an advanced screen view (including the test and fitting prescription information on the right-hand side) and a simpler view with a larger graph only.

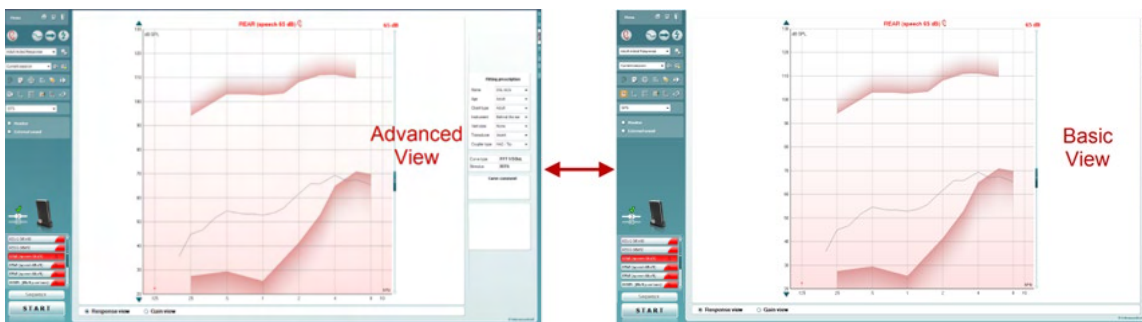

Normal and Reversed Coordinate System buttons enable you to toggle between reversed and normal graph displays. This may be helpful for counselling purposes since the reversed view look more like the audiogram and may therefore be easier for the client to comprehend when explaining his/her results.



Insert/Edit Target button allows you to type in an individual target or edit an existing one. Press the button and insert the preferred target values in the table as illustrated below. When satisfied click **OK**.

Edit target

Frequency (Hz)	125	250	500	750	1000	1500	2000	3000	4000	6000	8000	10000
Intensity (dB)		53	62	60	61	63	67	69	65	61	57	

OK Cancel



Table View button provides a chart view of the measured and target values.

Table view

	125	250	500	750	1000	1500	2000	3000	4000	6000	8000	10000
REUG (65 dB)												
REAR (speech 55 dB)												
55 dB	66	63	65	67	67	60	61	67	70	74		
55 dB-T	54	57	54	53	56	60	60	58	53	49		
REAR (speech 65 dB)												
65 dB	73	70	73	70	80	83	83	86	89	83		
65 dB-T	64	67	64	63	66	70	70	68	63	59		
REAR (speech 75 dB)												
75 dB	86	86	84	82	80	85	79	78	76	75		
75 dB-T	65	73	77	76	83	86	85	82	72	66		
REAR (pure tone 80 dB)												
80 dB	119	119		121		119		119		120		
80 dB	120	120		121		119		119		118		



Show Cursor on Graph locks the cursor to the curve, displaying the frequency and intensity at any given point along the measure curve.

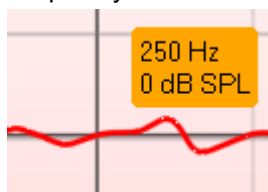

Use Opposite Reference Microphone lets the fitter use a reference microphone is on the opposite to the one in which the probe



measurement microphone is in. To use this feature, position the probe tube in the patient's ear, with the hearing aid in. Position the other reference microphone on the other patient's ear. By pressing on this button, the reference mic on the opposite side is the one be used during the measurement. This type of scenario is often used in CROS and BiCROS fittings.



Single Graph lets the fitter view the binaural measurement in one graph, overlaying the curves from the left and the right ear on top of one another.



Delta values display values at the bottom of the graph informing about the difference between measurement curve and target.

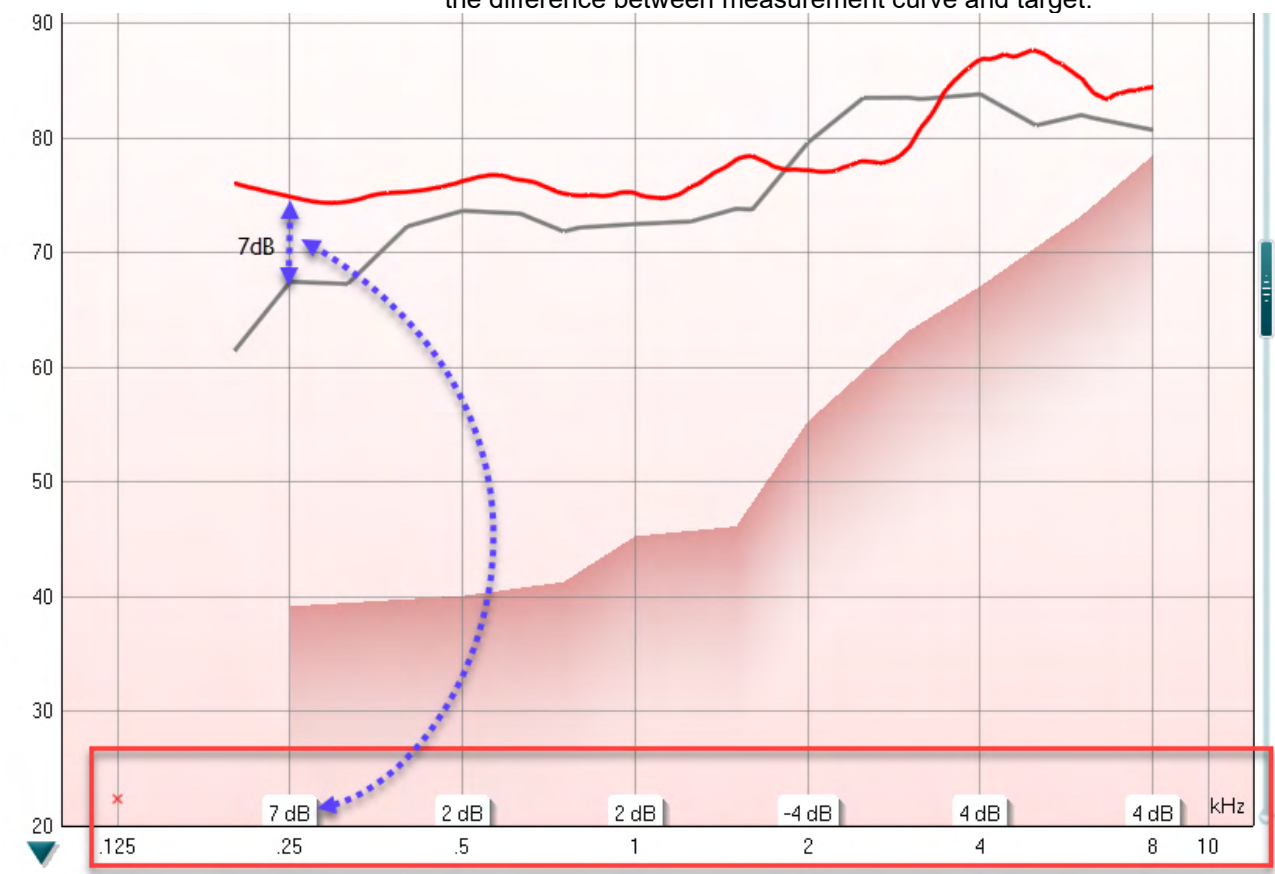

ISTS

Stimulus Selection allows for selecting a test stimulus.

Monitor

Monitor: If you wish to listen to the amplified stimulus through a monitor.

1. Connect a monitor headset to the monitor output on the hardware. It is recommended to use only a monitor headset which is approved by Interacoustics.
2. Tick the Monitor check box.
3. Use the slider to turn the sound level up and down.

Note that the sound from the monitor may be very soft (compared to the audiometry monitoring). It is louder for audiometry because the audiometric equipment is producing the signal that is monitored. In



REM440 the hearing instrument produces the monitored signal meaning that it cannot be controlled by the equipment.

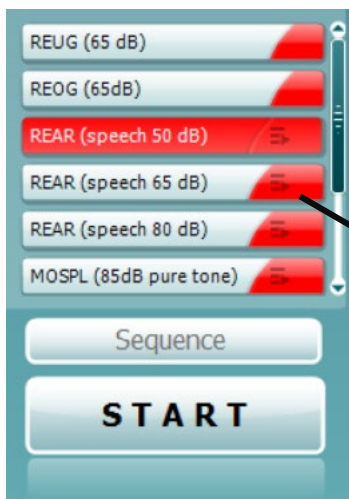

Current Protocol is listed in the lower left-hand corner. This highlights the test which you are currently performing and the other tests in the battery. The checkmarks indicate that a curve has been measured. Test protocols can be created and adjusted in the REM440 setup. **Color** on each test button indicates the color selected for each curve.

This sequencing icon allows the user to perform aided measurements sequentially. The icon can be selected and this will, in turn, make the icon bold: **5**. The user selects which input levels are required in the sequence.

Pressing this button **Sequence** will then run the selected measurements in automated sequence from top to bottom

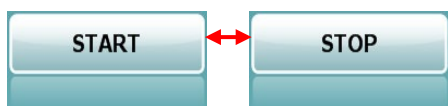

Start/Stop button initiates and ends the current test. Note that after pressing **START** the text on the button will change to **STOP**.



1. **The Graph** shows measured REM curves. The X-axis shows the frequency, and the Y-axis shows the intensity of the test signal.
2. **Gain/Response View** allows for toggling between viewing the curve as a gain or response curve. Note that this option is not available for REIG.
3. **Measurement Type** is indicated above the graph, with a right/left indication. In this example the REIG is displayed for the right ear.
4. **Change the Input Level** using the slider on the right-hand side.
5. **Scroll Graph Up/Down** on the left-hand side allows for scrolling the graph up or down ensuring that the curve is always visible in the middle of the screen.



Fitting prescription

Name: NAL-NL1

Age: Adult

Client type: Adult

Instrument: Behind the ear

Vent size: Open

Transducer: Head phone

Recorded method	FFT 1/3 Oct.
Input Level	65 dB SPL
Stimulus	ISTS
Measured in	Real Ear
Curve type	Measured
Smoothing index	5

Curve comment

Fitting Prescription and related details can be adjusted on the right-hand side of the screen. Select your preferred fitting prescription in the upper dropdown list. Choose between Berger, DSL $m[i/o]$, Half Gain, NAL-NL1, NAL-NL2, NAL-R, NAL-RP, POGO1, POGO2, Third Gain, or 'Custom' if you have edited your target with the Edit feature. Target shown will be calculated based on the selected fitting prescription and the audiogram and can be shown as REIG and/or REAR targets. **If no audiogram has been entered into the audiogram screen, no targets will be displayed.** Note that fitting prescription settings (such as *Age* and *Client type*) will differ depending on what fitting prescription is selected.

Measurement Details of the selected curve are displayed as a table on the right-hand side of the screen.

A Curve Comment for each curve can be typed into the comment section on the right-hand side. Select a curve using the curve tag boxes under Curve display options and write a comment in the comment section. The comment will then appear in the comment section whenever the curve is selected.

65 dB

65 dB

55 dB

55 dB

55 dB

55 dB

- Delete
- Delete all
- Change curve color

Curve Display Options are found in the lower right-hand corner. If you have measured more curves of the same type (e.g., REIG curves), they will be listed by their input level. Tick the ones that are to be displayed on the graph.

Right clicking on the input level in the curve display will give the fitter various options.

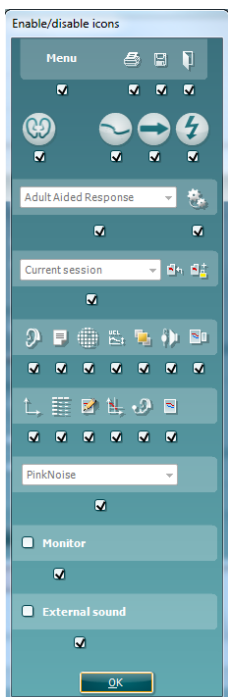

Enable/Disable Icons

This feature lets the fitter customize which buttons appear on the front of the main REM440 screen. When all the items are selected with the checkmark, all buttons will be displayed on the front screen. Removing the checkmark from the checkbox under the icons will remove those icons from the main REM440 screen.

To access this menu:

Go to **Menu** → **Setup** → **General Setup** and click on the Enable/disable icons button to customize

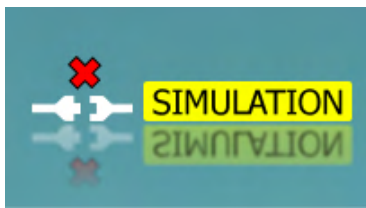

Hardware indication picture: The picture indicates whether the hardware is connected. When opening the Suite, the system will automatically search for the hardware. If it does not detect the hardware it will continue in simulation mode.



2.6 Background on real-ear measurements using REM440

When performing real-ear measurements there are certain things you should keep in mind to obtain the best possible result. Some of these will inevitably also influence the precision of the curve obtained.

This section will walk through some important tips and tricks to remember when doing real-ear measurements using the REM440.

2.6.1 Required items

- The Callisto™ hardware
- A REM Loudspeaker
- The REM440 software.
- An In-situ headset (including a reference microphone).
- A probe tube microphone.

Note: If performing the RECD a couple of further parts are needed (see section 2.7.4 for details).

- 1) The Callisto™ can be purchased with several external loudspeakers which can be plugged into the FF socket on the back of the Callisto™ hardware (see below). There are several different loudspeakers which are offered with purchase of the Callisto™ or as an accessory are compatible with the Callisto™ to perform REMs and these can be either active or passive but still connect in the same way.





The client should be seated in **½ - 1 meter's distance facing this loudspeaker** as illustrated above. This distance is a compromise between measurement precision and client comfort. The client shall be in this test position during all real-ear measurements.

- 2) Mount the probe tube on the small microphone on the in-situ headset and place it on the ear of the client using either the plastic headband or slide-on ear loop.

Plastic headband (click it on the plastic headband and hang it over the ears of the client).



Slide-on ear loop (slide on as shown below and hang it on the ear of the client).



The measurement tool on the headset allows for easy measurement of probe tube insertion depth and the probe tube stabilizer can be used to hold the probe in place.

Measurement tool

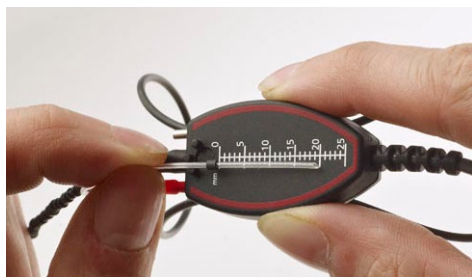

Probe tube stabilizer



Perform otoscopy and carefully insert the probe tube into the ear canal. Distance from ring to probe tube tip should be approximately 31mm for males, 28mm for females, and 20-25 for children.



- 3) The reference microphone on the headset monitors the amplitude of the signal reaching the hearing aid from the loudspeaker. If the input level is louder or softer than the desired level the reference microphone will turn the volume up or down accordingly.



2.6.2 Calibration

Sound is affected when passed through a small probe tube. This is considered by the probe tube calibration. The calibration process involves aligning the reference microphone and probe tube microphone to account for any differences. This ensures that once positioned the differences which are occurring are not caused by the hardware.

The calibration procedure should be performed at least once a day or per patient when changing the tube.

- Perform the tube calibration by clicking the calibration button in the front screen 
- A pop-up will then ask whether the calibration should be performed with the SPL probe used for RECD measure. **You should always choose “Regular Probe”, unless the SPL probe is being used for the RECD measurement (as per section 2.7.4.2)**

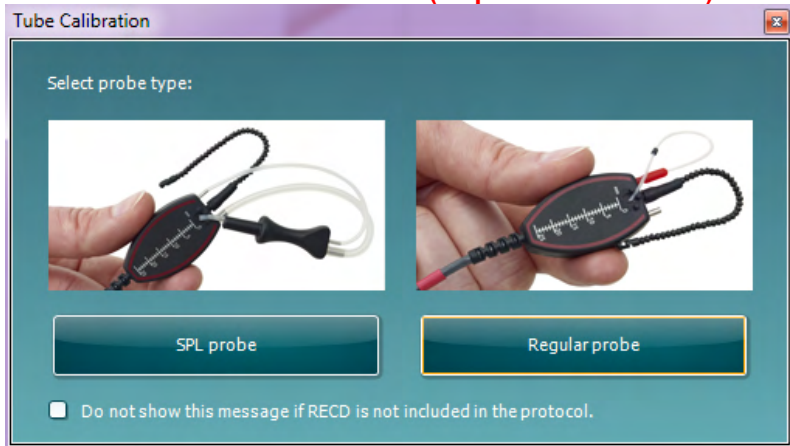



- Follow the instructions appearing on the screen:

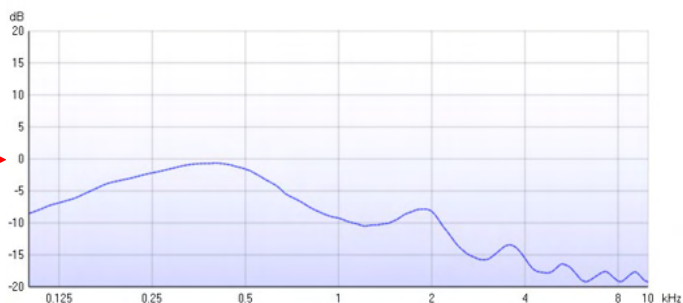
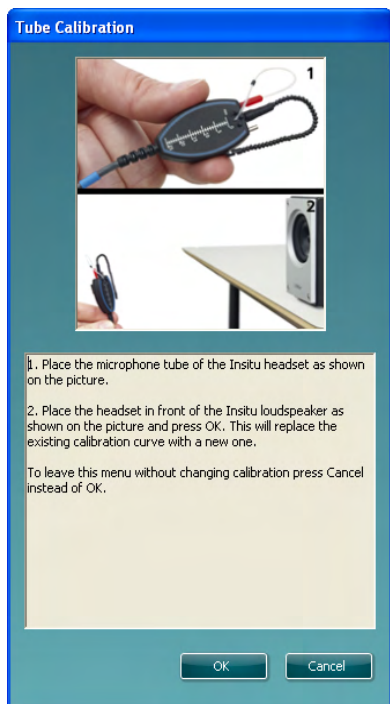

Note: If using an Callisto™ place the in-situ headset in front of the internal loudspeaker (as shown above for the Equinox² external loudspeaker) and press OK.

2.6.3 Gain versus response view

To understand the various real-ear measurement terms you should be aware of the way the real-ear acronyms are constructed.

Real-ear terms all end with either a “R” (e.g., REUR) or a “G” (e.g., REUG)

“R” refers to Response

Response measures consist of two things:

- What you measure in the ear
- The input you send into the ear (e.g., 50 dB SPL)

In other words, the response is the total measure of output in SPL at the eardrum (e.g., REUR)

“G” refers to Gain

Gain (e.g., REUG) is calculated by subtracting the input (in dB) you used for the response measure across frequency.

(Response – input = Gain)

This means that the input level used to generate the response is not included in the measurement result.

If you for example measure a value of 60 dB SPL in the ear canal at 2000 Hz when presenting a stimulus of 50 dB the gain is 10 dB.

	500	750	1000	1500	2000	3000	4000	6000	8000
R									
E									
U									
R									



The REM440 allows for showing real-ear measurements as both gain and response curves. The gain curve is automatically generated from the response curve which allows you to choose which view you prefer using the Gain and Response radio buttons below the graph:

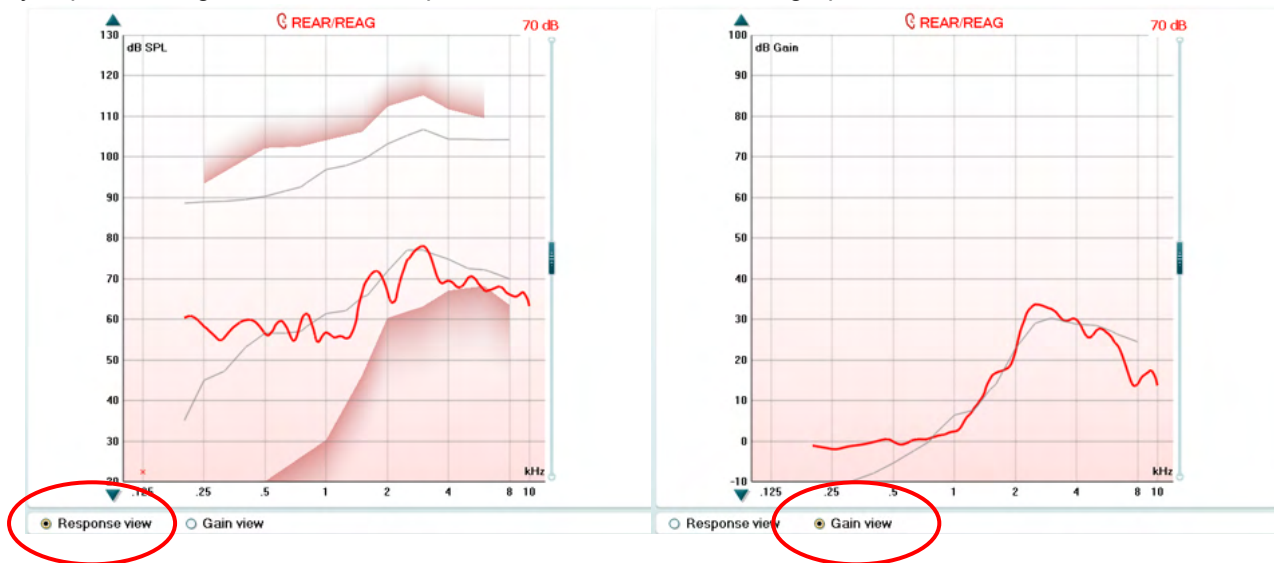

2.6.4 Real-ear measurements on open fittings

The increasingly popular open fit hearing instruments have many advantages relating to comfort, sound quality, and cosmetics; however, they introduce implications when it comes to Real-ear verification.

In traditional Real-Ear Measurements a reference microphone supervises the amplitude of the signal reaching the hearing instrument from the loudspeaker. If the input level is louder or softer than the selected level, the reference microphone will decrease or increase the volume of the stimulus accordingly. This ensures that the correct level enters the ear canal (Dillon 2001).

When performing Real-Ear Measurements on an open fitting, some frequencies may leak out of the ear canal and into the reference microphone causing the input level to be reduced to compensate. **This results in an erroneous curve below the target!**

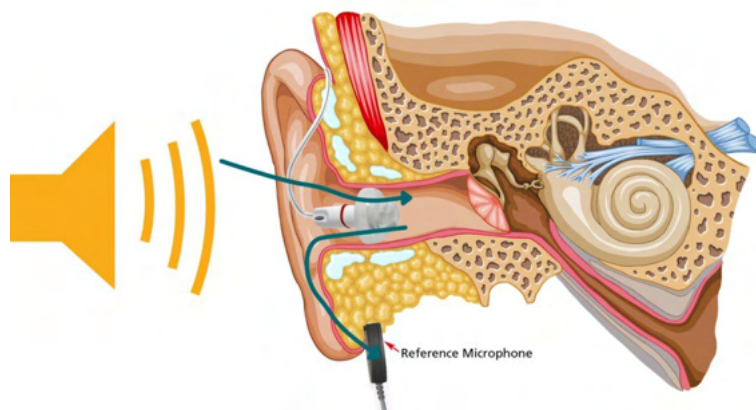

This issue is solved by using *Calibrate for open fit*.



2.6.4.1 Calibrate for open fit

Calibrate for open fit is the best way to cope with open fittings. Calibrate for open fit is done with the hearing aid in place muted or switched off.

During a stimulus presentation the reference microphone supervises the amplitude of the signal. It records how much of the signal leaks out of the ear canal at each frequency and adjusts the input level accordingly. This keeps the input at the correct level across the frequency range.

After the measurement is done the reference microphone switches off.

The adjustments across the frequency range will now be remembered and used as correction values for the following aided Real-Ear Measurements.

Since the reference microphone does not monitor the input level anymore the client **MUST avoid movements** during the aided Real-Ear Measures. If movements occur precision is compromised, and the measures will not be accurate.

Note: Calibrate for Open Fit can be added as a part of the individual test protocol in the REM440 setup the same way that other tests are added (see section **Error! Reference source not found.**).

Calibrate for open fit procedure:

1. Select *Calibrate for open fit* in the main screen.
2. Carefully insert the hearing aid without changing the position of the probe tube.
3. Press **START** and follow the instructions in the pop-up. Ensure that it is **MUTED/switched off!**
4. Press **OK** to continue with the measure.

The visual appearance of Calibrate for open fit will differ depending on the selected stimulus.

Measurements performed after Calibrate for open fit needs to be performed with the same stimulus as was used in Calibrate for open fit. However, you can now do multiple Calibrate for open fits. After performing these, only the stimuli that have been used for the Calibrate for open fits are selectable for the aided measures (E.g., REIG, REAR).

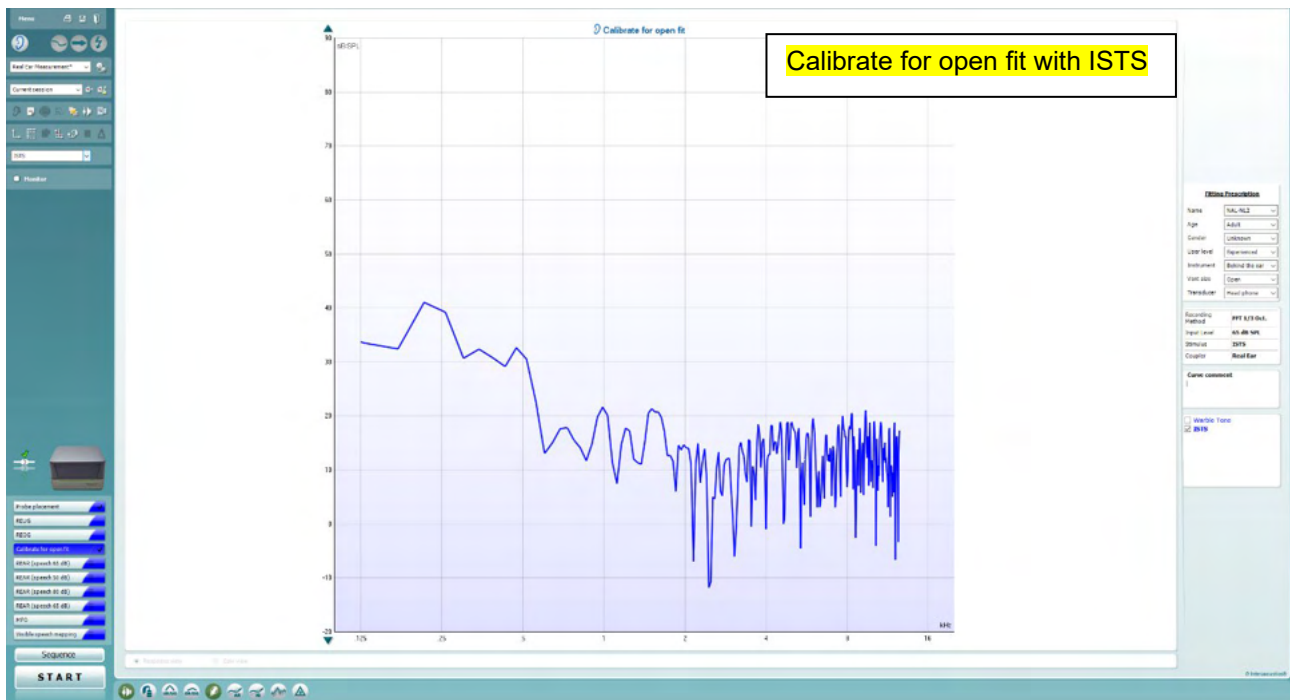

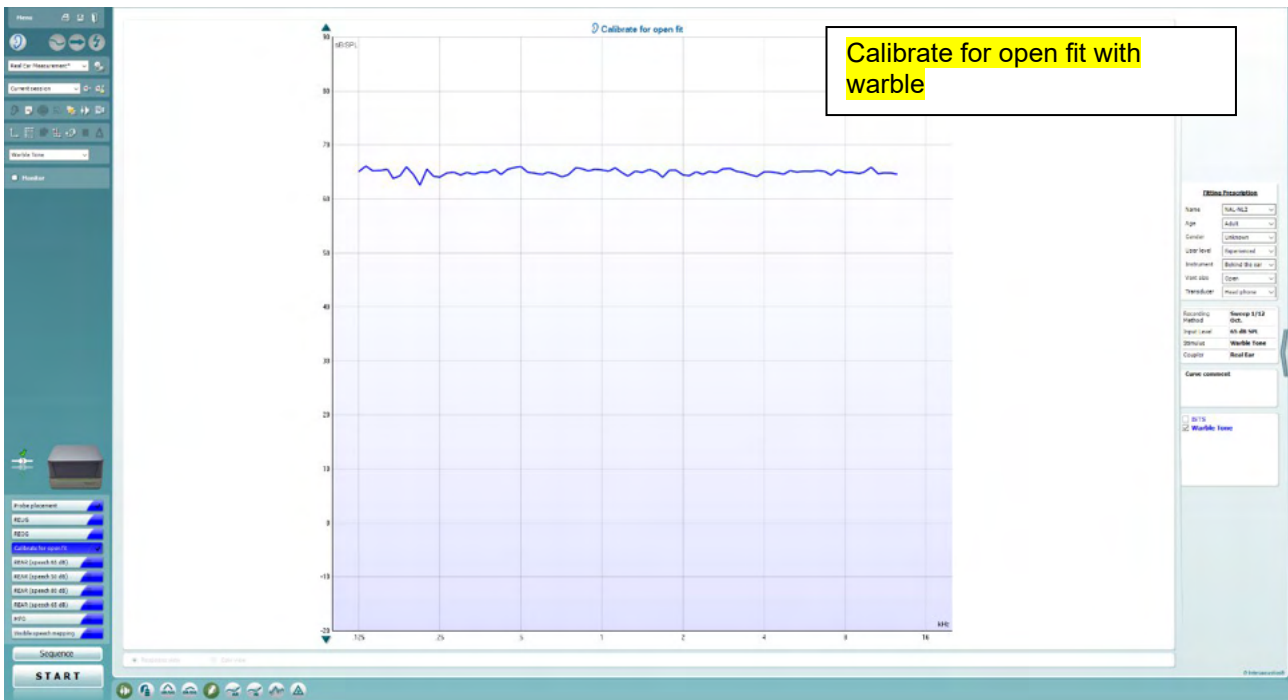

In this example when going to REIG/REAR the system will show Warble Tone and ISTS in the stimulus dropdown as both stimuli have been used to conduct a calibrate for open fit measurement.

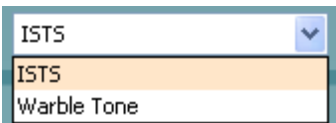

2.6.5 Probe placement

It is important that the probe is placed correctly in the ear of the client (e.g., within 5 mm of the eardrum).

Approximate insertion depths

- Females 27 mm past the inter-tragal notch
- Males 30-31 mm past the inter-tragal notch
- Children 20-25 mm past the inter-tragal notch

Use the black marking ring on the tube to help place the probe at the right depth in the ear canal. If uncertain the probe placement tool in the REM440 assist in inserting the probe correctly. This is accessed under **Menu/Mode/Probe Placement**.



When the red column appearing on the screen is as low as possible, mark this position on the probe and add 10 mm. Correct probe placement will then be obtained (Sullivan 1988). Click **STOP** to exit the probe placement tool.

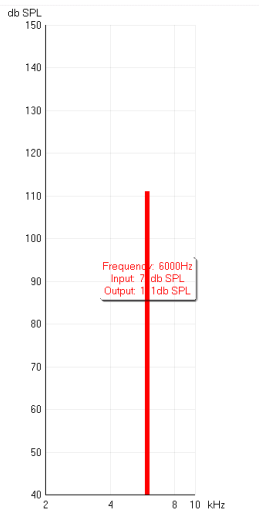

2.6.6 Stimuli for real-ear measures

Choosing the correct stimuli for the purpose is extremely important as it is the basis of a good measurement with a valid result. Digital hearing aids automatically adjust the amplification depending on the input. This feature, however, cannot be reflected in a real-ear measurement unless a realistic and dynamic test stimulus like speech for example is used (Fabry 2004).

2.6.6.1 Tone stimuli

For many years pure tones (sinusoids)/warble tones were the primary signals used for real-ear as well as coupler verification. Tone signals are “simple” signals and only one frequency is presented at a time. Therefore, real-ear measurements performed with tone signals do not reflect advanced signal processing (Kuk & Ludvigsen 2005).

2.6.6.2 Speech stimuli/ISTS

Speech is likely to be the most important signal to the hearing aid user in his or her daily life. Therefore, if you wish to verify if speech sounds are audible there is no better stimulus than speech. Furthermore, speech signals challenge the hearing aid since they have quick change in amplitude, frequency, and phase.

ISTS (International Speech Test Signal) is an internationally recognised test signal. It was created based on the need for a standard test stimulus that included all the relevant properties of speech and allowed for reproducible measurement conditions. It is created from natural recordings of speech which is non-intelligible due to remixing and segmentation. The signal reflects a female speaker for six different mother tongues (American English, Arabic, Chinese, French, German, and Spanish) reading “The north wind and the sun”. The ISTS is shaped according to the LTASS (Long Term Average Speech Spectrum) standards (Holube et al. 2007).

2.6.6.3 Composite signals/ICRA

Artificial signals without significant variation in intensity and frequency can also be used to test hearing aids in the frequencies of speech. These are called speech spectrum shaped composite signals and have the same long-term spectral characteristics as speech.



The advantages in such signals are that you can test many frequencies in a short time and that interactions among frequencies can be tested.

The ICRA signals (International Collegium of Rehabilitative Audiology) are examples of composite signals. They are a group of test signals developed by the HACTES group (Hearing Aid Clinical Test Environment Standardisation) to be able to do reliable measurements on non-linear digital hearing aids. They represent several speech weighted noise signals composed with spectral and temporal characteristics like those that are found in speech signals and babble noise. (www.icra.nu).

2.6.6.4 What stimulus to choose?

Which stimulus to select depends on your focus and the individual clients' complaints.

If, for example, you are seeing a client who complains about not being able to hear his wife, you may want to use the ISTS.

If the client is having trouble when more than one person is speaking, the ICRA 6pbl (or one of the other signals with multiple people speaking) may be selected.

If you wish to look at the effects of - noise reduction, a noise signal such Pink Noise may be the appropriate choice.



Note that your choice has an impact on your result as illustrated below:

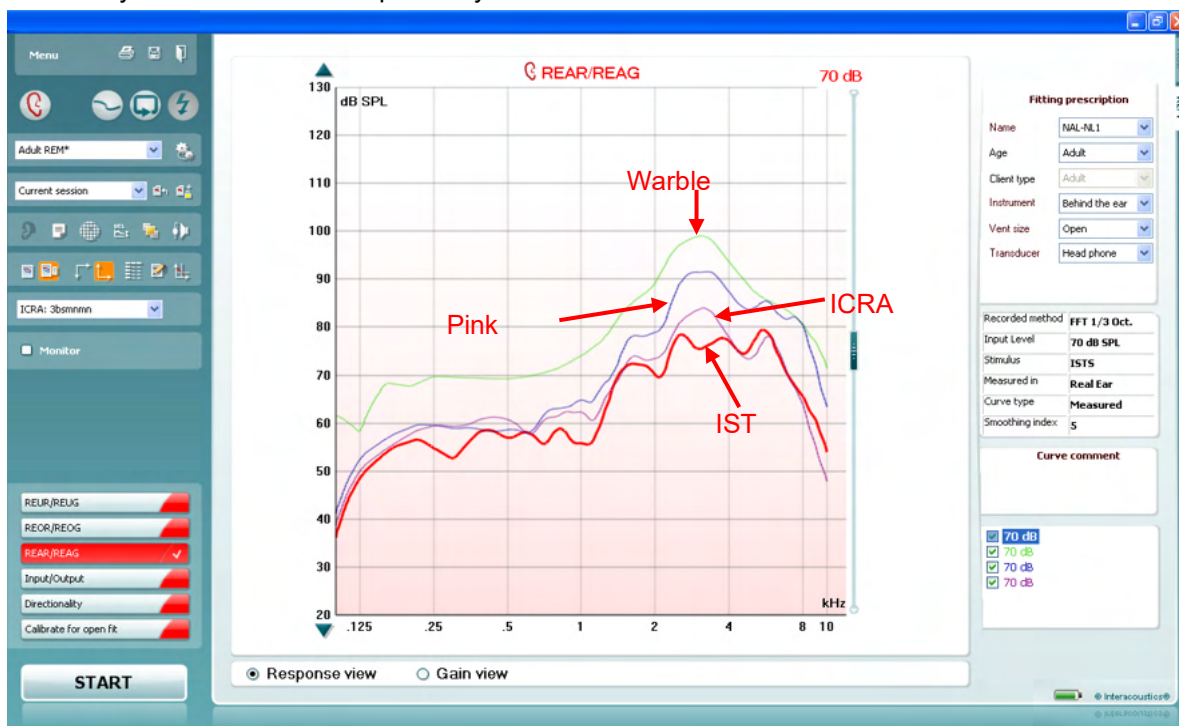

Note: The signals Male Speech, Female Speech, and ISTS are shaped according to LTASS standards.

2.6.7 Referencing

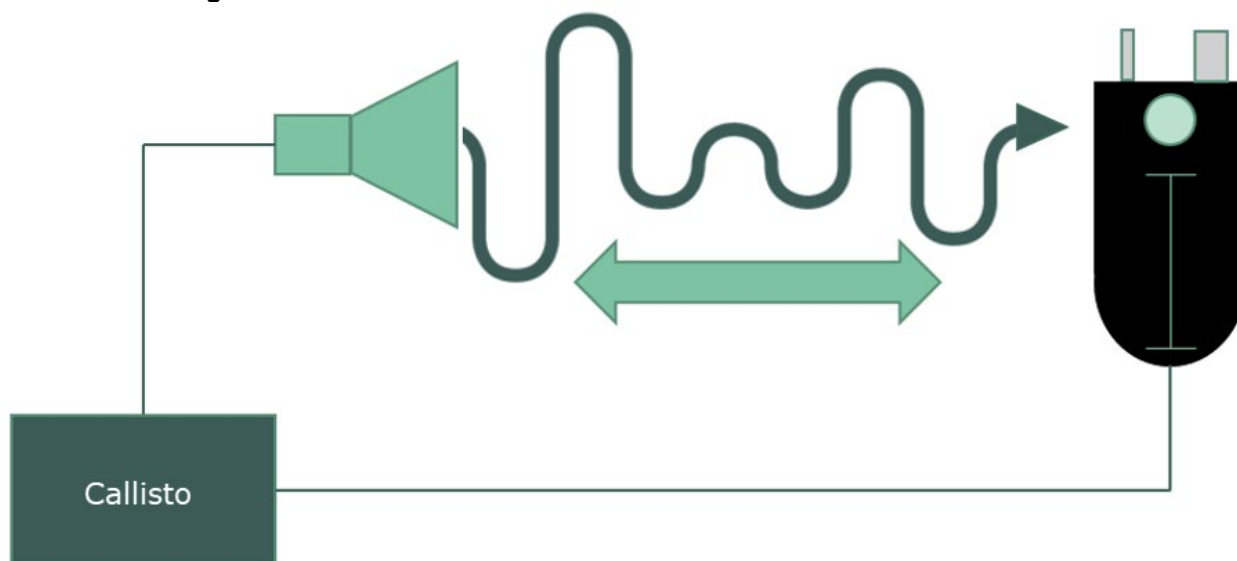

Referencing is the term used to describe the communication between the REM speaker and the Insitu REM headset reference microphone. This communication ensures that the stimulus level specified in the REM software is the correct stimulus level achieved at the patients' ear.

As an example, if the level specified in the software is set to 65dB and the REM speaker is playing at 55dB then the Insitu reference microphone will detect this and communicate to the speaker that it needs to increase the stimulus level by +10dB to achieve the specified stimulus level.

There are two different referencing procedures which can be performed using your Affinity Compact.



They are according to the following:

- **M**odified **P**ressure with **C**oncurrent **E**qualisation (MPCE)

This method actively monitors and controls the level of the REM stimulus as it is running. Therefore, if the stimulus level drops during the measurement the speaker will increase the intensity, so the correct level is applied.

This method is applied to the following signals:

- Pure Tone
- Warble
- Pink Noise
- White Noise
- NB Noise

- **M**odified **P**ressure with **S**tored **E**qualisation (MPSE)

This method performs the referencing process at the beginning of the measurement only and the level is set before the REM stimulus is played. This is done because the signals used for this method are complex and do not maintain the same frequency content at different time points.

Note: for signals which are being referenced by the MPSE method, the stimulus level will not increase/decrease should the level at the Insitu reference microphone not match that which is set in the software once the REM stimulus begins to play. It is because of this that you must maintain the patients' position during the measurement. The referencing procedure is still played before every stimulus though.

This method is applied to the following signals:

- International Speech Test Signal (ISTS)
- ICRA stimuli
- IF Noise
- Male Speech
- Female Speech
- Custom REM sound files

2.6.8 Vocal effort

We apply a vocal effort transform to our stimuli to result in a more life-like stimulation. When we apply these transforms, they are being supplied by the DSL algorithm.

Vocal efforts are included which results in the input level range being limited depending on the start level. If the measurement is set to start at for example a normal input level (e.g., 65 dB) the input levels slider can only be moved within normal vocal effort limits while measuring (40 – 70 dB). For a raised input level, the slider can be moved from 71 – 74 dB. If the measurement is set to start at a loud input level the slider can only be moved within 75 – 82 dB and if the measurement is set to a shout level the input level slider can be moved from 83 dB and above.



2.6.8.1 Presenting a stimulus

The REM440 stimuli can be selected from the main screen using the stimuli selection dropdown

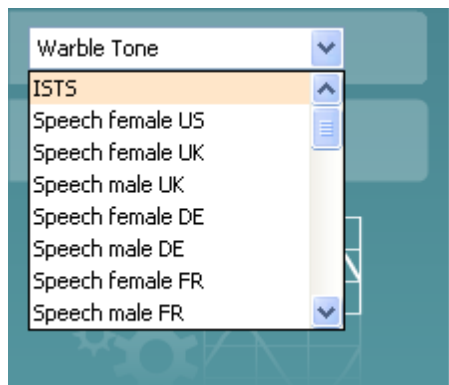

For continuous stimulus presentation, click the **continuous** button. When presenting continuously the curve may be frozen in a certain position using the **freeze** curve button:



Note: If you have done Calibrate for open fit, only the signals used for this calibration are available in the stimulus selection dropdown for aided measures (e.g., REIG, REAR)

2.6.9 Working with fitting targets

The REM440 includes many possibilities ensuring a precise target calculation based on the data available on the individual client.

2.6.9.1 Calculating the target

To show a target in the REM440 screen an audiogram must be present in the AC440/audiogram screen. This can be obtained in two ways:

- 1) Enter the AC440/Audiogram screen by clicking the **AUD** tab to the right and enter the thresholds manually while in **Current Session**.
- OR
- 2) If an audiogram has already been saved in Noah, it can be retrieved in the **Session List** where all historical audiograms are listed by date.

After selecting/entering an audiogram go to the REM screen.





2.6.9.2 Choosing a fitting prescription

Fitting targets can be selected in the *Fitting Prescription* dropdown list.

A fitting target can be described as a recipe for how to fit the hearing aids. Today, the most used generic fitting targets for non-linear hearing aids are the DSL *m[i/o]* developed at the University of Western Ontario in Canada and the NAL-NL1/NAL-NL2 developed by National Acoustics Laboratories in Australia.

The DSL *m[i/o]* is often used in paediatric fittings and has been verified on children. However, recent versions focus on adult fittings as well. The aim of the DSL *m[i/o]* is to provide the hearing aid user with an audible and comfortable signal at each frequency region. The knee-point is low allowing the client to perceive many soft sounds. This may be an advantage when using the input for speech development.

NAL-NL1/NAL-NL2 has a higher knee-point and focuses the amplification primarily on speech which is likely to be the most important reason for the client to acquire hearing aids. It aims to maximize speech intelligibility while maintaining overall loudness at a level like that perceived by a normal-hearing person listening to the same sound (Dillon 2001).

Note: the selections for each fitting prescription such as *Age*, *Client type* and so on differ depending on which fitting prescription is selected.

2.6.9.3 DSL *m[i/o]* options

Fitting prescription	
Name	DSL mi/o
Age	3 Years
Client type	Pediatric
Instrument	Behind the ear
Vent size	None
Transducer	Insert
Coupler	HA2 - Tip

Name: Select DSL *m[i/o]*. Note that it is version implemented is DSL *mi/o* v5.0a.

- *Age:* Age: Select the age of your client. This is relevant whenever a predicted RECD/REUR is used since these are highly dependent on ear canal size which varies across ages. Note that when the audiogram is measured with insert phones, the RECD is used in the conversion from dB HL to dB SPL. The RECD thereby influences the thresholds which will result in a target change.
- *Client type:* DSL *mi/o* v5.0a allows for selecting between a *Pediatric* or *Adult* prescription. The two prescriptions are based on the concept that adults and children with hearing loss have distinctly different preferences for listening level. The DSL *mi/o* v5.0a algorithm generates different prescriptions based on client age to take into consideration that adults and children not only require, but also prefer, different listening levels.

- *Instrument:* Select the type of hearing instrument your client is fitted with. This does not directly affect the target but the information is saved with the session.
- *Vent size:* Select the vent size your client is fitted with. This does not directly affect the target but the information is saved with the session.
- *Transducer:* Select the transducer used to obtain the hearing thresholds. The selected transducer will affect the threshold markings in the SPL-o-gram and thus the target calculation. Note the option to choose *ABR eHL* and *IA ASSR eHL*. ABR thresholds are assumed to be entered in eHL meaning that the system only corrects for the transducer. IA ASSR (Interacoustics ASSR system) corrects the audiogram simultaneously during the ASSR measurement. Therefore, the HL to SPL conversion from the REM440 module does not include a transducer correction. When the hearing aid fitting is based on an audiogram obtained with the Interacoustics ASSR, ensure that "IA ASSR eHL" is selected. this will ensure that double compensation is avoided.



- **Coupler:** Select the coupler type used for the RECD. The illustration below shows the different coupler types (Dillon 2001, pp. 77).

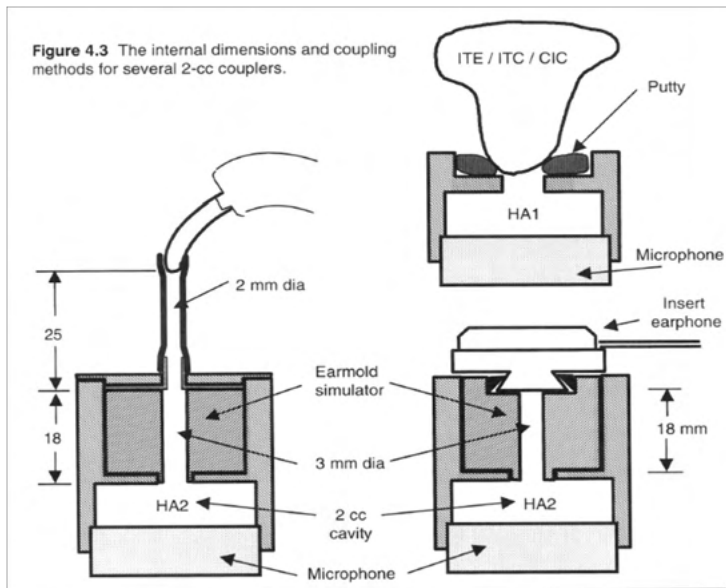

- **HA1 – Mold** refers using an RECD measured using the client’s own ear mold followed by 2cc coupler measures with an ITE adaptor.
- **HA1 – Tip** refers using an RECD measured using a foam tip or SPL probe followed by 2cc coupler measures with an ITE adaptor.
- **HA2 – Mold** refers using an RECD measured using the client’s own ear mold followed by 2cc coupler measures with a BTE adaptor.



- **HA2 – Tip** refers using an RECD measured using a foam tip or SPL probe followed by 2cc coupler measures with a BTE adaptor (the insert foam tip connects to the in-situ headset the same way as described for **HA2 – Mold** above).



Note: Remember to indicate the correct coupler type before performing the RECD based 2 cc coupler measures.



(For more information about the DSL mi/o v5.0a please refer to www.dslio.com) s



2.6.9.4 NAL-NL1/NAL-NL2 options

Fitting prescription

Name	NAL-NL2
Age	Adult
Gender	Unknown
User level	New user
Instrument	Behind the ear
Vent size	Occluded
Transducer	Insert

- **Name:** Select the *NAL-NL1* or *NAL-NL2*.
- **Age:** Select the age on your client. Research on children’s performance and preference leads us to infer that children on average prefer a few dB more gain than what NAL-NL1 prescribes (Ching et al. 2010). For this reason, the NAL-NL2 prescribes 5 dB more gain across frequency for children under 15 years of age compared to adults. Furthermore, selecting the correct age is important using a predicted RECD/REUR since these are highly dependent on ear canal size which varies across ages.
- **Gender:** Gender can be selected for NAL-NL2 only. Research has shown that males on average prefer 2 dB more gain than females with the same degree of hearing loss (Keidser & Dillon 2006). Consequently, gain is increased by 1 dB for males, and decreased by 1 dB for females.

- **User level:** If using NAL-NL2 indicate whether you are dealing with a *New user* or an *Experienced user*. Experienced hearing aid users have been shown to prefer more gain than people being fitted for the first time (Keidser et al., 2008). Thus, the NAL-NL2 decreases gain 4 dB for new hearing aid users.
- **Instrument:** Select the type of hearing instrument your client is fitted with. This does not directly affect the target but the information is saved with the session.
- **Vent size:** Select the vent size your client is fitted with. This does not directly affect the target but the information is saved with the session.
- **Transducer:** Select the transducer used when obtaining the hearing thresholds. The selected transducer will affect the thresholds and thereby corrections will be applied to the fitting target.

Note: The NAL-NL2 also distinguishes between *tonal* and *non-tonal* languages.

Gain at each frequency depends on importance of each frequency. Low frequencies are more important in tonal language. Tonal languages (such as Mandarin and Japanese) convey more information with the pitch of speech than do non-tonal languages (like English). Consequently, the low frequencies are given more gain for tonal languages than for non-tonal languages (Dillon et al. 2010). In the REM440 software NAL-NL2 targets will change accordingly when selecting a tonal stimulus in the stimulus selection (e.g., “Speech female JA”). Therefore, the system has no separate dropdown menu for this parameter.

(For more information on the NAL-NL2 prescription procedure please refer to Dillon et al. 2010)



2.6.10 Comparing to the hearing aid fitting software

Real-ear measures are often compared to the hearing aid manufacturer's software. You can run the REM440 and fitting software simultaneously within Noah4. If real-ear measures reveal too little or too much gain in some frequency areas, enter the fitting software and adjust gain using the relevant gain controls.

When comparing the measured real-ear curve to the hearing aid manufacturer's fitting software it is important keep in mind certain factors to have a valid comparison. Therefore, remember to check that the parameters used in the fitting software should be the same as in the REM440 module.

- 1) Ensure that the *curve type* is the same as simulated in the fitting software (e.g., do not compare an REAG in the REM440 to a REIG in the fitting software).
- 2) Ensure that the *stimulus* is the as close as possible to the stimulus simulated in the fitting software.
- 3) Ensure that the *input level* is the same as in the fitting software.
- 4) Ensure that the *fitting prescription* details in the fitting software are the same as used in the REM440 module.

2.6.10.1 On top mode

The *On top mode* button  converts the REM440 into an on top window that includes only the most essential REM features. It allows for changing *stimulus*, *input level*, *ear*, *continuous measurement*, and *Gain/Response view* only. The window is automatically placed on top of other active software programs such as the relevant hearing aid fitting software.

While adjusting the gain handles in the relevant fitting software, the REM440 screen will always stay on top of the fitting screen allowing for easy curve comparison.

To return to the original REM440 press the red cross in the upper right-hand corner .



2.6.10.2 Table mode

If graph comparisons are not preferred, you can choose the *Table mode* button . This may make it easier to compare the measured numerical values and the values in the hearing aid manufacturer's fitting software.

REUR/REUG	125	250	500	750	1000	1500	2000	3000	4000	6000	8000	100...
Predic...	2	5	6	6	8	15	19	18	14	7		

REAR/REAG	125	250	500	750	1000	1500	2000	3000	4000	6000	8000	100...
70 dB	-1	0	1	3	14	26	32	27	28	6	-1	
70 dB-T	-15	-5	0	6	12	22	30	28	26	24		
70 dB	-1	-1	1	2	18	24	31	30	27	5	3	
70 dB-T	-15	-5	0	6	12	22	30	28	26	24		

Calibrate for open fit	125	250	500	750	1000	1500	2000	3000	4000	6000	8000	100...
ISTS												

2.6.10.3 Show cursor on the graph

When comparing the graph in the fitting software to the graph in the REM440 the *Show Cursor on Graph* may be useful. Upon selecting the function, the cursor will highlight the curve and allow you to see the exact measured value at each frequency.

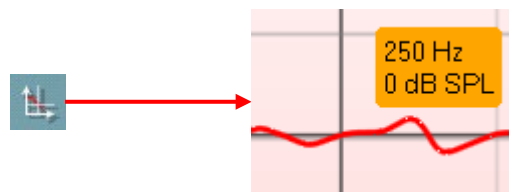

2.6.1 Speech Intelligibility Index (SII)

The Speech Intelligibility Index (SII) is a quality indicator of your hearing aid's fitting regarding the audibility it can provide.

The SII calculation will show the SII value as a percentage against the curve tag of every completed measurement for REUR, REUG, REAR, REAG and REIG in the bottom right corner.

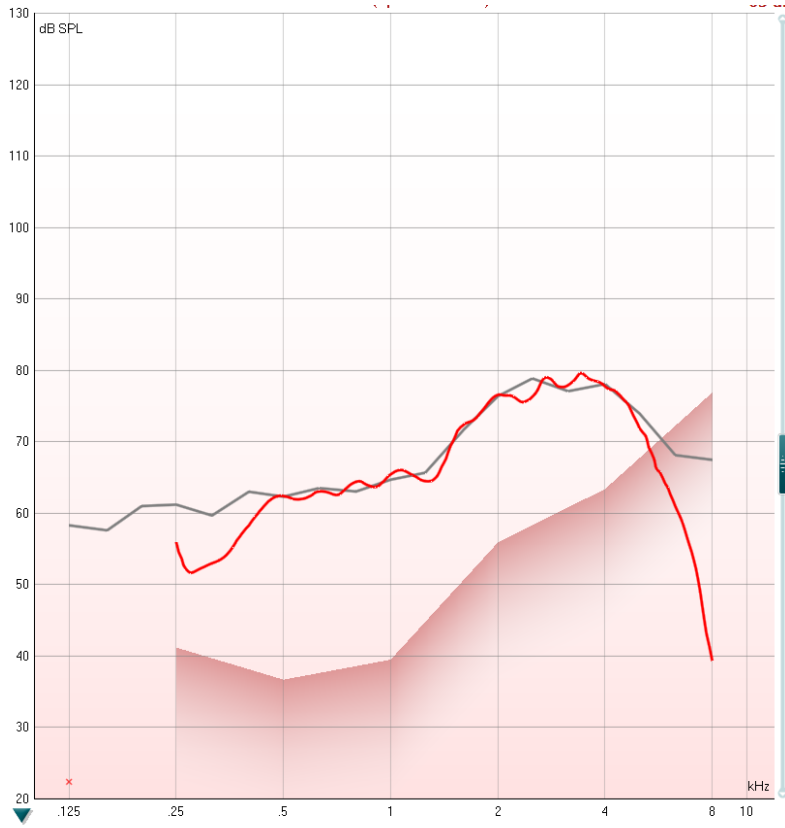

Gain view

Fitting prescription

Name	NAL-NL2
Age	9 Years
Gender	Male
User level	Experienced
Instrument	Behind the ear
Vent size	Open
Transducer	Head phone

Recorded method	FFT 1/3 Oct.
Input Level	65 dB SPL
Stimulus	ISTS
Measured in	Coupler
Coupler	2 cc (IEC 60318-5)
Curve type	Measured
Smoothing index	5

Curve comment

65 dB - SII: 86%

© Interacoustics®



2.6.2 Display peaks and valleys

If *Display peaks and valleys* is ticked for the REM test in the REM440 Setup you will have the view illustrated below. The peaks and valleys are shaped according to the LTASS.

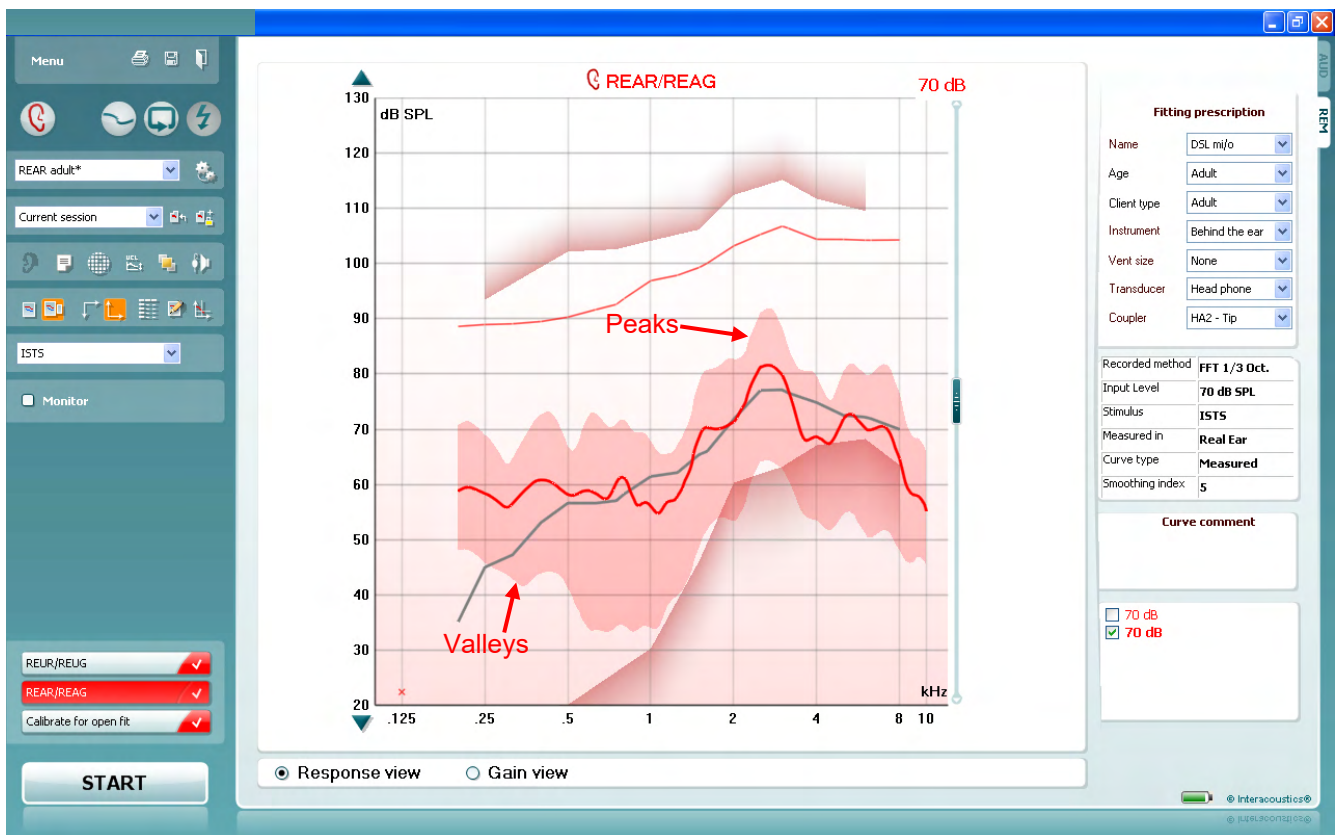

2.6.3 Preconditioning and sweep delay

Preconditioning and sweep delay can be set for each test in the REM440 settings (see section 2.8.2)

2.6.3.1 Preconditioning

Preconditioning is relevant when using broadband signals for example ISTS/ICRA. It consists of a **wideband signal followed by a pure tone just before the selected stimulus is presented.**

The precondition function allows you to set a certain time before the curve is shown on screen. This will allow the hearing aid algorithms to have time to switch on and stabilise. This has two effects – first you will avoid the hearing aid being in the process of changing characteristics during the test, and secondly, the hearing aid will in this case be brought into the mode corresponding to the non-linear stimulus.

2.6.3.2 Sweep delay

The sweep delay is the time before the next sweep will start when running a continuous measurement using Pure Tone or Warble Tone. Modern hearing aids often have advanced algorithms that require a certain reaction time. It is therefore helpful to be able to set individual delays.



2.6.4 Smoothing a curve

Smoothing is a technique where small details in the curve appear to be ironed out. As these details sometimes have a noisy character, smoothing may be preferred. The individual tests can be designed to have smoothing applied in the REM440 setup. Smoothing is applied according to a $n/12$ octave smoothing method. Whereby the lower smoothing value delivers a higher curve resolution due to inclusion of more data points.

Smoothing can also be applied after measuring in two ways:

- Shift + up/down arrow keys on the PC keyboard
- Shift + the scrolling wheel on the mouse

Examples:

Smoothing Index 0

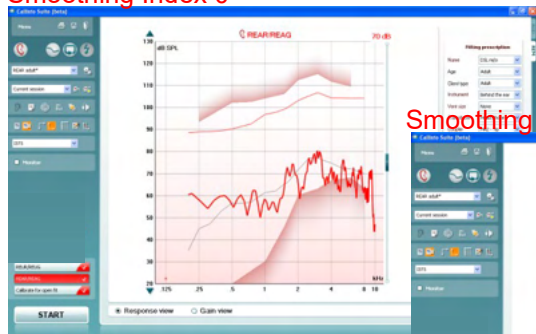

Smoothing Index 10



Smoothing Index 5

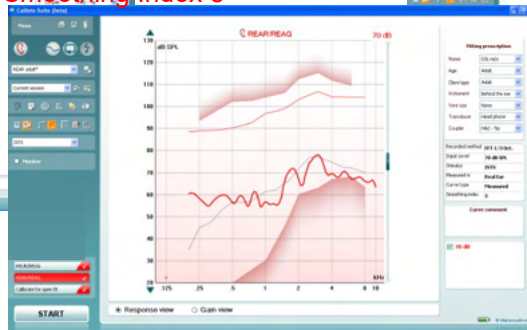

2.6.5 Comparing curves

The REM440 also allows for comparing either two historical curves (e.g., two REIG curves) or comparing a historical curve to a currently recorded curve. This may be helpful when having adjusted a hearing aid to see if the new setting is closer to the target. It may also be helpful if fitting two different hearing aids to see which one matches the target better.

Note: The *Age* dropdown list in the Fitting Prescription will not change when going into a historical session. However, target information viewed in the historical session will be based on the audiogram used when the session was saved.

Compare curves as follows:

1. Find the first curve in the *Session list*. Historical real-ear measures are listed by date and time when saved.

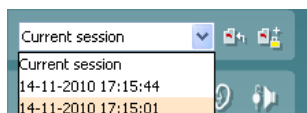

2. Press *Toggle between lock and unlock the selected session*



3. Find the second curve in the *Session list*. This can be either a curve of the current session or a historical curve.

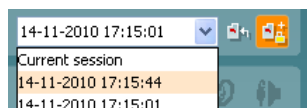



The two curves are now shown



Note: To avoid error through incorrect comparison, only curves of the same type can be compared! This function is embedded into the system so that you do not need to focus on this and to prevent comparing mistakes.

2.6.6 Managing multiple curves

If measuring many curves during the same test session, there are several ways to provide a simpler view or a comparison view showing only the preferred curves on the same graph.

2.6.6.1 Curve display options

In the curve display options box, all curves are listed by input level and color.

If many of the same curve type (e.g., REIGs) have been measured tick only the ones that you wish to display on the graph.



Un-ticked curves will be hidden ensuring a less confusing screen view.



2.6.6.2 Deleting curves

To delete one or all curves right click on the input level marking in the curve display options box. Select *Delete* to remove the selected curve or *Delete all* to remove all curves displayed in the graph.

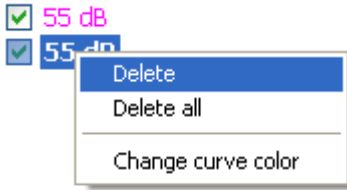

2.6.6.3 Combined screen view

If a combined screen is setup you may want to compare to other curves obtained. Press the corresponding button to toggle between single and combined screen:



In the combined screen setup, you can decide exactly which curves are to be compared so that pressing the combined screen button results in comparing multiple REAR or REIG measures (see section 2.8.3 for how to do a combined screen setup).

2.6.6.4 Changing the curve color

If having many curves on screen you can change their colors even after they are measured. Right click on the preferred curve and choose *Change curve color*. The system will then allow for choosing a new color.

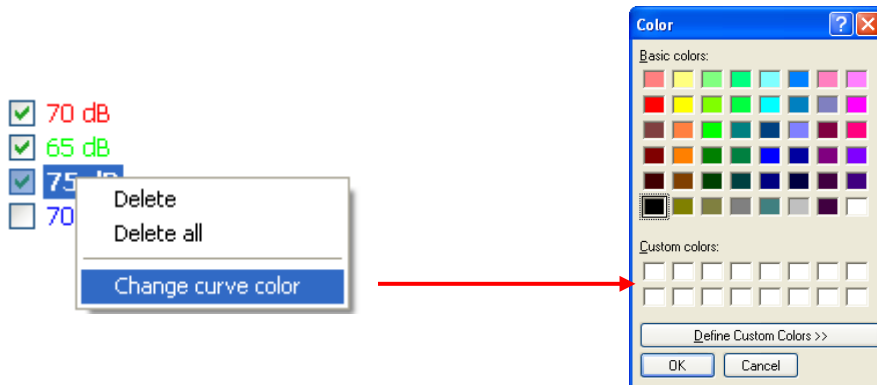



2.7 Clinical application of real-ear measurements using REM440

This section describes all the REM440 real-ear tests. For all measures, please reduce ambient noise as much as possible.

2.7.1 REUR/REUG measurements

REUR (Real-Ear Unaided Response): The REUR accounts for the SPL across frequencies measured in the open/unaided ear canal for a given input signal at specific measurement point.

REUG (Real-Ear Unaided Gain): The REUG accounts for the gain in the unaided ear canal provided solely by the auricle and ear canal. This is obtained by subtracting the input level from the REUR.

$$\text{REUR} - \text{input} = \text{REUG}$$

The REUR/REUG is used in the calculation of REIG (Real-Ear Insertion Gain)

The REUR/REUG may also help reveal irregularities in the ear canal. In cases of temporal surgery, for example mastoidectomy, the residual ear canal volume may be much larger than in an average ear.

Note: REUR is also known as an Open Ear Response

Test procedure:

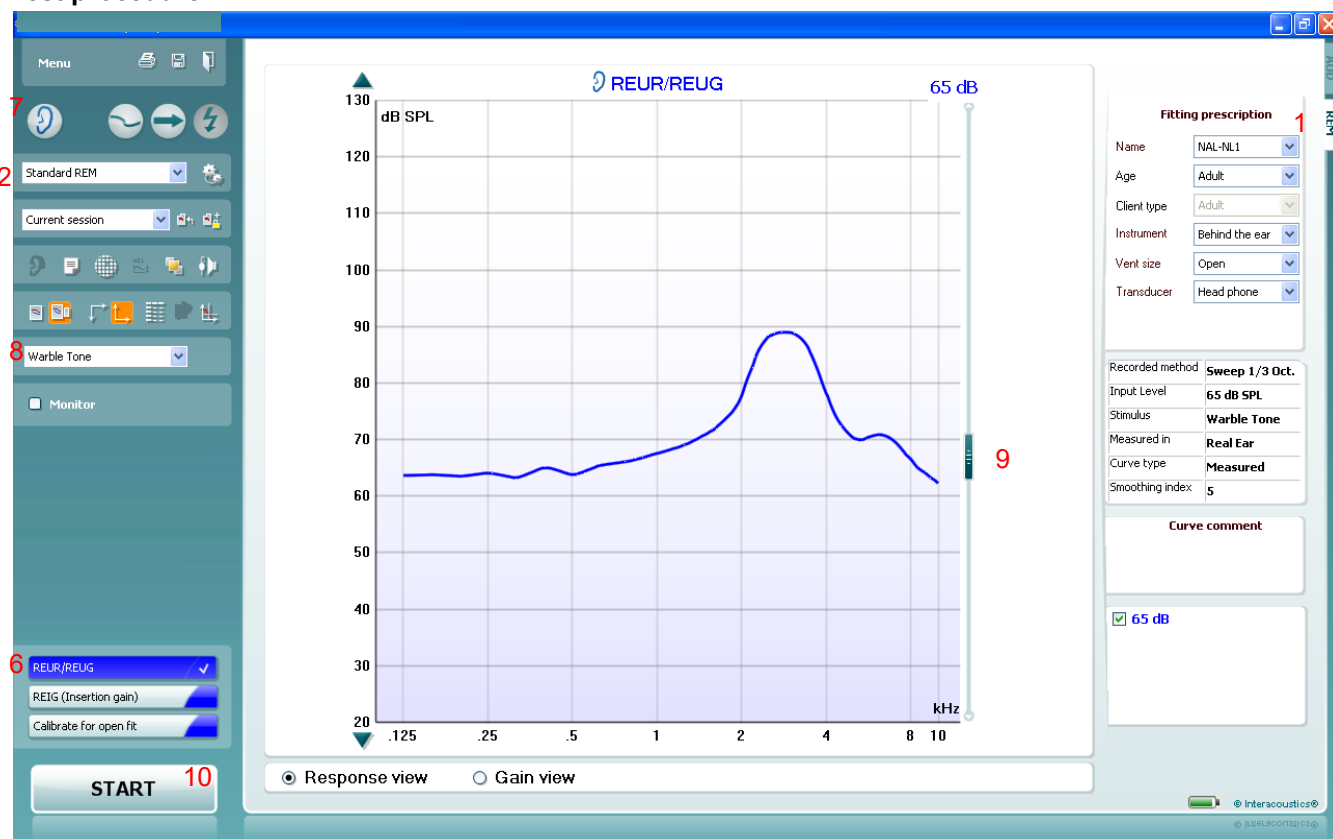

- 1) Open the REM440 module by selecting the REM tab.
- 2) If needed select a test protocol in the **List of Protocols**. If you do not select a protocol the system will automatically select a standard protocol.
- 3) Explain the procedure to the client.
- 4) Perform an otoscopic examination.
- 5) Mount the probe tube on the in-situ headset and place it on the client who should be seated ½-1 meters from the speaker.
Ensure that the probe tubes are calibrated before placing them in the ear canal (see section 2.6.2 about tube calibration).



6) Click on the **REUG/REUR** button if it is not already marked automatically.
A right click on REUG/REUR button allows you to enter the *Settings* menu, *Show a predicted curve*, or *Change color* of the curve.

7) Ensure that the correct **Ear** is selected



corresponding dropdown list

8) Choose the preferred **Stimulus** in the



9) Select input level using the Input level slider

10) Click **START** and the REUR/REUG will be performed.

Ensure that the room is quiet whilst the curve is obtained

11) If you wish to use the REUG/REUR for both ears, right click on the curve tag in the Curve display options and select *Transfer to left/right ear*.

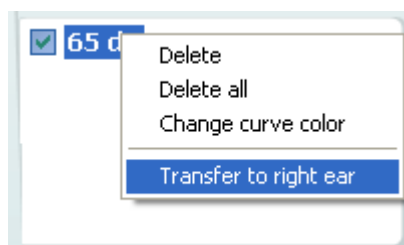

Note: If running the hearing aid manufacturers fitting software as well, the curve may be saved in Noah4 and retrieved in the fitting software. The fitting target will then be recalculated based on the individual ear canal resonance. These options, however, differ from manufacturer to manufacturer and will therefore not be outlined in this manual.



2.7.1.1 Predicted REUR

When right clicking on the REUG/REUR as described in point 6 above you may choose to use a predicted curve. This may be helpful if having to deal with challenging clients. When clicking *Show predicted curve* the screen below will appear:

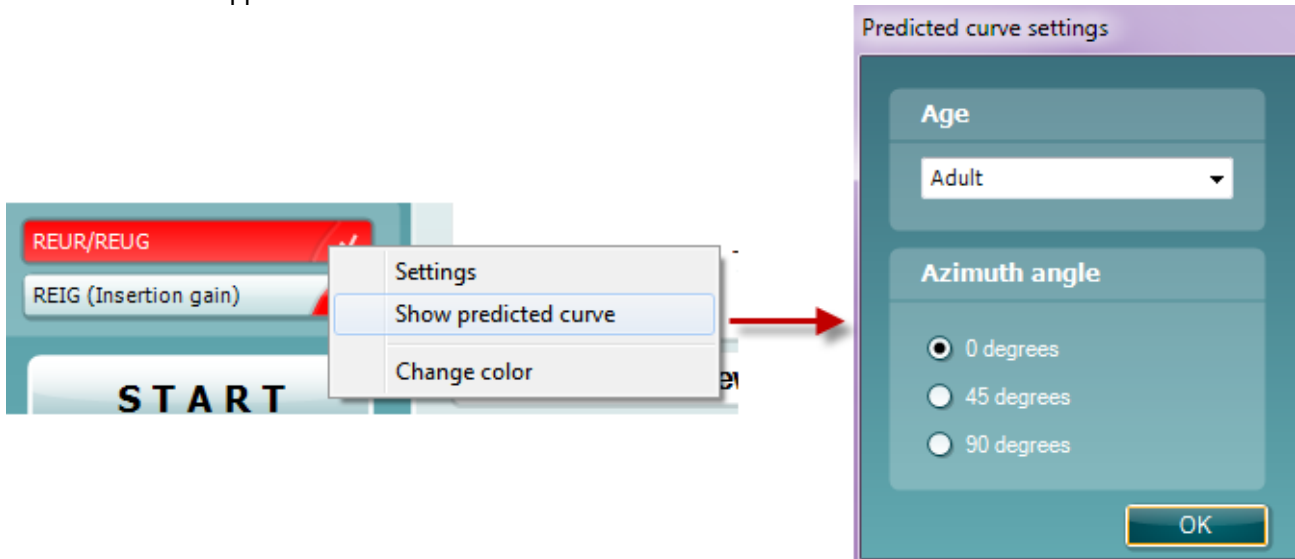

Choose **Age** and **Azimuth** angle and click OK.

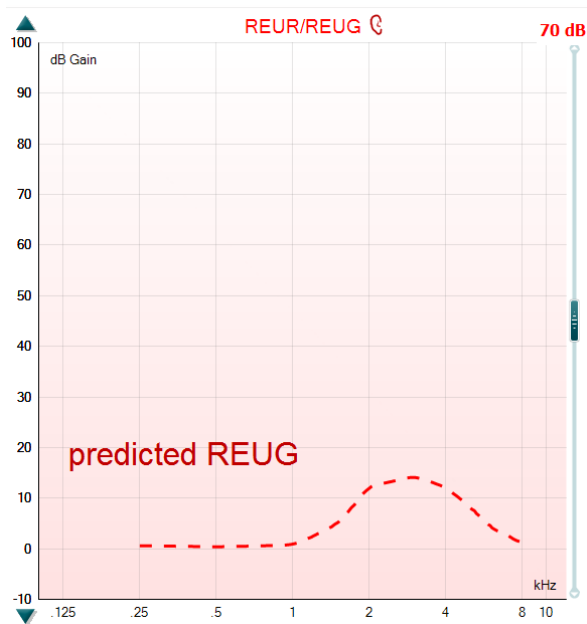



2.7.1.2 REUG/REUR from a previous session

If you have measured the REUG/REUR at an earlier session with the client, the REM440 provides the option to use this historical curve in the current session.

- 1) Browse for the historical REUG/REUR curve in the session browser:

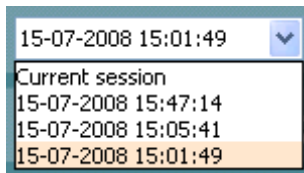

- 2) Right click on the curve tag in the *Curve display options*:

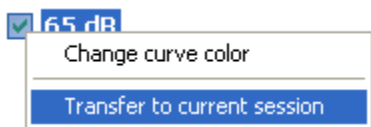

- 3) Select *Transfer to current session*. The curve will be automatically appear in the current session.

2.7.1.3 REUR/REUG in both ears view

If you wish to compare the REUR/REUG for left and right this can be done by right clicking on the **Ear** icon.

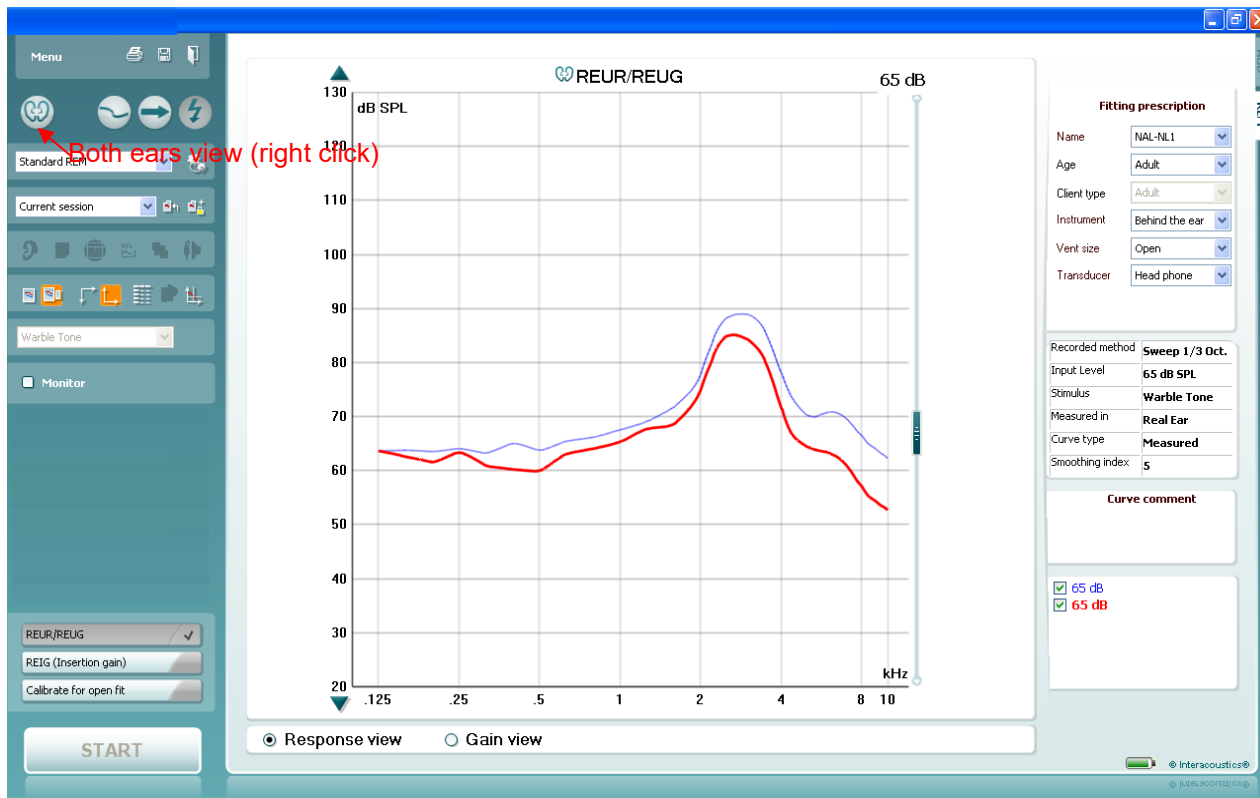



2.7.2 REAR/REAG measurements

REAR (Real-Ear Aided Response): The REAR accounts for the SPL across frequencies for a given signal measured in the ear canal with the hearing aid in place and turned on.

REAG (Real-Ear Aided Gain): The REAG accounts for the gain across frequencies for a given input signal measured in the ear canal. This is obtained by subtracting the input level from the REAR.

$$\text{REAR} - \text{input} = \text{REAG}$$

The REAR/REAG is used in the calculation of REIG (Real-Ear Insertion Gain). Furthermore, some fitting prescriptions (such as DSL $m[i/o]$) prescribe REAR/REAG targets for some input levels. If the audiogram has been converted from dB HL to dB SPL and uses a SPL-O-GRAM, it can quickly be determined whether an input is audible or not.

Test procedure:



- 1) Open the REM440 module by selecting the REM tab.
- 2) If needed select a test protocol in the **List of Protocols**. If you do not select a protocol the system will automatically select a standard protocol.
- 3) Explain the procedure to the client.
- 4) Perform an otoscopic examination.
- 5) Mount the probe tube on the in-situ headset and place it on the client who should be seated ½-1 meters from the speaker.
Ensure that the probe tubes are calibrated before placing them in the ear canal (see section 2.6.2 about tube calibration).
- 6) Carefully insert the hearing aid without moving the probe tube. Ensure that the instruments are switched on.
- 7) If fitting an open hearing aid, perform **Calibrate for open fit** (see section 2.6.4).
- 8) Click on the **REAG/REAR** button if it is not already marked automatically.
A right click on REAG/REAR button allows you to enter the *Settings* menu or *Change color* of the curve.



- 9) Check that the information about client, fitting prescription and hearing aid parameters to the right are correct.
- 10) Ensure that the correct **Ear** is selected
- 11) Choose the preferred **Stimulus** in the corresponding dropdown list
If you have done Calibrate for open fit only the signals used for this calibration are available in the stimulus selection dropdown (see section 2.6.4).



- 12) Select input level using the Input level slider
- 13) Click **START** and the REAG/REAR will be performed.
Ensure that the hearing aids are switched on and that the room is quiet whilst the curve is obtained.

Note: An REAR90 is added when DSL $m[i/o]$ is selected under *Fitting Prescription*. Furthermore, a speech banana using the unamplified speech spectrum from DSL can be viewed by right clicking on the graph. This is, however, only possible for REAR measurements.

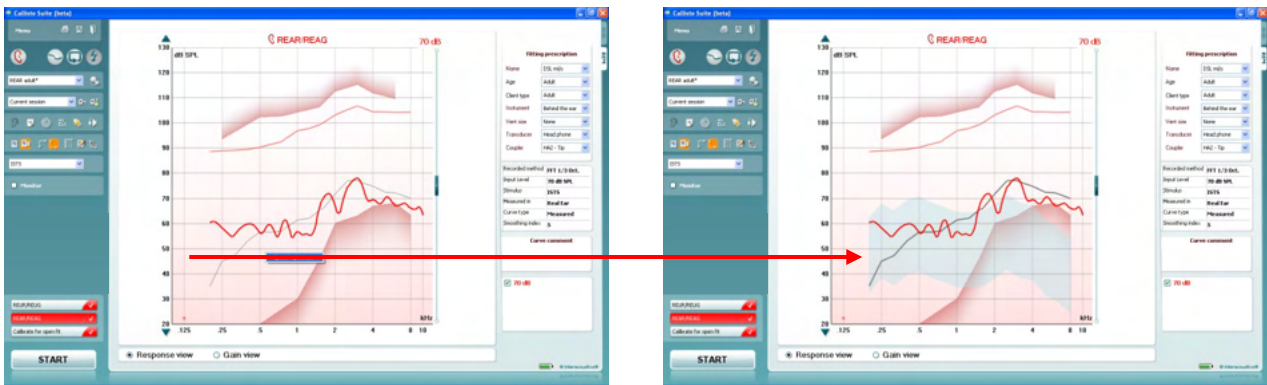



2.7.3 REIG measurements

REIG (Real-Ear Insertion Gain): The REIG accounts for the gain across frequencies provided by the hearing aid alone. This is obtained by subtracting the REUR from the REAR or the REUG from the REAG.

$$\text{REAR} - \text{REUR} = \text{REIG}$$

The REIG is most often used to verify if a given hearing aid setting is providing an acceptable level of gain compared to the prescribed REIG target.

Test procedure:



- 1) Open the REM440 module by selecting the REM tab.
- 2) If needed select a test protocol in the **List of Protocols**. If you do not select a protocol the system will automatically select a standard protocol.
- 3) Explain the procedure to the client.
- 4) Perform an otoscopic examination.
- 5) Mount the probe tube on the in-situ headset and place it on the client who should be seated ½-1 meters from the speaker.
Ensure that the probe tubes are calibrated before placing them in the ear canal (see section 2.6.2 about tube calibration).
- 6) Measure the **REUG/REUR** (see section 2.7.1) or select a predicted REUG/REUR (see section 2.7.1.1).
Note: Since the REIG is a calculation the system will require that you perform the REUR before performing the REIG.

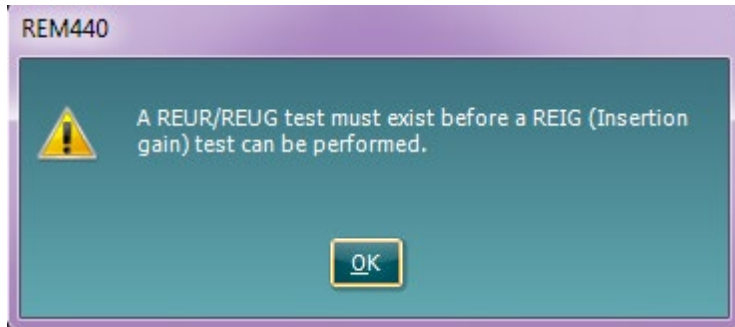

- A predicted REUR may be selected if the REUR is a part of the individual test protocol (see section 2.8.2.1).
- 7) Carefully insert the hearing aid *without moving the probe tube*. Ensure that the instruments are switched on.
 - 8) If fitting an open hearing aid; perform **Calibrate for open fit** (see section 2.6.4).
 - 9) Click on the **REIG** button if it is not already marked automatically.
A right click on REIG button allows you to enter the *Settings* menu or *Change color* of the curve.
 - 10) Check that the information about client, fitting prescription and hearing aid parameters to the right are correct.
 - 11) Ensure that the correct **Ear** is selected 
 - 12) Choose the preferred **Stimulus** in the corresponding dropdown list
If you have done Calibrate for open fit only the signals used for this calibration are available in the stimulus selection dropdown (see section 2.6.4).



- 13) Select input level using the Input level slider
- 14) Click **START** and the REIG will be performed.
Ensure that the hearing aids are switched on and that the room is quiet whilst the curve is obtained.



2.7.4 RECD measurements

Please see Appendix 2 for instructions on how to connect the TBS10 test box to the Callisto™ for use for RECD measurements.

RECD (Real-Ear to Coupler Difference): The RECD accounts for the difference in decibels (dB) across frequencies, between the SPL measured in the real-ear and in a 2cc coupler, produced by a transducer generating the same signal.

Example at 1000 Hz:

$$\text{Coupler SPL} - \text{Real-Ear SPL} = \text{RECD}$$

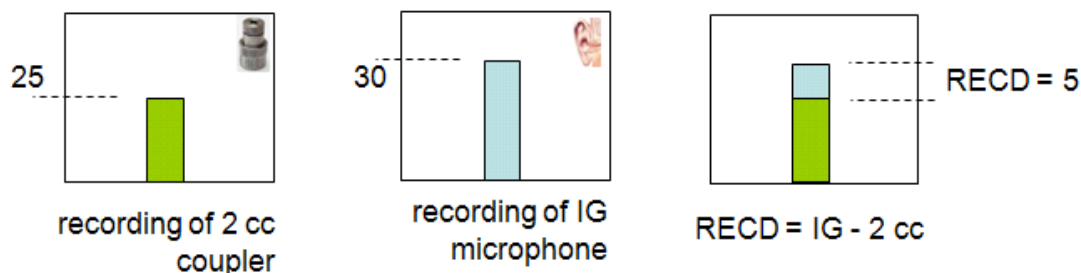

In this example 25 dB SPL is measured in the 2 cc coupler and 30 dB SPL was measured in the ear. This means that we have a real-ear to coupler difference of 5 dB SPL at 1000 Hz.

COUPLER MEASURE



EAR MEASURE



You are performing a measurement to compare two entities a known volume size (the coupler) and an unknown volume size (the ear canal). This is important to do with clients whose ear canals are not the standard 2cc in volume. For example, children or adults who have had surgical procedures. The difference measurement obtained between the ear and coupler provides individual information about the ear canal which can be used in the hearing aid fitting. It can be utilized to estimate 2cc coupler targets which means you can not only test on the ear but also based on the RECD values the verification can be performed in the test box instead of the client's ear. This is particularly useful with children.

Note: When an RECD is measured the REM440 automatically switches to test box/coupler verification mode (simulated REM).



The REM440 module provides a guided RECD procedure making sure no mistakes are made.

There are two ways to measure RECD which will be described in this section:

- a) RECD with the client's own ear mould
- b) RECD with an SPL probe

Right click on the RECD test in the protocol list and select *Settings* to check if the system is setup to use the client's own ear mould or SPL probe for the RECD.

To use the SPL probe tick Use Insitu SPL probe. If this box is not ticked the system will assume that you are using the client's own ear mold.

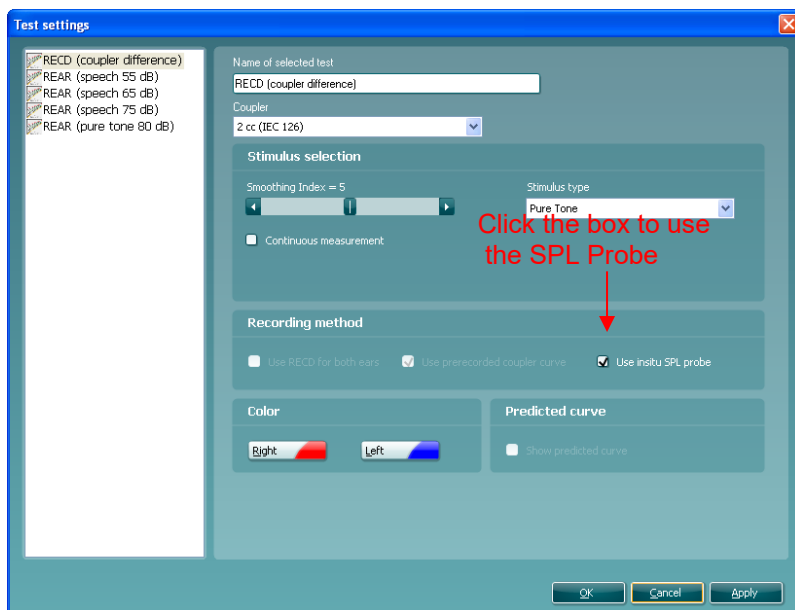
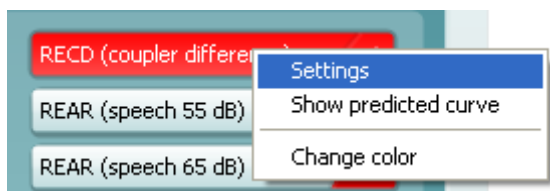



2.7.4.1 RECD using the client's own ear mould

Additional required items:

- An ear mould
- A 2 cc coupler connected to an adaptor for the BTE. These click easily together.

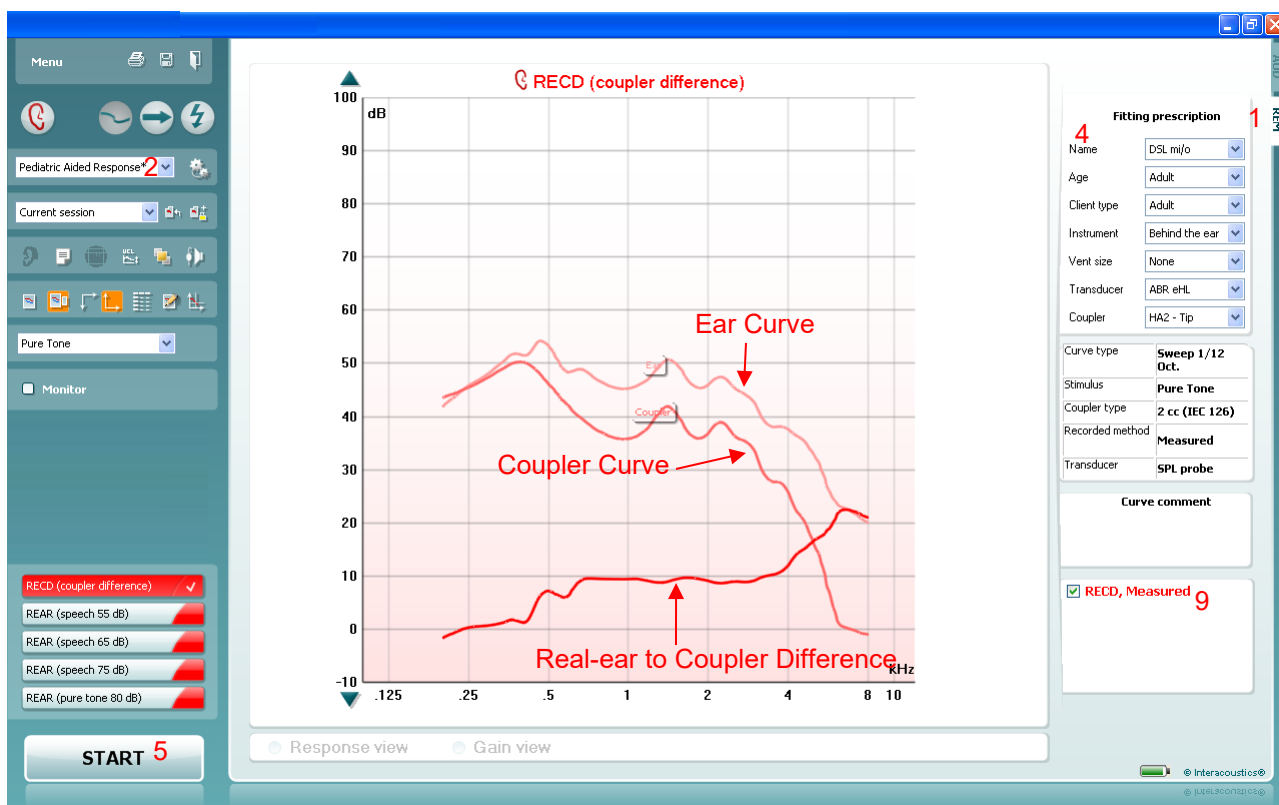

- 1) Open the REM440 module by selecting the REM tab.
- 2) Select a test in the **List of Protocols**.
- 3) The RECD is most often used with children, so you will need to explain the procedure to the parents.
- 4) Ensure that the information about client, fitting prescription and hearing aid parameters to the right are correct.
- 5) Click **START** and the screen below will appear.

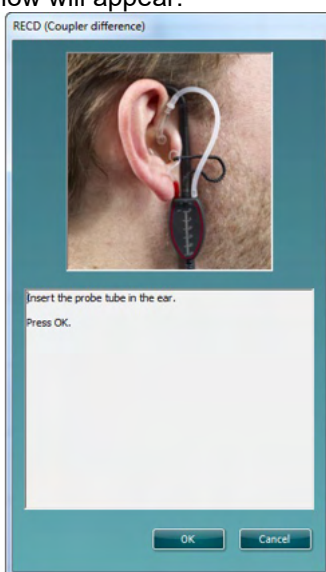
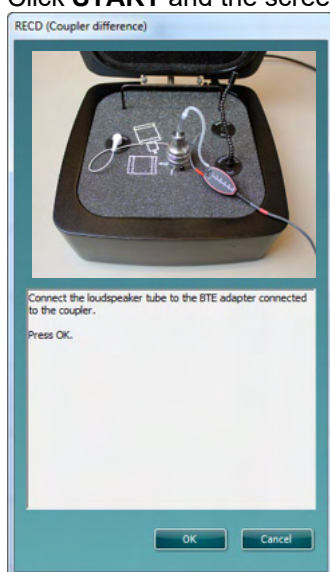



- 6) Connect the tube to the BTE adapter as shown on the picture and click **OK**. The coupler curve will be performed followed by a new instruction screen.
- 7) Disconnect the sound tube from the BTE adapter and connect it to the ear mould. Perform otoscopy and insert the REM probe and ear mould as shown on the picture. You may wish to use the slide-on ear loop which provides an easier fit. Press **OK** and the ear curve will be conducted.
- 8) The measured curves are shown as:
 - Recorded Ear curve
 - Recorded Coupler curve
 - RECD curve
- 9) If you wish to use the RECD for both ears, right click on the curve tag in the Curve display options and select *Transfer to left/right ear*. You may also set setup the RECD to be transferred to the opposite ear by default (see section 2.8.2.4)



Note: The RECD is performed at a fixed input level of 70 dB and cannot be adjusted by the user.



2.7.4.2 RECD using the SPL probe

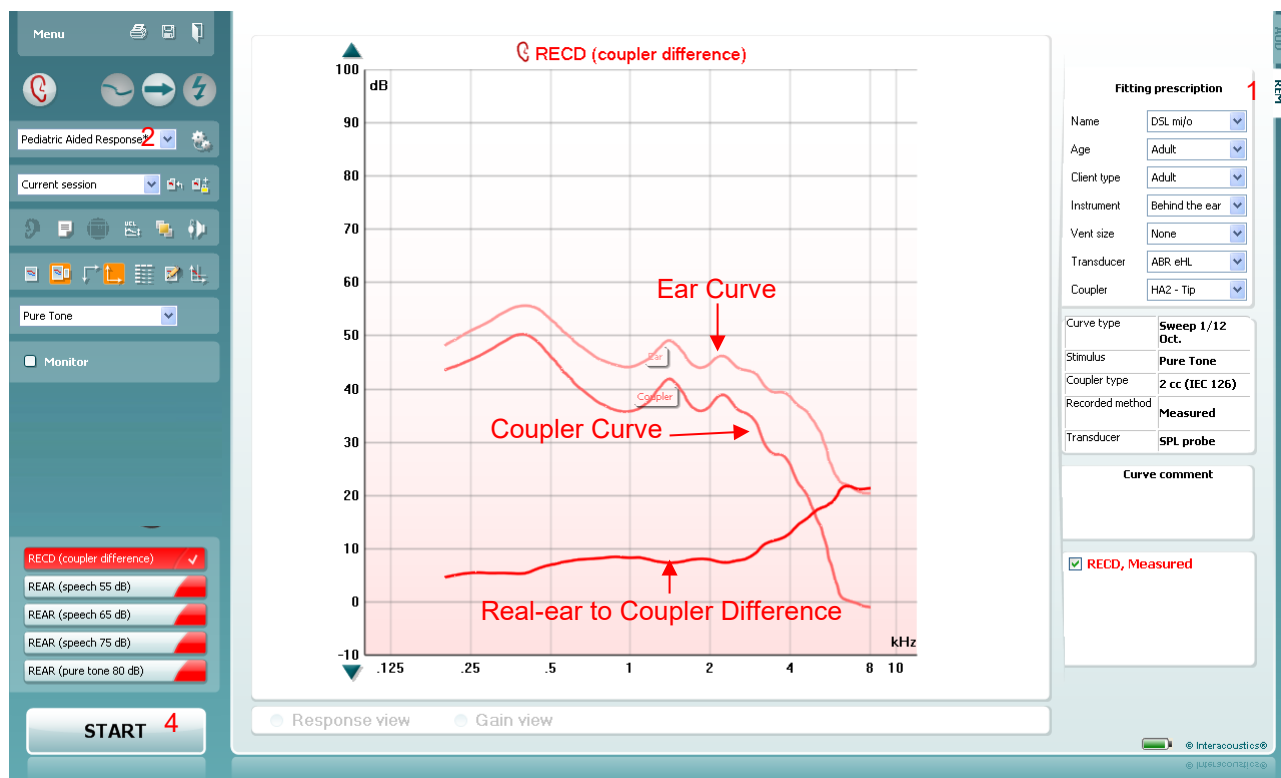

Additional required items:

- An SPL probe and ear tips.



- A 2 cc coupler connected to an adapter for the SPL probe. These click easily together.

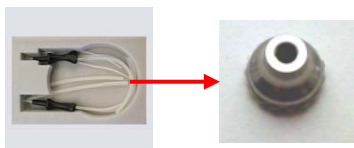

Note: Remember to calibrate the SPL probe.

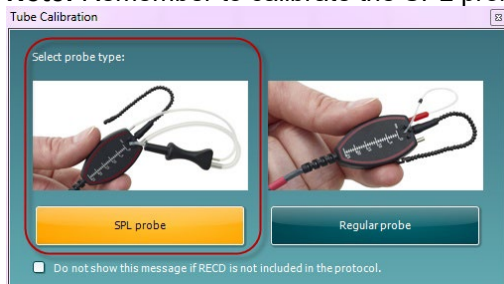

- 1) Open the REM440 module by selecting the REM tab.
- 2) Select a test in the **List of Protocols**.



- 3) The RECD is most often used with children, so you will need to explain the procedure to the parents.
- 4) Click **START** and the screen below will appear.

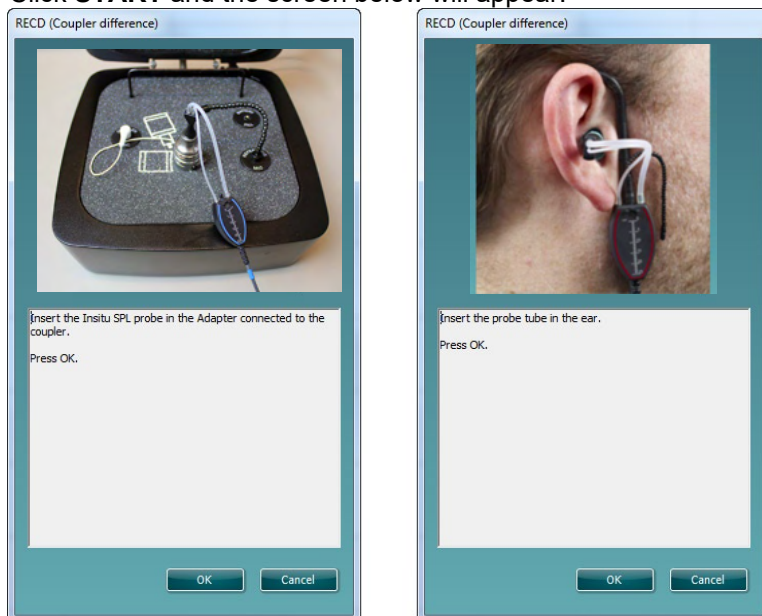

- 5) Connect the tube to the BTE adapter as shown on the picture and click **OK**. The coupler curve will be performed followed by a new instruction screen.
- 6) Disconnect the sound tube from the SPL probe adapter and perform otoscopy before placing the SPL probe in the client's ear.
Remember to attach the ear tip to the SPL probe prior to inserting the probe and connect it to the SPL probe.
Press **OK** and the ear curve will be conducted and shown on the screen as below.
- 7) The measured curves are shown as:
 - Recorded Ear curve
 - Recorded Coupler curve
 - RECD curve
- 8) If you wish to use the RECD for both ears, right click on the curve tag in the Curve display options and select *Transfer to left/right ear*.
You may also configure the RECD to be transferred to the opposite ear by default (see section 2.8.2.4)

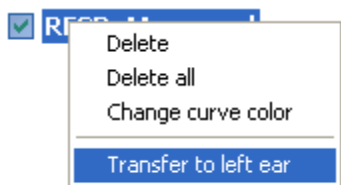

Note: The RECD is performed at a fixed input level of 70 dB and cannot be adjusted by the user.



2.7.4.3 Own mould versus SPL probe

Whether the RECD is performed using the client's own ear mould or the SPL probe may influence the result. The benefit of using the client's own ear mould is that the measurement will reflect your client's actual residual volume when wearing their hearing device whereas the SPL probe only provides an estimate. However, you may be in a situation where the mould is non-existent, broken, or has an extremely bad fit. Furthermore, you might need to conduct measurements on children not willing to co-operate. In these situations, the SPL probe offers the benefit of easy probe placement and measurement. Below see two RECD measured in the same ear using the SPL probe and own ear mould respectively.

Note: the differences between the two ways of measuring. As can be seen above the curve measured with the client's own ear mould is below 0 in the low frequencies. This may be due to ear mould effects such as the tightness of the fit and venting and in the insertion depth of the SPL probe or ear mould.

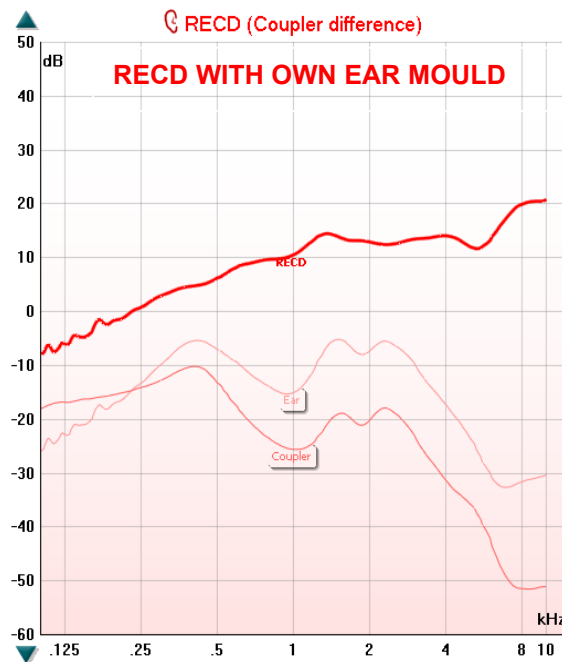
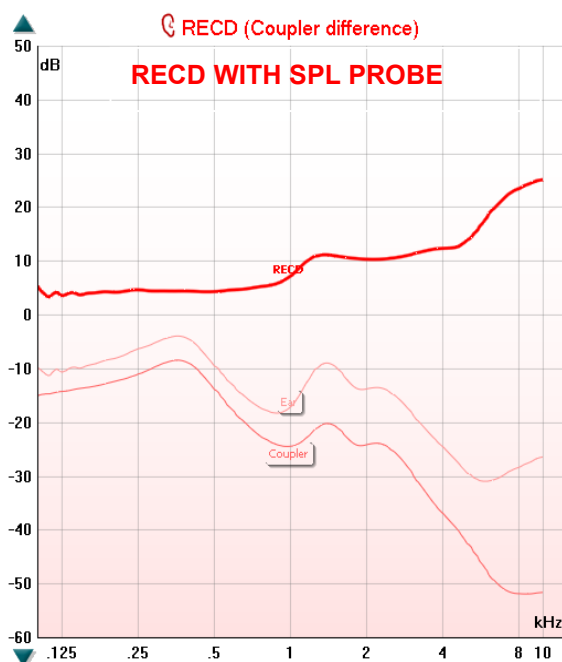

2.7.4.4 Predicted RECD curve

Right click on the RECD in the protocol list to use a predicted curve. Select *Show predicted curve* and the screen below will appear:

Choose the **Age** and **Azimuth angle** using the dropdown lists.

The dialog box is titled "Predicted curve settings". It contains three sections: "Age" with a dropdown menu set to "3 Years"; "Coupler type" with a dropdown menu set to "HA2 - Tip"; and "Azimuth angle" with three radio button options: "0 degrees" (selected), "45 degrees", and "90 degrees". An "OK" button is located at the bottom right of the dialog.



2.7.4.5 Measured RECD compared to a predicted RECD

You can at any time select a predicted RECD as described in section 2.7.4.4 and view it alongside a measured RECD. Note that when both a measured and a predicted RECD are displayed the system will always prioritize the measured RECD for the test box verification (simulated REM). If you wish to use the predicted RECD the measured curve must be deleted.

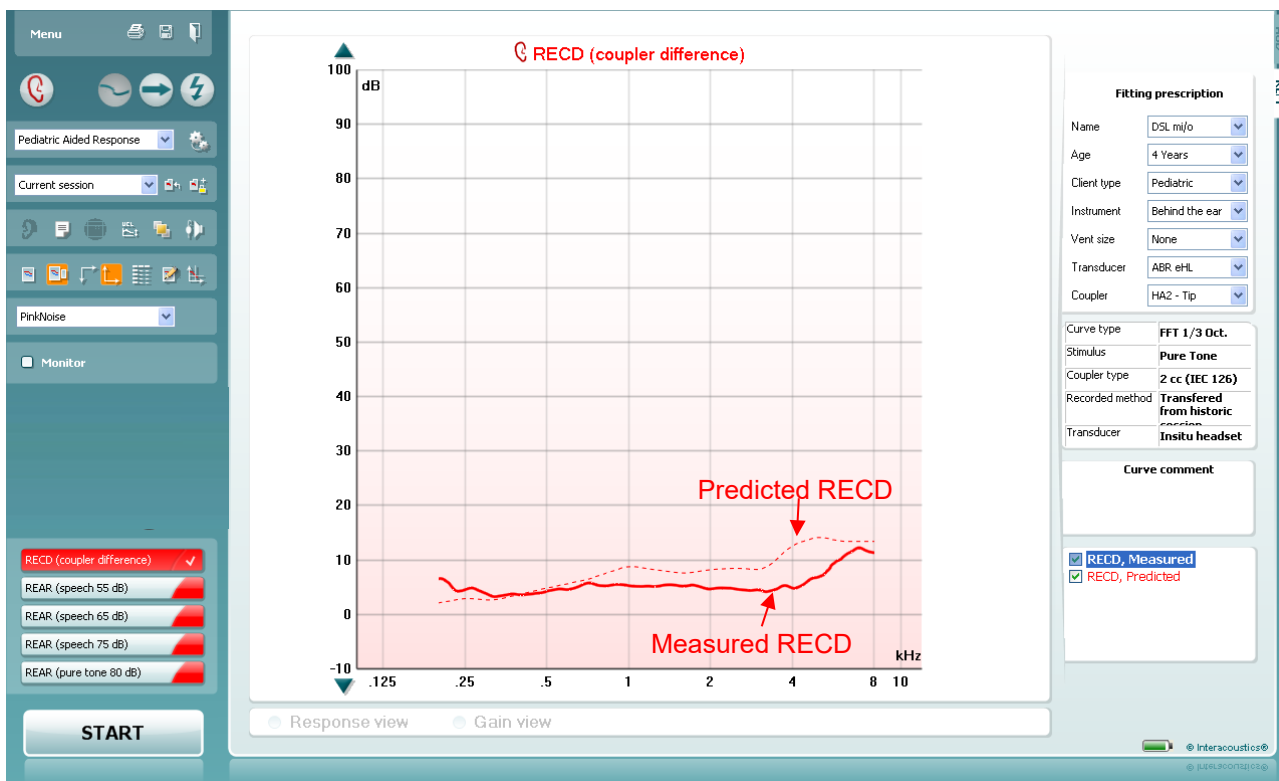

2.7.4.6 Re-using a coupler curve

If you prefer to use a pre-recorded coupler curve this can be setup in the *Settings* menu for RECD in the REM440 setup (see section 2.8.2.4).

When ticking *Use pre-recorded coupler curve* the latest coupler curve will automatically appear on the graph

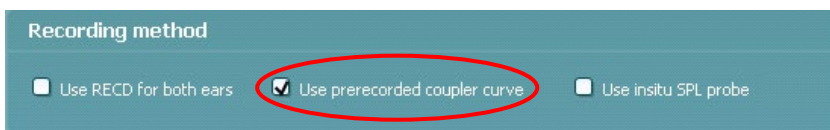

which means that the clinician only needs to perform the ear measure.

Note: This is only possible when using a Pure Tone stimulus.



2.7.4.7 RECD from a previous session

If you have measured the RECD at an earlier session with the client, the REM440 provides the option to use this historical curve in the current session.

- 1) Browse for the historical RECD curve in the session browser:

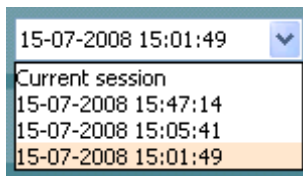

- 2) Right click on the curve tag in the Curve display options

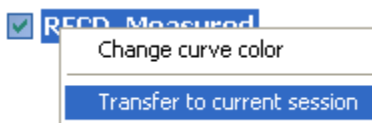

- 3) Select *Transfer to current session*. The curve will then automatically appear in the current session.

2.7.4.8 Test box/coupler base fitting (simulated REM)

By clicking on the **Toggle between Coupler and Ear** button in the front screen after performing the RECD you may choose to continue your fitting using either the:

- a) “Coupler approach” (simulated REM) in the test box/coupler base, or
- b) In the Real-ear

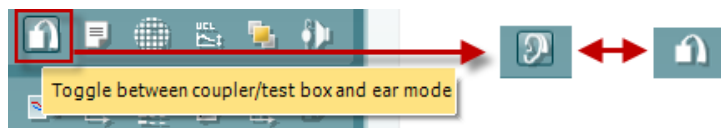

2.7.4.9 The “coupler approach”

When an RECD is present (measured, predicted, or transferred it from a historical session) the system will automatically switch to coupler mode for the REAR/REIG measures.

- 1) Select REIG or REAG/REAR.

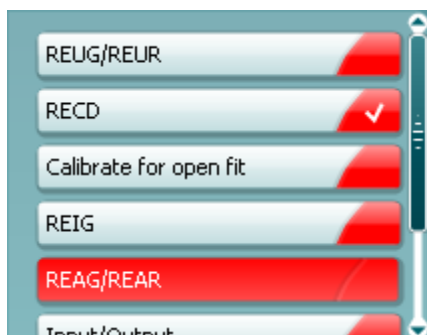

- 2) Position the hearing aid in the test box/coupler base with the reference microphone placed in the same acoustical point as the microphone in the hearing aid.



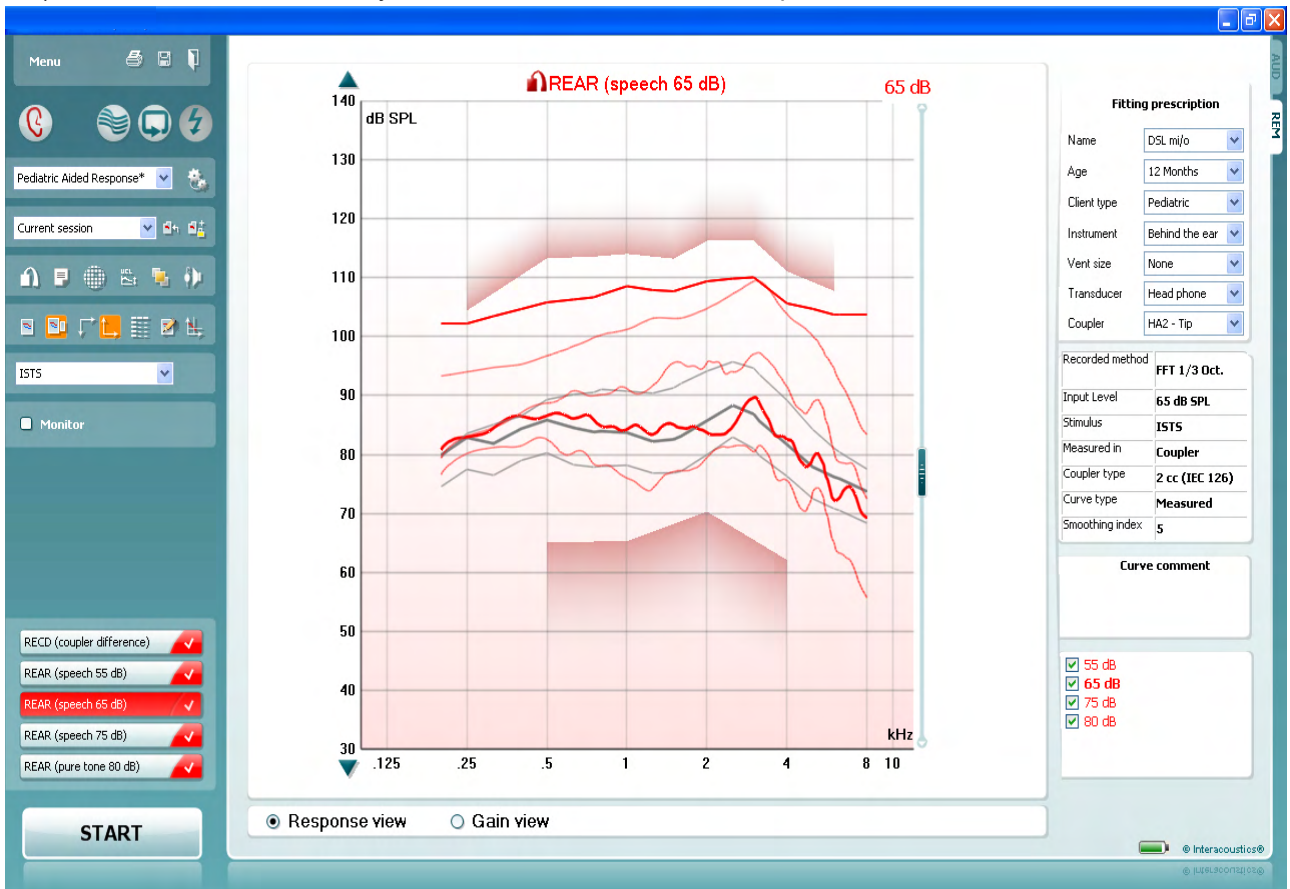

- 3) Close the lid (in the case of the TBS10).
- 4) Press **START** to conduct your measurement in the 2 cc coupler.





2.7.4.10 The “real-ear approach”

- 1) If you prefer verification in the Real-ear select *Ear mode*   
- 2) Press **START** to conduct your measurement in the real-ear as described in the previous sections.

2.7.4.11 Importing the RECD into the hearing aid manufacturers software

Some hearing aid manufacturers allow for importing the measured RECD curve into the software via Noah and/or write the measured values into a RECD screen. This way the individual ear can be considered in the fitting, and you may avoid using the average values.

For further description of how to incorporate the RECD curve into the fitting please refer to the individual hearing aid manufacturer.

2.7.4.12 Counselling the parents in visible speech mapping

Note that VSPM (Visible Speech Mapping) is available in coupler mode. Upon fitting the hearing aids, you may therefore want to enter Visible Speech Mapping for counselling purposes. This may help their understanding of both hearing impairment and hearing aids significantly (see description of Visible Speech Mapping in section 2.112).



2.7.5 REOR/REOG measurements

REOR (Real-Ear Occluded Response): The REOR accounts for the SPL across frequencies measured in the ear canal with the hearing aid in place and turned off.

REOG (Real-Ear Occluded Gain): The REOG accounts for the gain across frequencies measured in the ear canal with the hearing aid in place turned off. This is obtained by subtracting the input signal from the REOR.

$$\text{REOR} - \text{input} = \text{REOG}$$

The REOR/REOG is often used to assess the venting of a hearing aid and whether it is functioning as expected. It may also help in revealing if the vent is introducing unwanted acoustic effects.

The REOR/REOG is a good check of whether you are blocking your probe tube ahead of beginning your aided measurements.

Test procedure:



- 1) Open the REM440 module by selecting the REM tab.
- 2) If needed select a test protocol in the **List of Protocols**. If you do not select a protocol the system will automatically select a standard protocol.
- 3) Explain the procedure to the client.
- 4) Perform otoscopic examination.
- 5) Mount the probe tube on the in-situ headset and place it on the client who should be seated in ½-1 meters distance from the speaker.
Ensure that the probe tubes are calibrated before placing them in the ear canal (see section 2.6.2 about tube calibration).
- 6) Carefully insert the hearing aid without moving the probe tube. Ensure that the hearing aid is **switched off**.



7) Click on the **REOG/REOR** button if it is not already marked automatically.
A right click on the REOG/REOR button allows you to enter the *Settings* menu or *Change color* of the curve.

8) Ensure that the correct **Ear** is selected 

9) Choose the preferred **Stimulus** in the corresponding dropdown list



10) Select input level using the Input level slider

11) Click **START** and the REOG/REOR will be performed.

Note: If the curve falls below the graph area use the arrow buttons in the left side of the screen to adjust the graph as illustrated below:

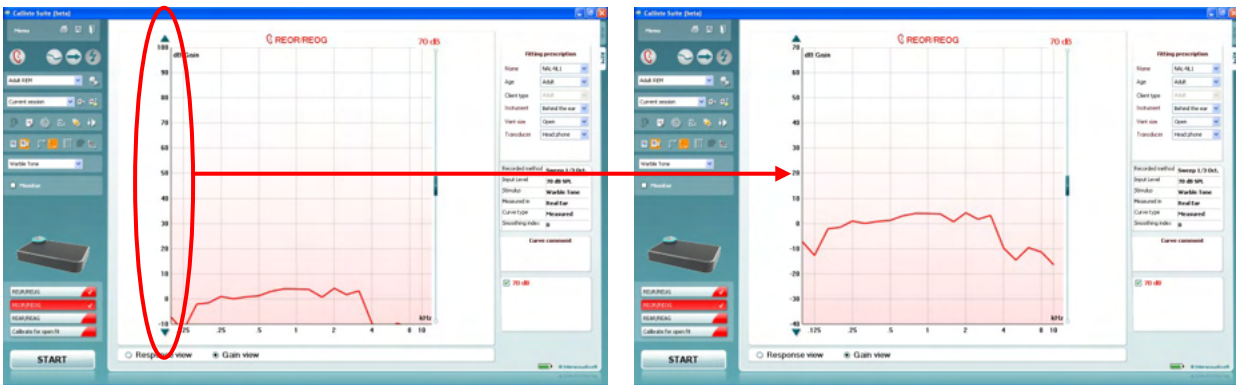



2.7.6 Measuring input/output

Input/Output: The Input/Output curve displays the output of the hearing aid as a function of the input for one frequency (or broadband signal).

The Input/Output function provides information about the compression characteristics of the hearing aid such as expansion³⁰, knee-point, and compression limiting (Dillon 2001).

Test procedure:

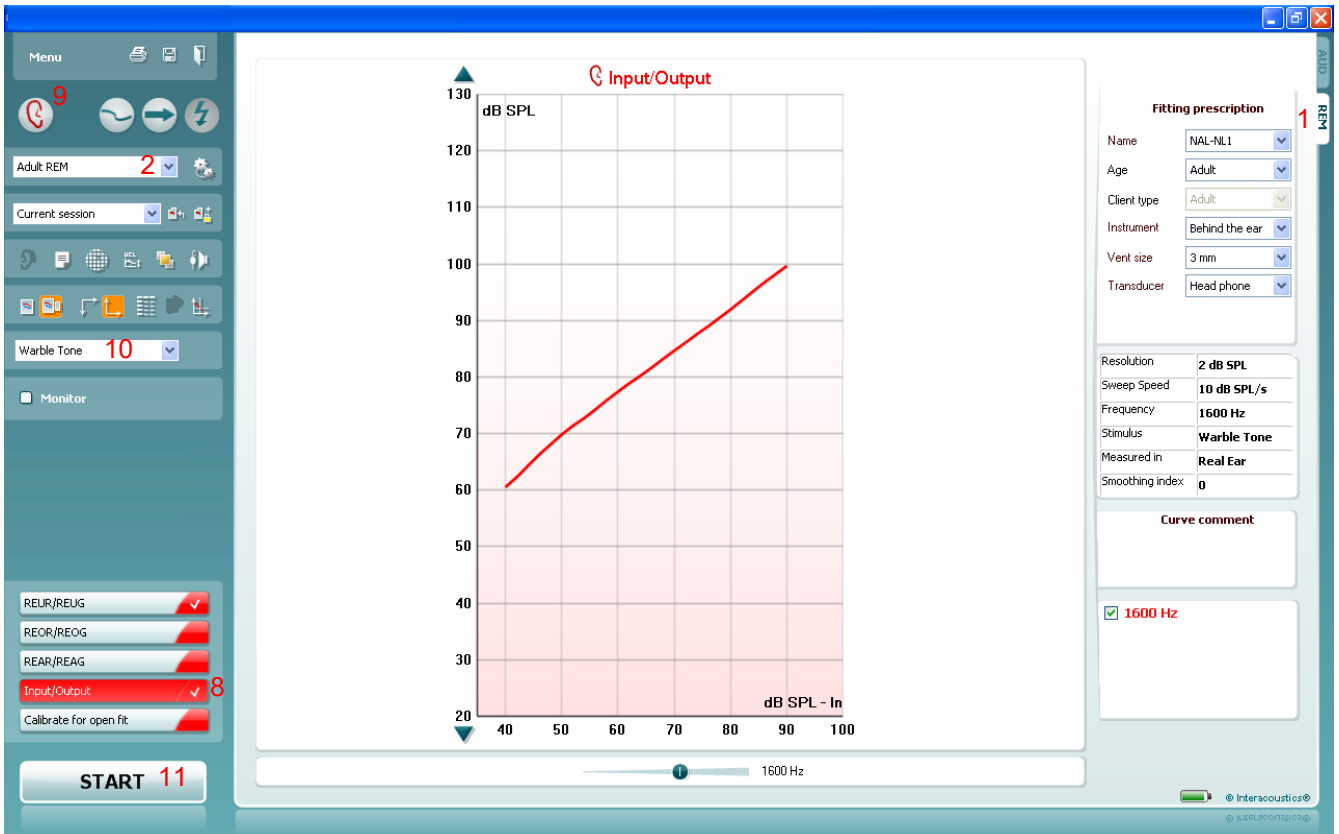

- 1) Open the REM440 module by selecting the REM tab.
- 2) If needed select a test protocol in the **List of Protocols**. If you do not select a protocol the system will automatically select a standard protocol.
- 3) Explain the procedure to the client.
- 4) Perform otoscopic examination.
- 5) Mount the probe tube on the in-situ headset and place it on the client who should be seated ½-1 meters distance from the speaker.
Ensure that the probe tubes are calibrated before placing them in the ear canal (see section 2.6.2 about tube calibration).
- 6) Carefully insert the hearing aid without moving the probe tube. Ensure that the instruments are switched on.
- 7) If fitting an open hearing aid solution, perform **Calibrate for open fit** (see section 2.6.4).
- 8) Click on the **Input/Output** button if it is not already marked automatically.
A right click on the Input/Output button allows you to enter the *Settings* menu or *Change color* of the curve.
- 9) Ensure that the correct **Ear** is selected



³⁰ Expansion is when the hearing aid gain decreases with decreases in input (Dillon 2001).



- 10) Choose the preferred **Stimulus** in the corresponding dropdown list
If you have performed Calibrate for open fit only the signals used for this calibration are available in the stimulus selection dropdown (see section 2.6.4).
- 11) Click **START** and the Input/Output measure will be performed.

2.7.7 Directionality measurements

Unwanted noise will inevitably turn up in daily life situations. Fortunately, many digital hearing aids have directional microphones that suppress noise coming from some directions while maintaining a good sensitivity to sounds coming from another direction. This effect can be measured in the real-ear. Place the client in front the REM loudspeaker. First a response curve/frequency response is recorded for sounds coming from the front. After this turn the client around facing the opposite direction and a similar curve will be recorded for sounds coming from the back. Then the second curve is subtracted from the first and results in the directionality curve.

If preferred the directionality test can also be performed using a free field speaker as the back speaker.

Test procedure:



- 1) Open the REM440 module by selecting the REM tab.
- 2) Select a test in the **List of Protocols**. If a customized test setup is not created the REM440 will automatically pick a standard test.
- 3) Explain the procedure to the client.
- 4) Perform otoscopic examination.
- 5) Mount the probe tube on the in-situ headset and place it on the client who should be seated in ½-1 meters distance from the speaker.
Ensure that the probe tubes are calibrated before placing them in the ear canal (see section 2.6.2 about tube calibration).
- 6) Carefully insert the hearing aid without moving the probe tube. Ensure that the instruments are switched on.



- 7) If fitting an open hearing aid solution, perform **Calibrate for open fit**
Click on the **Directionality** button if it is not already marked automatically.
A right click on Directionality button allows you to enter the *Settings* menu or *Change color* of the curve.
- 8) Check that the information about client, fitting prescription and hearing aid to the right are correct.

- 9) Ensure that the correct **Ear** is selected



- 10) Choose the preferred **Stimulus** in the corresponding dropdown list .
If you have calibrated for open fit only the signals used for this calibration are available in the stimulus selection dropdown (see section 2.6.4).



- 11) Select input level using the Input level slider
- 12) Click **START** and follow the instructions on screen.
- 13) Place the client in front of the loudspeaker as shown on the picture. Click **OK** and front microphone curve will be recorded. New instructions will immediately appear.

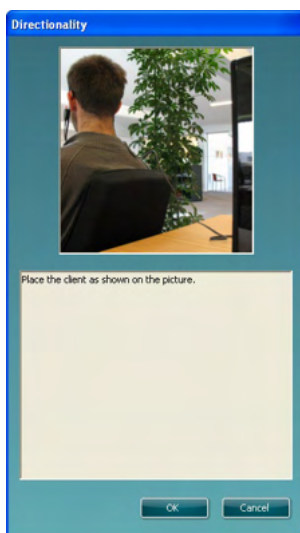
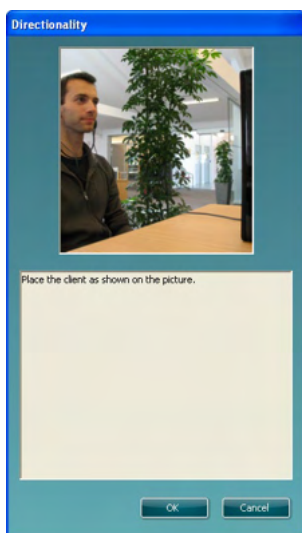

- 14) Turn the client around and click **OK**. The directionality curve will then be finalised as shown above³¹.

Note: The continuous measurement button is disabled for Directionality. Measurement time must therefore be set in the REM440 setup (see section 2.8.2.7).

2.7.8 Binaural REM measurements

This is a feature which allows binaural measurement of real ear measurements simultaneously. This makes it easier and quicker to perform this measurement.

This test involves the placement of the probe tube microphone in each of the patient's ears at the same time and referencing is performed with only one of the reference microphones. Therefore, this test requires that the patient is orientated at 0° from the speaker to ensure that there is equal distance to the speaker from each ear.



Binaural REM can only be used with stimuli which do not require active referencing during the measurement. Therefore, Binaural REM is not suitable for measurement with Warble Tone, Pink Noise, Random Noise, Pure tone, and Narrowband Noise.

No specific protocol is required to perform Binaural REM as it uses the settings from your existing protocols. However, a protocol can be defaulted to start up in Binaural REM measuring mode by enabling the below setting in the REM protocol.

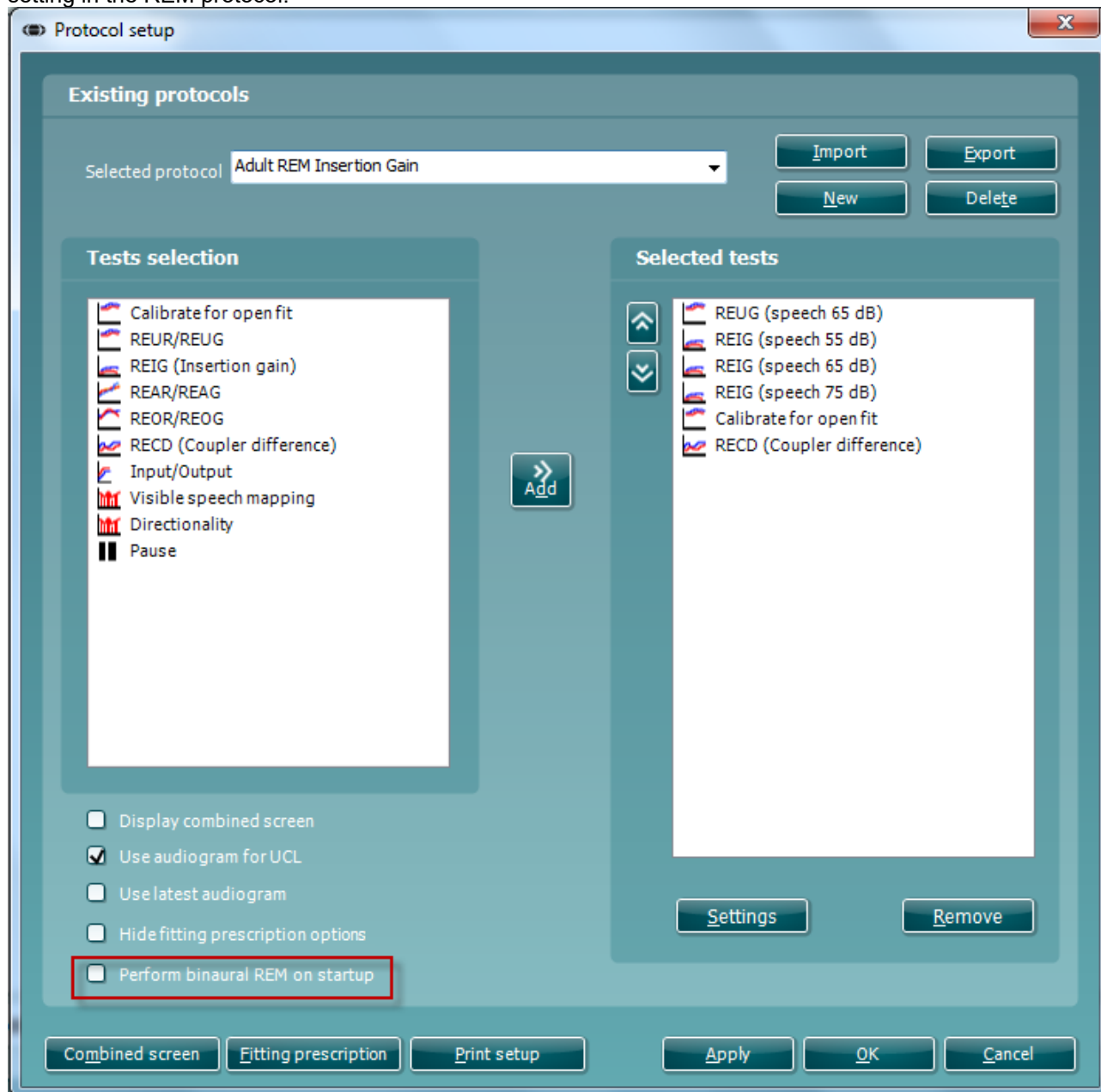

Required items:

- The Callisto™ hardware
- Licensed Callisto™ hardware with REM440 REM module
- Calibrated REM headset
- REM protocol



Procedure

1. Enter/Select an audiogram from Noah or from the AUD module. **If no audiogram is entered or selected, no targets will be displayed.**
2. To enable Binaural REM measurements in the REM module you will need to Right click on the ear selector icon. This will then show a binaural icon and a popup to alert the user when using this function.



Due to the way in which this feature has been implemented you will not need to recreate new protocols to use this function. It uses the settings you already have in your existing protocols.

Please note when running measurements of this type you will only be using one reference microphone to monitor the signal from the speaker. This is the right microphone by default, but it can be swapped to the left microphone by using the 'use opposite ref. mic. Button'.

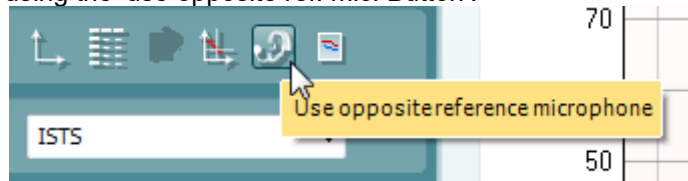

It is also essential that the position of the patient in relation to the REM speaker is maintained at 0° as this will ensure that the same signal intensity is reaching each ear as they are equal distance from the speaker.

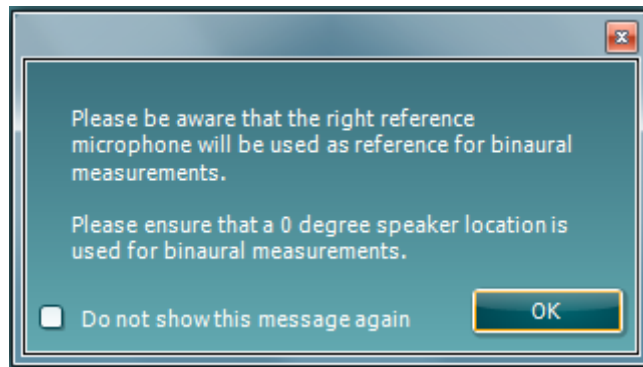

3. Connect **probe tubes** to the REM reference microphones.



4. Click on the **Tube Calibration** button and follow the instructions on the screen, this process ensures that the probe tube is made acoustically invisible – enabling an effective display of the actual gain achieved at the tympanic membrane by the hearing aid.
On running the calibration, you will notice that in Binaural mode there is an automated procedure to calibrate both Left and Right REM tubes sequentially, without having to manually start each individually.
5. Position the patient approximately **0.5 metres** from the REM loudspeaker.
6. Perform **otoscopy** to ensure the ear canal is clear.
7. Snap the REM headsets on the REM headband and place on patient's ear.
8. Choose a relevant protocol to perform your verification, in this example the default 'Adult Insertion Gain' protocol has been used.

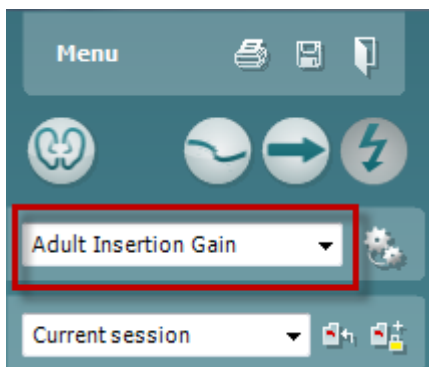

Note: For this example, an Insertion Gain method has been used to demonstrate the Binaural REM feature, however the feature is also compatible with protocols which perform this measurement in an Aided Response method.

9. Once you have chosen your protocol, please configure your fitting prescription settings as per your fitting.

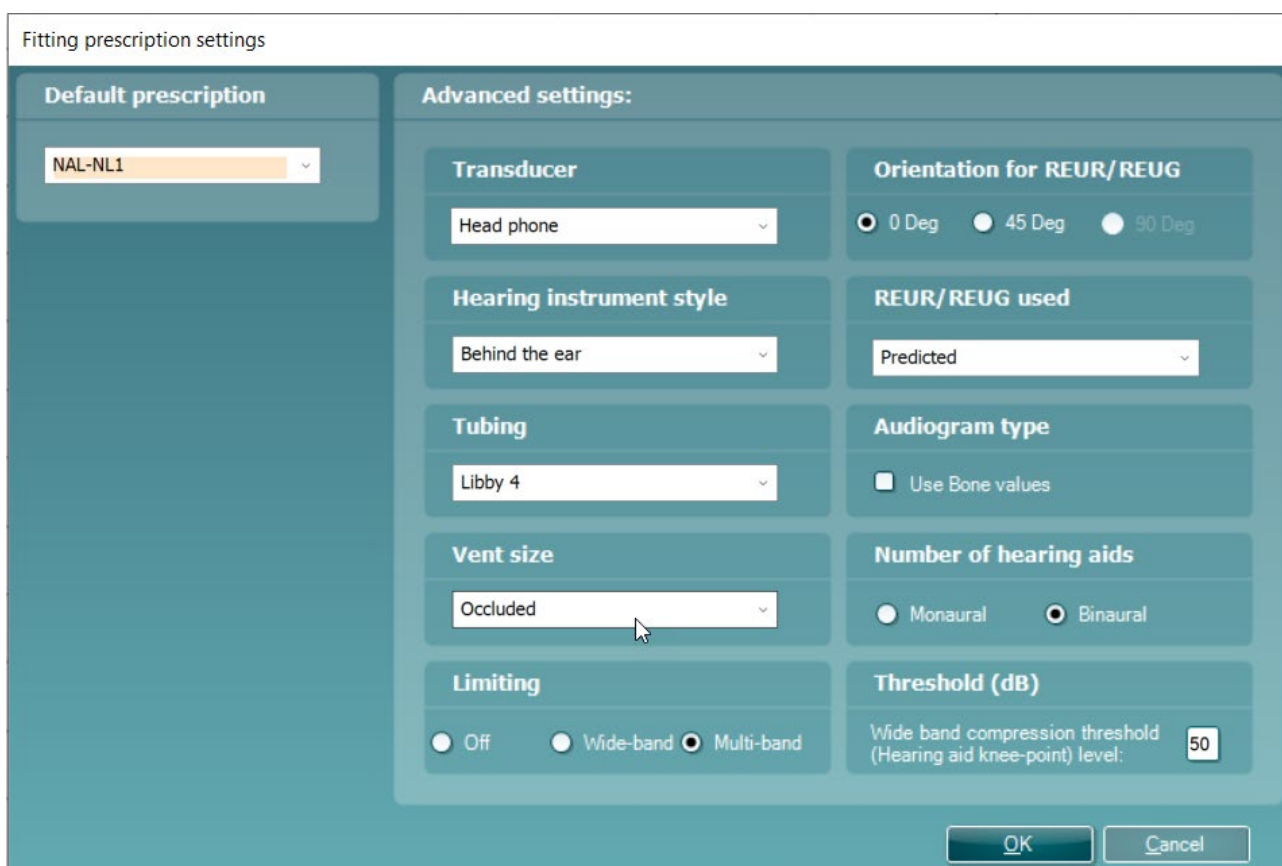

10. Place the REM tubes inside the patient's ears and aim to use a marker of roughly 27mm on the probe tubes. This helps to get the open end of the tube in an optimum recording position (BSA, 2007).
11. Begin by running the REUR measurement, this is looking at the natural acoustics of your patients' ear canals, it is performed with nothing in the patients ear canals apart from the probe tubes. Your response should peak around 2-3kHz for a normal adult response (BSA, 2007). The shape of this measurement can also be used as a quality criterion for your probe placement, the measurement should intersect the



Horizontal axis (x-axis) at 6kHz and must not be more negative than -5dB (BSA, 2007 & ISO, 2003).

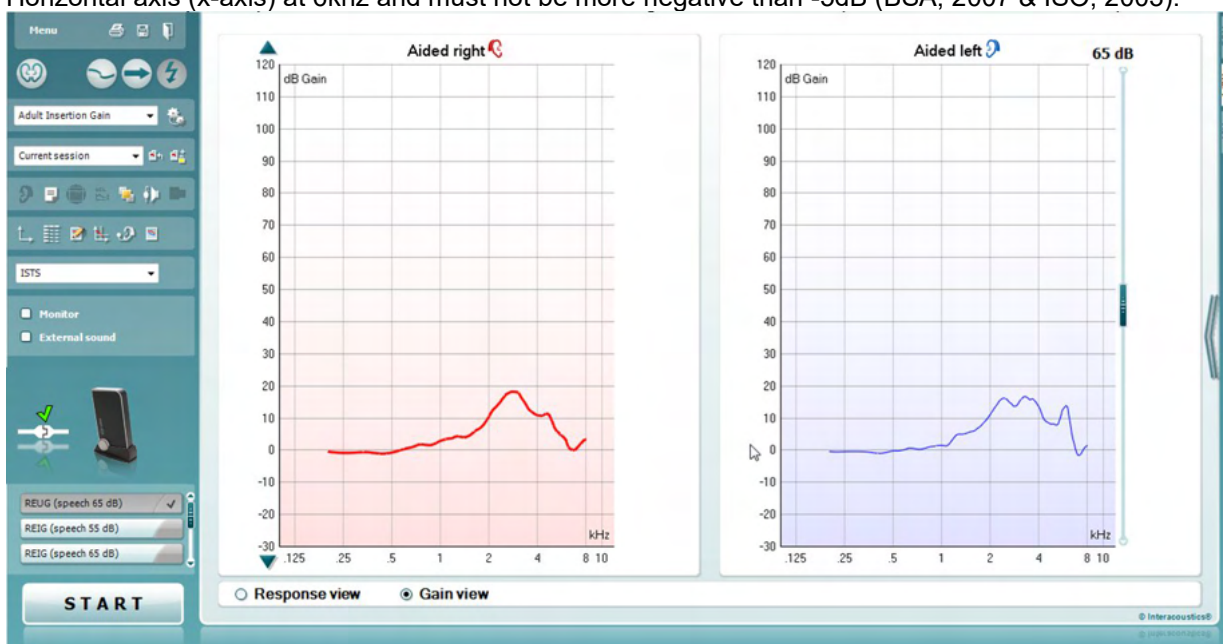

12. You can now proceed to running the REIG measurements, there are 3 different intensity measurements in this protocol, but the focus should be to fit the 65dB curve as this is the intensity for speech.

Please place the hearing devices into your patient's ears along with the probe tubes for the following measurements.

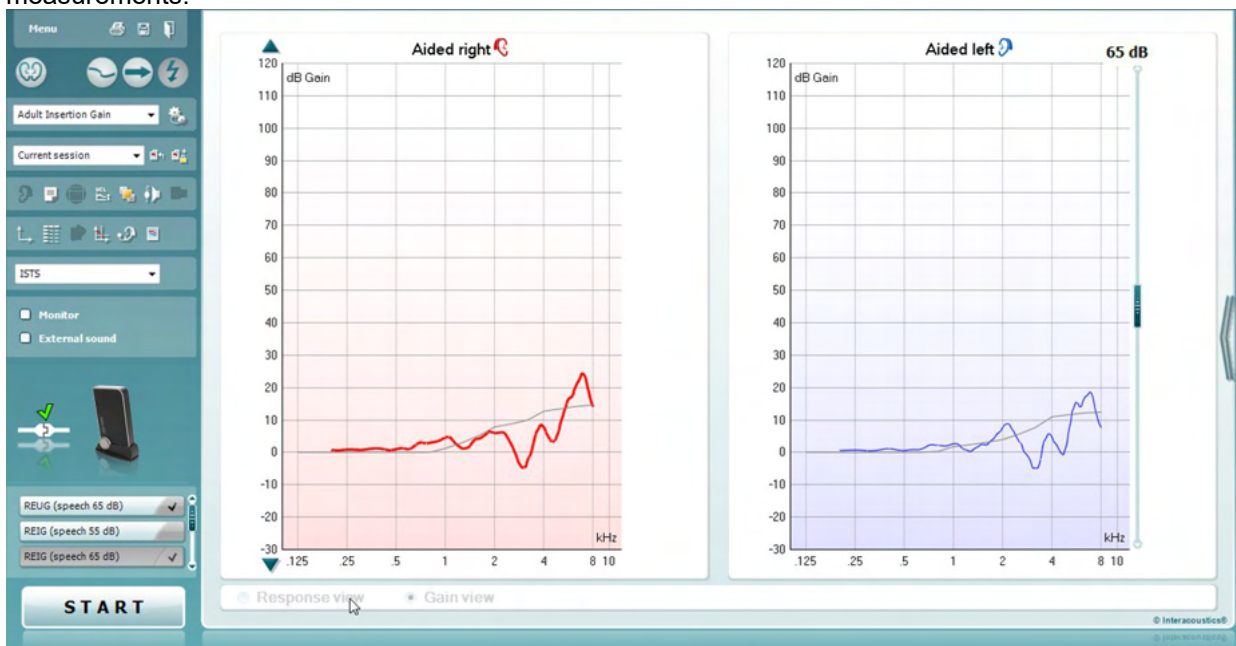

You will notice that there is a target in these measurements; in the next step it is shown how you can amend the output of the patient's hearing devices to meet these targets.

Note: the default view for the Binaural REM feature is to have the left and right aided measure displayed side-by-side. However, this can be swapped to an on-top comparison by pressing the button shown below, there is an example of this view below.

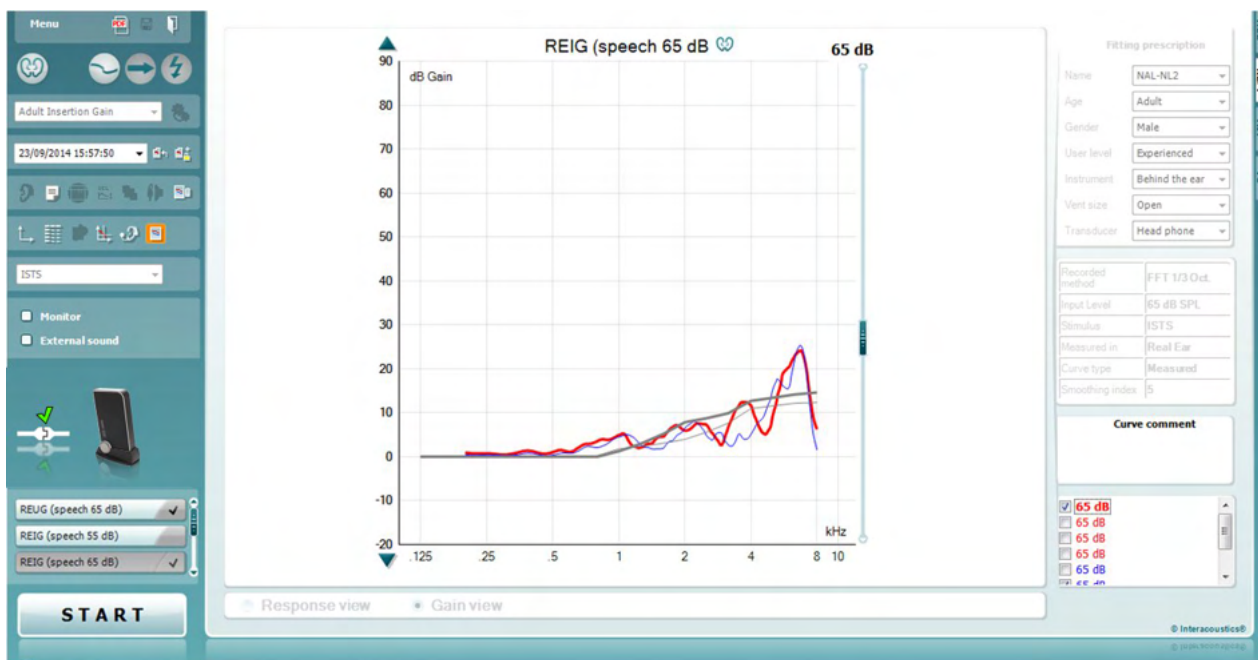

13. You will now begin fine tuning in the hearing aid fitting software to amend the output of the device to meet the prescription target.

14. Should you wish to edit the targets when performing a binaural measurement then you should click on



this icon. Doing this will open the below dialogue screen which will allow you to edit the target for each independent ear currently on the screen or input your own, i.e. a proprietary target from a hearing aid fitting software.

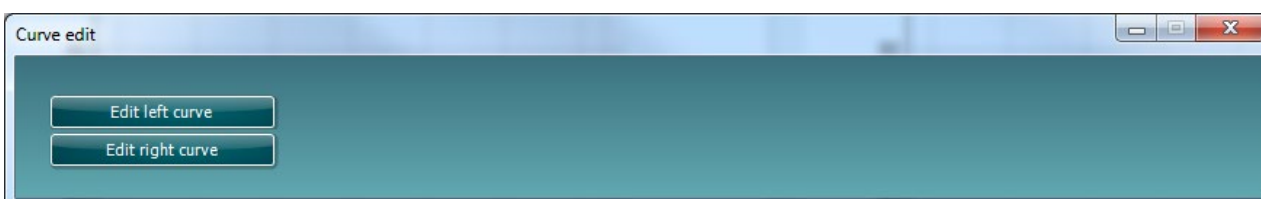

Frequency (Hz)	125	250	500	750	1000	1500	2000	3000	4000	6000	8000	10000
Intensity (dB)		40	46	46	47	50	55	55	52	49	46	

On setting a custom target it reverts the target to a 'Custom target' from a previously set standard target (NAL, DSL etc.) on doing this you should input values for both ears otherwise no target will appear. Note: Using this feature will remove your previous target allocation (i.e., NAL-NL2, DSLmi/o etc) from the opposite ear side, which you have not provided custom values for, because we cannot allow different prescription methods to be used on different ears independently.



15. A nice feature in the Callisto™ and Callisto™ Suites is the On top mode. This feature allows you to minimize the suite so that it can be placed on top of the fitting software to make it easier to fine tune and compare the output following your changes. This feature can be used on pressing the following button on

the left of the Suite GUI

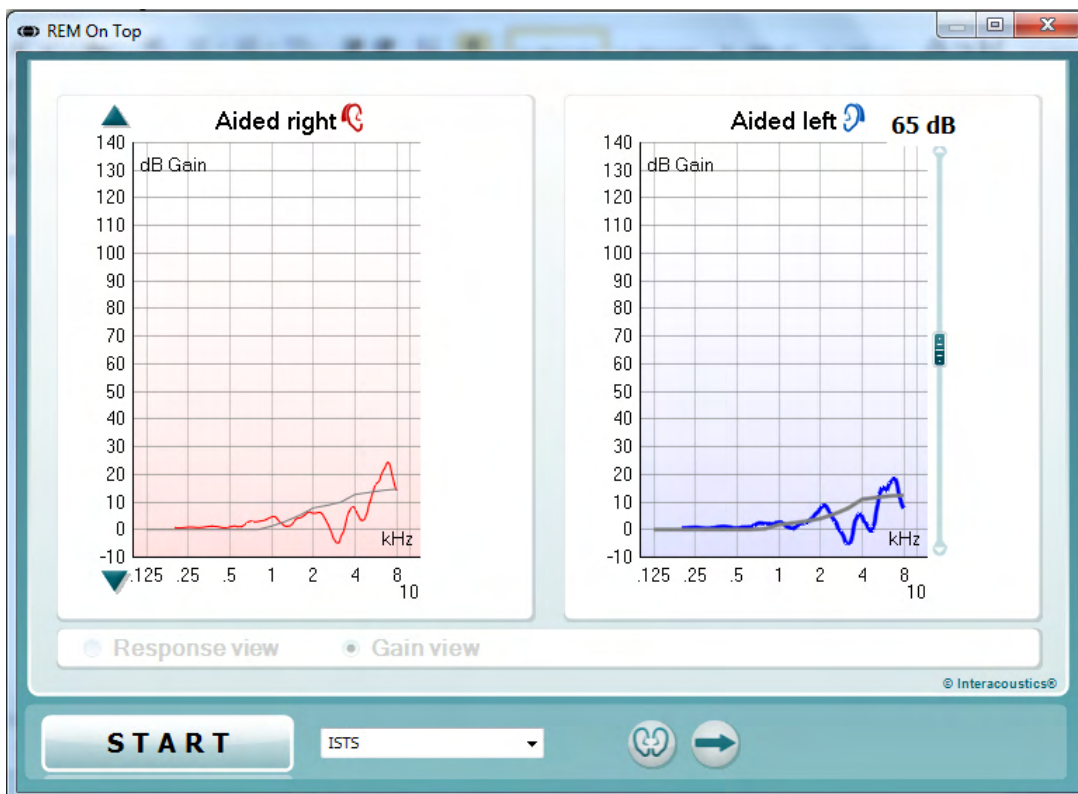
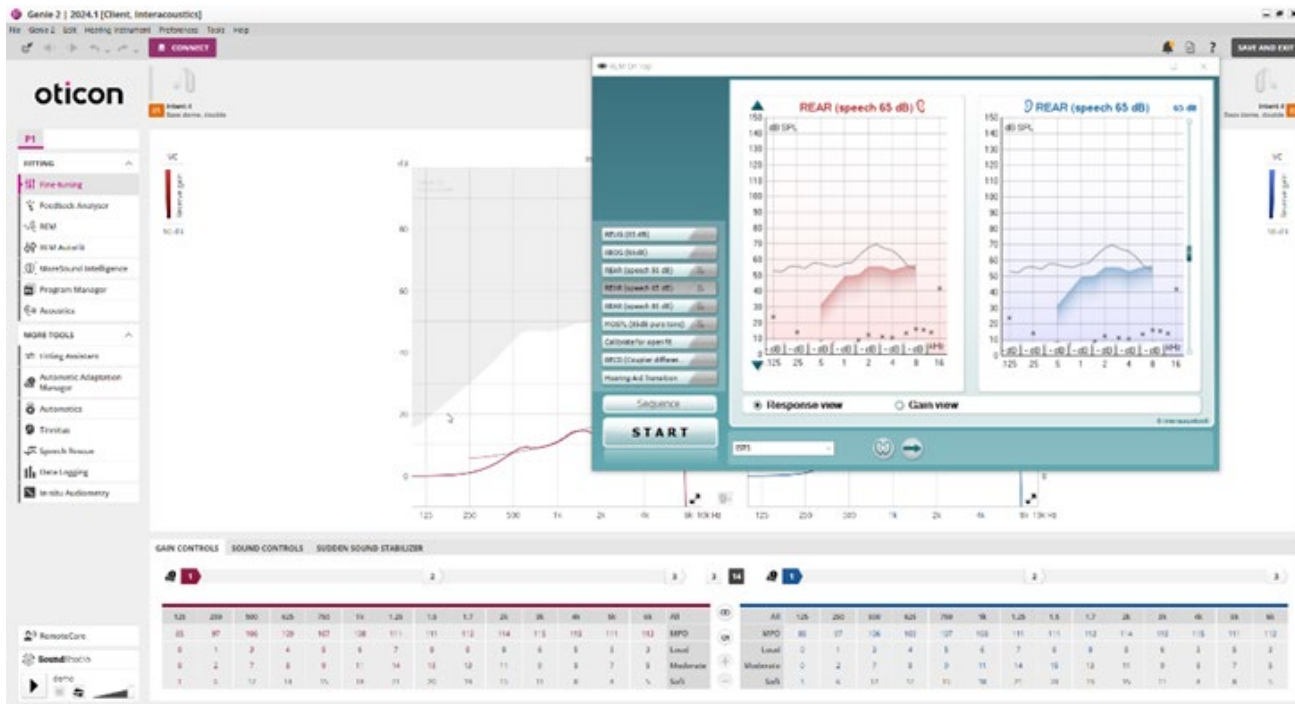



16. Once you have fine-tuned your hearing devices so that the patient is happy and have counselled them involving their opinions in the amplification of their hearing devices you can save and close the Suite and finish the session. This is done by pressing the 'Save and Exit' button 

Note: Binaural REM can also be used when fitting Open Fit type hearing aids. All this requires is for the 'Open Fit Calibration' to be run following the REUR measurement for the signal(s) you wish to use for the following measurements.



2.8 Working with individual setups (test protocols)

The REM440 module is pre-programmed with standard protocols ready for use which can be selected from the front screen. However, you may wish to create an individual test protocol accommodating for personal preferences and test methods.

This section describes both how to select a pre-programmed protocol and how to create an individual test protocol.

2.8.1 Selecting a test protocol

- 1) Open the REM440 module by selecting the REM tab in the Callisto™ Suite.
- 2) In the **List of Protocols** all standard and individual test protocols are listed.

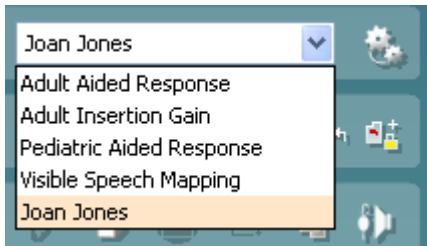

- 3) When selecting a protocol, the tests of the specific protocol will then be listed in the lower left corner ready for use.





2.8.2 Creating new test protocols

The following sections describe how to setup your own protocol in the REM440 setup. All setup options for all tests will be described even though you most likely will only need a few. This section is therefore to be seen as a work of reference where single functions can be looked up rather than a step-by-step guide where all steps need to be explored.

- 1) Enter the REM440 setup by pressing **Menu/Setup/REM440 setup**
- 2) Press **New**

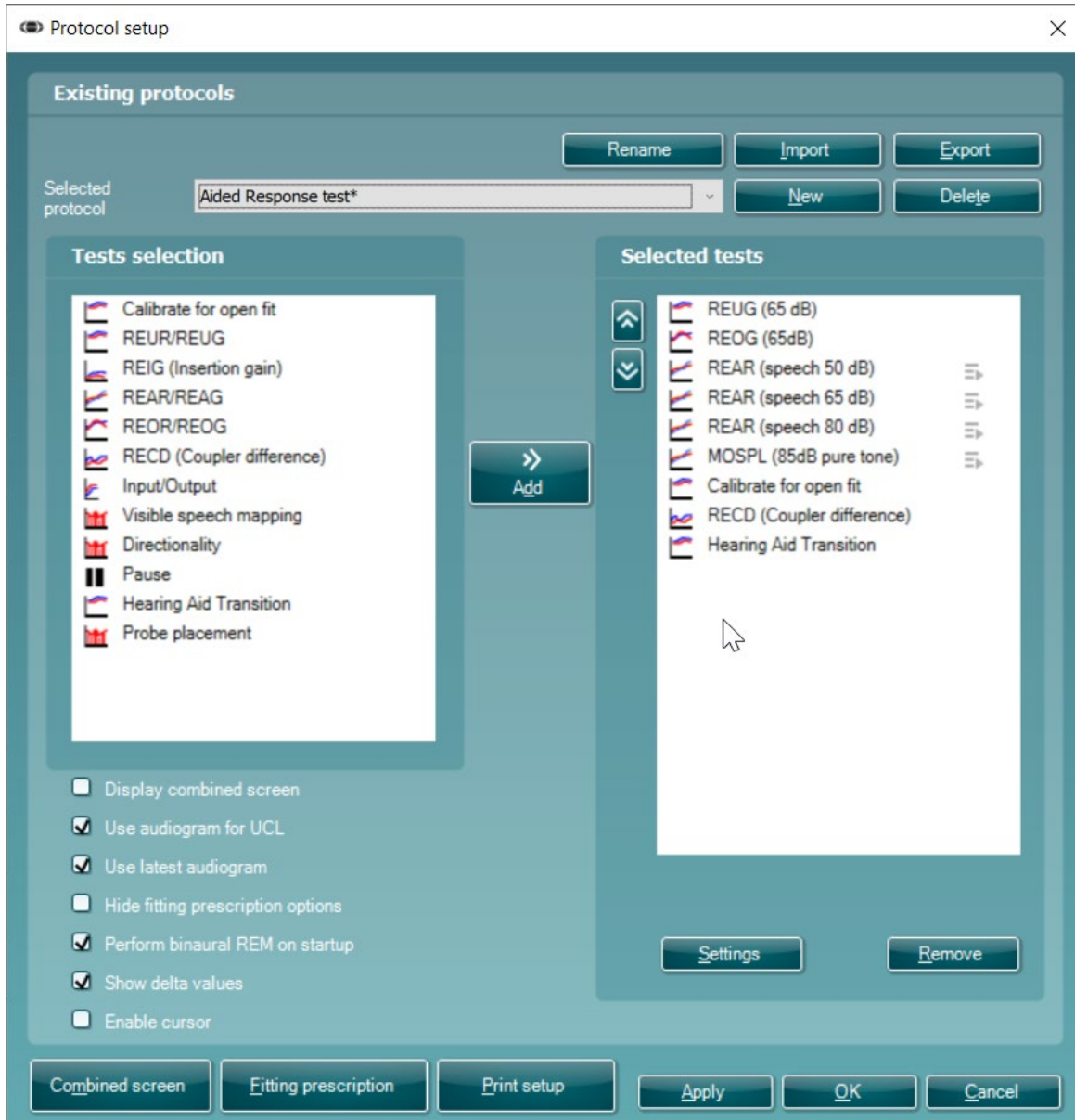



- 3) A pop-up will ask whether the new protocol should be based on a copy of the currently selected protocol. When asked by the message box:

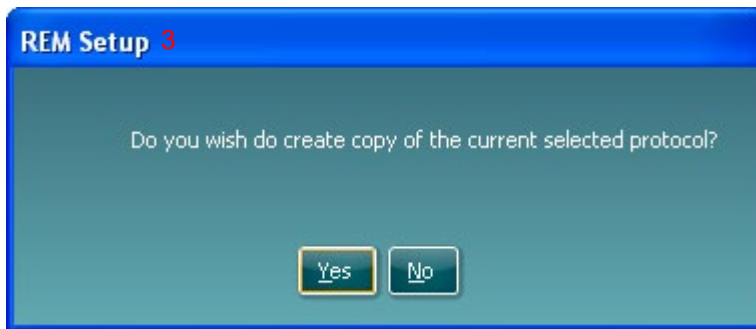



Yes: The system will create a copy of the current test and allow you to add new tests, make changes, and save it under a new name.

No: The *Selected tests* section will be blank, and you can create a new test from scratch.

4) Name the protocol setup in the **Selected protocol** section.

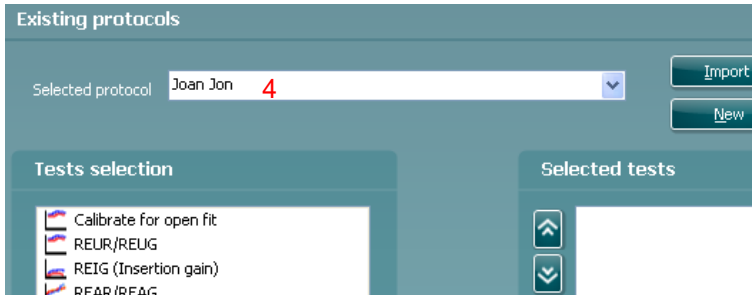

5) Select the tests to be included in the test protocol.
Mark a test by clicking on it and press the **Add**. Double clicking on a test will also select it.
Choose all the tests for the protocol using this procedure.

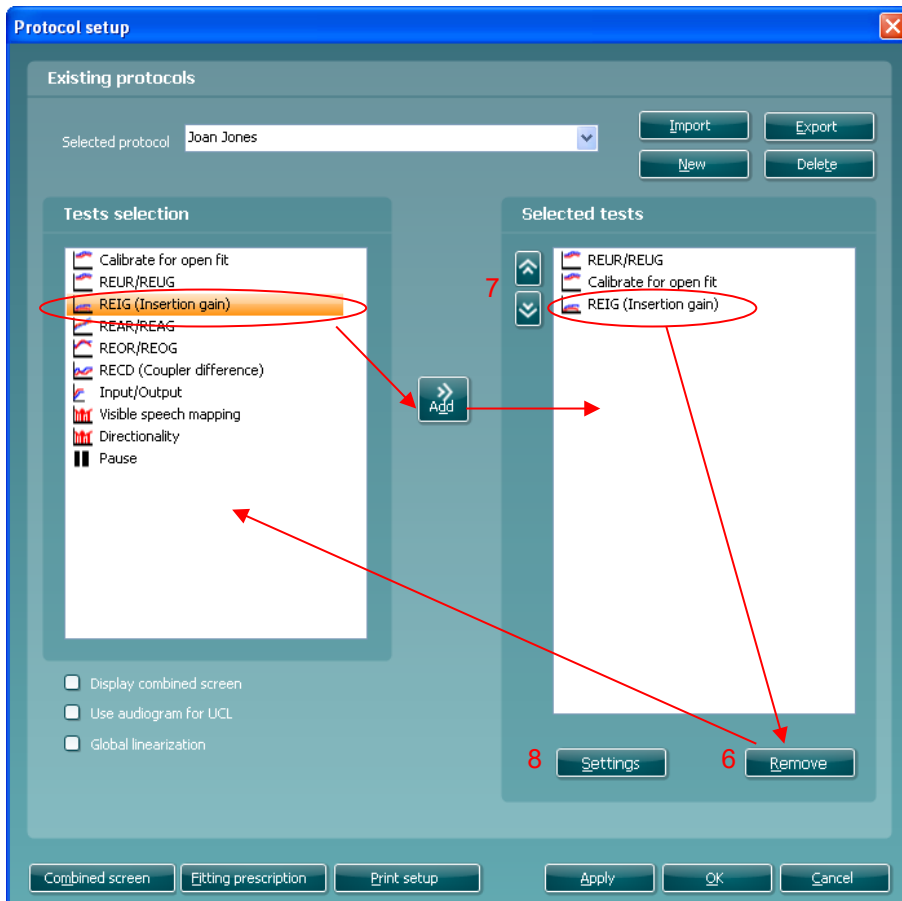

To remove a test selected by mistake, mark it under *Selected tests* and press **Remove**. The test will then jump back to the *Test selection* list.



- 6) If the order of the tests is to be changed, use the *two Move arrow* buttons. **Mark** the test to be moved and press one of *the arrow buttons*. Depending on the direction of the selected arrow, the test will then jump up or down.
- 7) To adjust the parameters of each selected test press **Settings**.

Below the selection list seven check boxes are found:

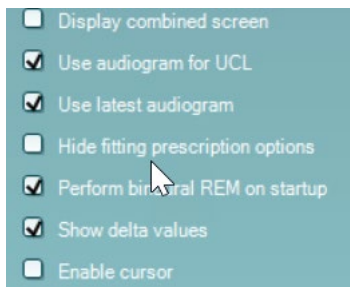

Display combined screen allows for comparing different curves in the same display. Which curves to compare can be setup individually (see section 2.6.13.3).

Use audiogram for UCL provides you with the option to adjust UCLs transferred from the audiogram screen. When using the NAL-NL1, NAL-NL2 or DSL *m[i/o]* fitting prescriptions UCLs from the audiogram screen will automatically be transferred to the REM440 screen where they are indicated in shading.

Use latest audiogram means that the latest audiogram will always be used to calculate the target in the REM screen

Hide fitting prescription options will hide the fitting prescription options panel on the right-hand panel of the REM screen:

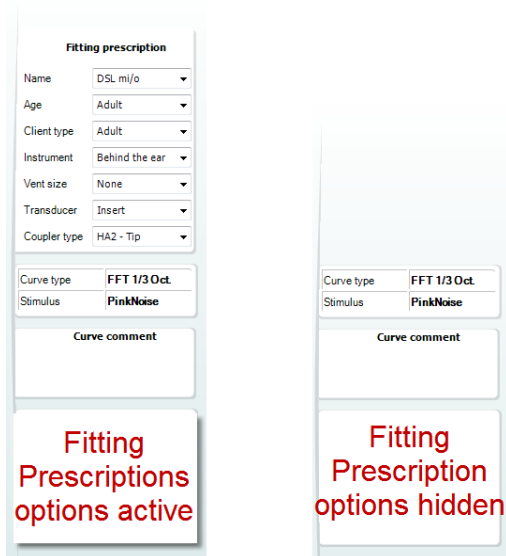

Perform Binaural REM on Start-up allows you to enable default Binaural REM recording on launching the software for this selected protocol.

Show Delta Values enables the Delta values feature as defaulted on for this protocol.

Enable cursor enables the cursor to act as a cross hair function on the graph



2.8.2.1 REUG/REUR settings

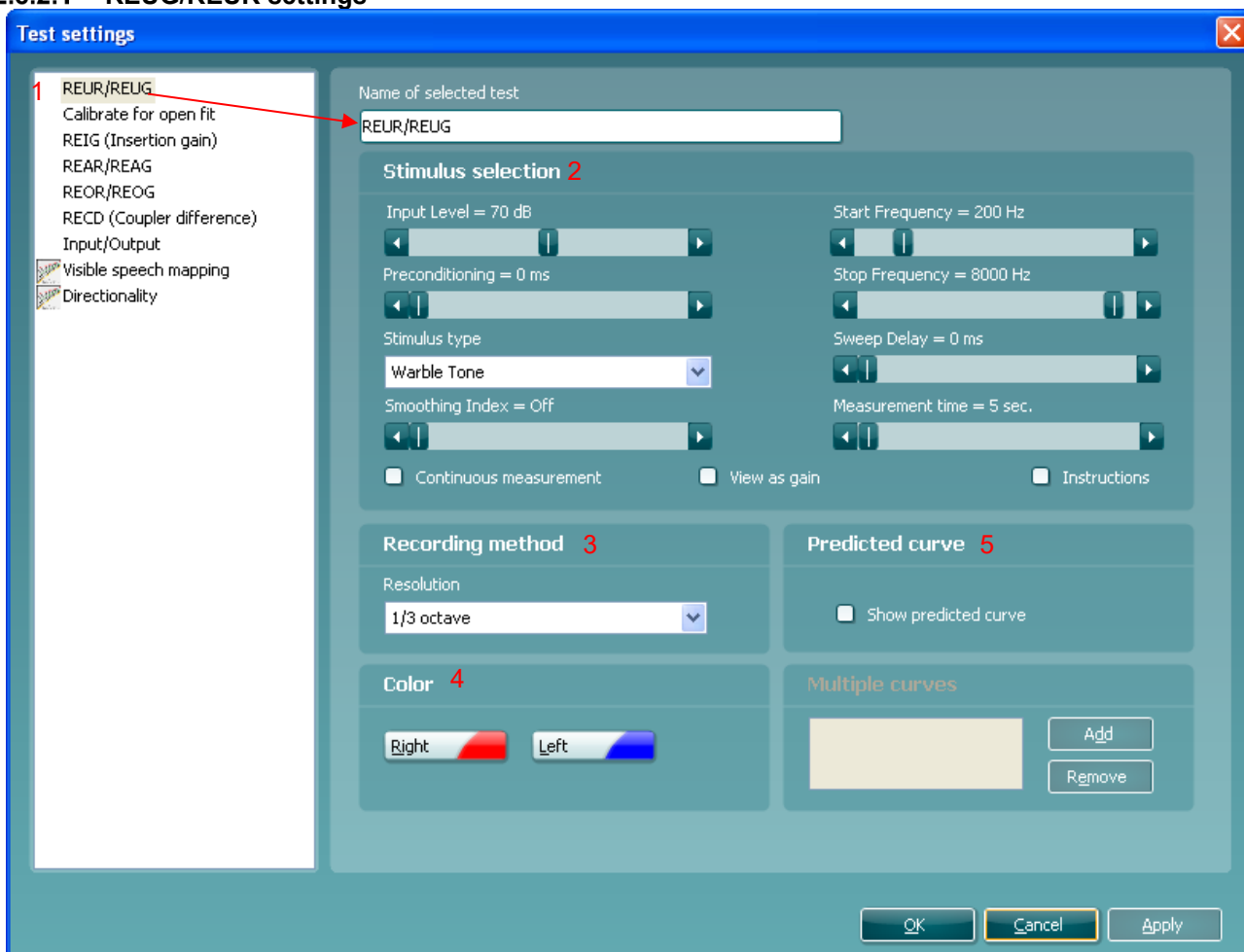

1) Ensure that **REUR/REUG** is marked in the left-hand side of the screen. The name of the test will then appear in the *Name of selected test* section. Note the option to write a new name for the test in this section (e.g., “REUR/REUG 70 dB input”)

2) **Stimulus selection:**

- *Input Level:* Set the input level using the slider.
- When using broadband signals such as ICRA (see section 2.6.10.1 for details). Select a time using the slider.
- *Stimulus type:* Select a stimulus using the dropdown list.
- *Smoothing Index:* You have the option to smooth the measured curve using the slider (see section 2.6.11 for details). The higher index number selected the more smoothing is applied.
- *Continuous:* This check box allows you to make the measurement on going rather than a single sweep. This may, however, also be done in the front screen using the continuous button:



When continuous is ticked, the stimulus and recording will continue until you press the STOP button.

- *View as gain:* allows you to view the measurement as a gain curve by default. If you wish to view it as response, ensure that the check box remains unticked (see section 2.6.3 for details regarding Gain versus Response view).
- *Start Frequency and Stop Frequency:* Select the preferred frequencies using the sliders. To avoid low frequency noise set the slider to a start frequency of 200Hz.



- **Sweep delays:** This is relevant if *Continuous measurement* is selected for Pure Tone or Warble Tone. In this case sweep delays (in milliseconds) may be entered between the individual sweeps (see section 2.6.10.2 for details).
 - **Measurement time** (in seconds): Duration for the measurement can be set using the slider. This is only relevant for broad band signals. Several seconds can freely be selected between 1 and 1200. By default, the measurement time is the same for all signals.
 - **Instructions:** This allows for adding picture instructions. If the box is ticked an instruction box explaining how to perform the measurement will appear each time upon pressing START.
- 3) **Recording method:**
- **Resolution** (of frequency): Select the preferred resolution in the dropdown. The higher the resolution the slower the measurement. Keep in mind that 1/3 is what is used in many hearing aid manufacturers software. If the curve is to be compared to this, you may consider choosing this resolution. Also note that when using a broad band signal the dropdown list will be greyed out and automatically choose FFT. This makes the distance between frequency bins 43 Hz which ensures precision in the measurement.
- 4) **Color:**
- Select a color for the *Right* and *Left* curve. Press each of the buttons to have the custom color selection below. Choose the desired color by clicking on it and press **OK**.

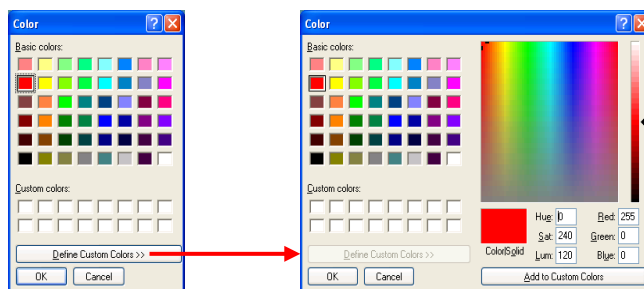

Note the option to *Define Custom Colors* to get a more extensive selection. When having found the exact color, press *Add to Custom Colors*.

- 5) **Predicted curve**
- **Show predicted curve:** If you wish not to measure the REUR/REUG you can select to use a predicted REUR/REUG as default by ticking the check box.



2.8.2.2 REAR/REAG settings

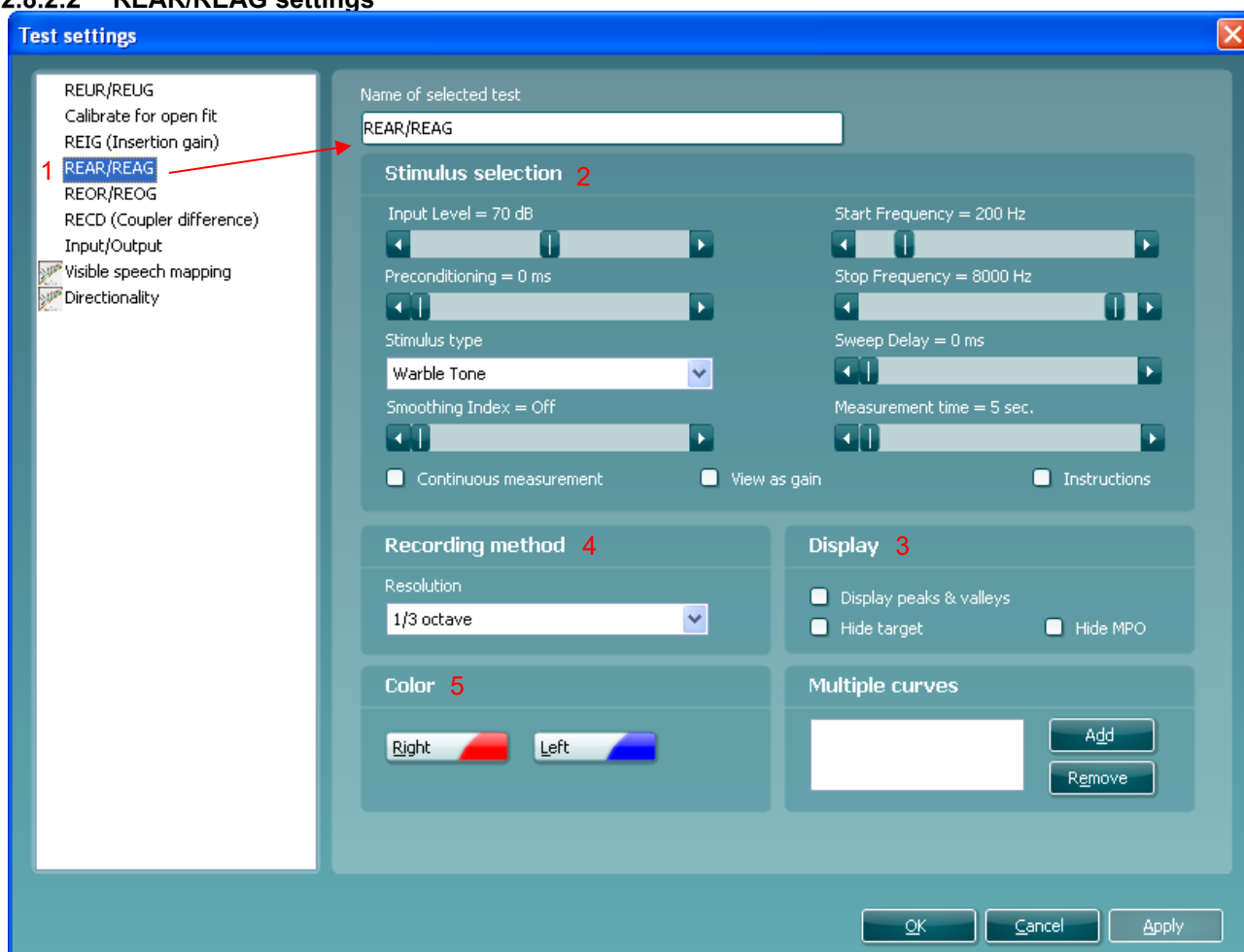

- 1) Ensure that **REAR/REAG** is marked in the left-hand side of the screen. The name of the test will then appear in the *Name of selected test* section
Note the option to write a new name for the test in this section (e.g., “REAR/REAG 70 dB input”)
- 2) **Stimulus selection**
 - *Input Level*: Set the input level using the slider.
 - *Preconditioning*: This is relevant when using broadband signals such as ICRA (see section 2.6.10.1 for details). Select a time using the slider.
 - *Stimulus type*: Select a stimulus using the dropdown list.
 - *Smoothing Index*: You have the option to smooth the measured curve using the slider (see section 2.6.11 for details). The higher index number selected the more smoothing is applied.
 - *Continuous*: This check box allows you to make the measurement on going rather than a single sweep. This may, however, also be done in the front screen using the continuous button:



When continuous is ticked, the stimulus and recording will continue until you press the STOP button. This can be practical either if you want to change the settings of the hearing aid and observe the changes in hearing aid performance.

- *View as gain* allows you to view the measurement as a gain curve by default. If you wish to view it as response, ensure that the check box remains unticked (see section 2.6.3 for details regarding Gain versus Response view).



- **Start Frequency and Stop Frequency:** Select the preferred frequencies using the sliders. These may for example be set so that they correspond with the hearing aid gain handles (e.g., if the hearing aid goes up to 8000 Hz there is no reason to measure beyond this frequency). To avoid low frequency noise, you may wish to set the slider to a start frequency of 200Hz.
- **Sweep delays:** This is relevant if *Continuous measurement* is selected for Pure Tone or Warble Tone. In this case sweep delays (in milliseconds) may be entered between the individual sweeps (see section 2.6.10.2 for details).
- **Measurement time** (in seconds): Duration for the measurement can be set using the slider. This is only relevant for broad band signals. Several seconds can freely be selected between 1 and 1200. By default, the measurement time is the same for all signals.
- **Instructions:** This allows for adding picture instructions. If the box is ticked an instruction box explaining how to perform the measurement will appear each time upon pressing START.

3) Recording method:

Resolution (of frequency): Select the preferred resolution in the dropdown. The higher the resolution the slower the measurement.

Keep in mind that 1/3 is what is used in many hearing aid manufacturers software. If the curve is to be compared to this, you may consider choosing this resolution. Also note that when using a broad band signal the dropdown list will change to offer weighting instead.

4) Color:

- Select a color for the *Right* and *Left* curve (see section 2.8.2.1 regarding REUR/REUG for details).

5) Multiple curves:

- The Multiple curves option, if configured, will run a series of concurrent differing intensity levels when you press start in the test screen. Set the first level using the Input Level slider and press *Add* under Multiple Curves. The level will then appear in the corresponding white section as the Primary intensity. Select the second level and press *Add* again. The new level will then be listed under the first one. If a level is selected by mistake click on it in the white section and press *Remove*.

6) Display:

- **Display Peaks and Valleys:** This is relevant when using a broad band signal. When ticking the check box, the REM440 will show the measured maximum and minimum in speech spectrum over time (5 seconds) on screen. The measurement is independent of the selected measurement time.
- **Hide target:** This will remove the fitting target from the screen by default
- **Hide MPO:** This will remove the MPO when using the DSL mi/o fitting prescription in Response view.
- **1/3 octave and overlapping time window:** For speech-like signals, the signal is converted into an FFT and then sampled. The clock frequency of the Callisto™ is 44100 Hz and we do 1024 samples per second. This means that the time for each sample is 23 ms.
- **Percentiles for full measurement:** activate this box if you want to see the intensity components in different shaded percentile sections – these are customisable and will show the output as a shaded range on the graph.
- **Show dynamic compression ratio:** Enabling this feature will display the dynamic compression ratios when the 1/3 octave and overlapping time windows option is enabled. *Set settings to IEC 60118-15:* use this button to set the measurement settings according to the IEC 60118-15 standard³² this will amend the settings mentioned above to meet this configuration description.

³² For detailed information, please refer to the IEC 60118-15 standard.



2.8.2.3 REIG settings

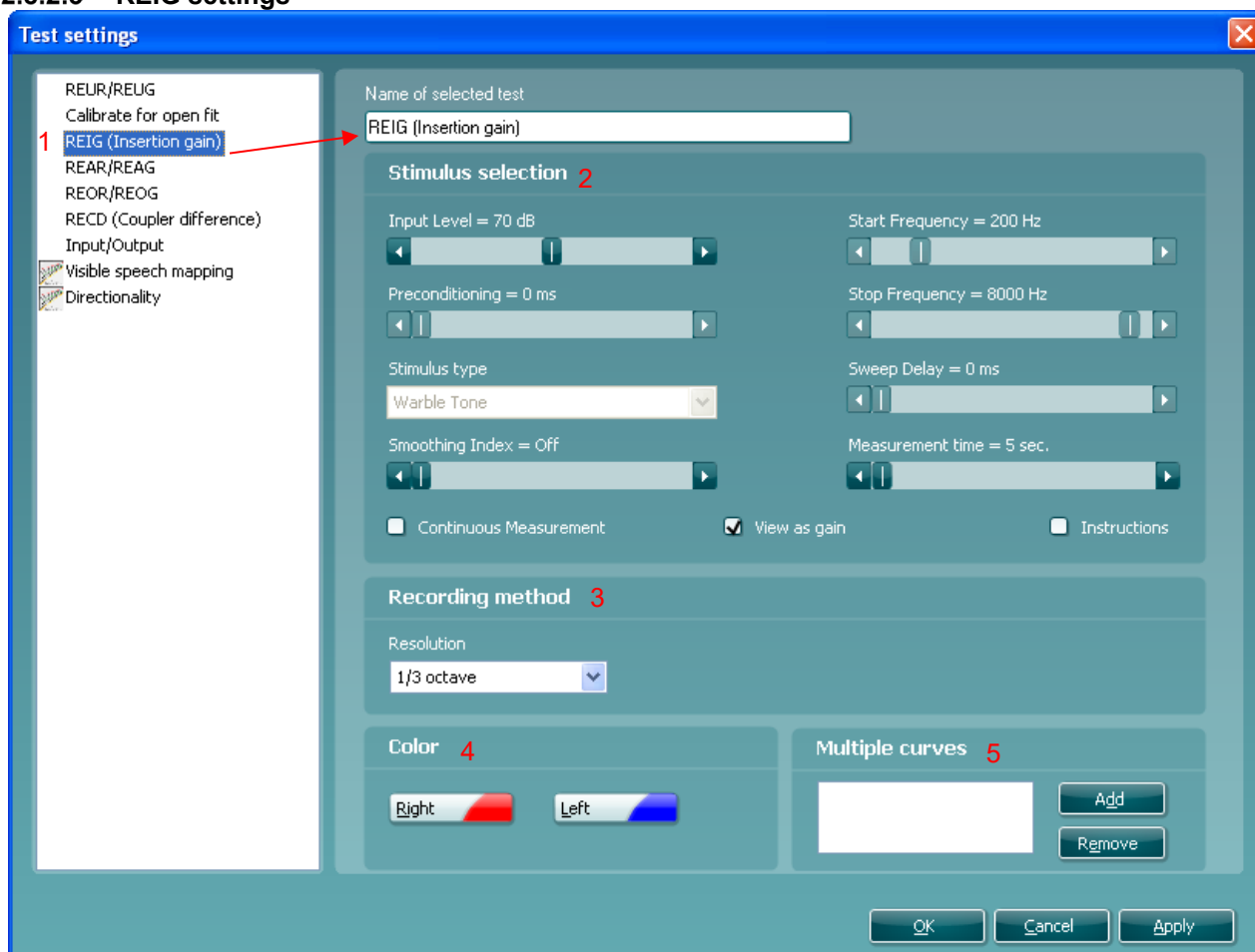

- 1) Ensure that **REIG** is marked in the left-hand side of the screen. The name of the test will then appear in the *Name of selected test* section.
Note the option to write a new name for the test in this section (e.g., “REIG 70 dB input”)
- 2) **Stimulus selection:**
 - *Input Level:* Set the input level using the slider.
 - *Smoothing Index:* You have the option to smooth the measured curve using the slider (see section 2.6.11 for details). The higher index number selected the more smoothing is applied.
 - *Continuous:* This check box allows you to make the measurement ongoing rather than a single sweep. This may, however, also be done in the front screen using the continuous button:



When continuous is ticked, the stimulus and recording will continue until you press the STOP button. This can be practical either if you want to change the settings of the hearing aid or observe the changes in hearing aid performance.

- *View as gain:* allows you to view the measurement as a gain curve by default. If you wish to view it as response, ensure that the check box remains unticked (see section 2.6.3 for details regarding Gain versus Response view).
- *Measurement time* (in seconds): Duration for the measurement can be set using the slider. This is only relevant for broad band signals. Several seconds can freely be selected between 1 and 1200. By default, the measurement time is the same for all signals.
- *Instructions:* This allows for adding picture instructions. If the box is ticked an instruction box explaining how to perform the measurement will appear upon pressing START.



Note: *Preconditioning, Stimulus type, Start/Stop frequency, and Sweep delay* are all greyed out for REIG. This is because the REIG is a calculation and not a measurement (REAR/REAG – REUR/REUG = REIG). The stimulus characteristics therefore are tied to the REUR settings. If other stimulus settings are preferred these should be changed in the REUR/REUG test (see section 2.8.2.1). However, even though the REIG stimulus will default to the signal selected for the REUR, it can, however, be changed from the front screen stimulus dropdown list.

3) **Recording method:**

- **Resolution (of frequency):** Select the preferred resolution in the dropdown. The higher the resolution the slower the measurement. Keep in mind that 1/3 is what is used in many hearing aid manufacturers software. If the curve is to be compared to this, you may consider choosing this resolution. Also note that when using a broad band signal the dropdown list will be greyed out and automatically choose FFT. This makes the distance between frequency bins 43 Hz which ensures precision in the measurement.

4) **Color:**

- Select a color for the *Right* and *Left* curve (see section 2.8.2.1 regarding REUR/REUG for details).

5) **Multiple curves:**

- The Multiple curves option, if configured, will run a series of concurrent differing intensity levels when you press start in the test screen. Set the first level using the Input Level slider and press *Add* under Multiple Curves. The level will then appear in the corresponding white section as the Primary intensity. Select the second level and press *Add* again. The new level will then be listed under the first one. If a level is selected by mistake click on it in the white section and press *Remove*.

Additional note for EUHA MPO Signal

Should an MPO sweep need to be performed with EUHA MPO signal, follow the procedure for 2.8.2.2. Then ensure the settings are setup as shown in the image. Note that the name of the test can be edited to MPO signal should the user wish to do so.



Test settings

Name of selected test
MOSPL (85dB pure tone)

Input level = 90 dB

Stimulus type
EUHA-MPO-Signal

Advanced **85 - 90 dB**

Stimulus selection

Preconditioning = 5 s

Start Frequency = 200 Hz

Smoothing index = Off

Stop Frequency = 8000 Hz

Measurement time = 8 sec.

Sweep Delay = 0 ms

Continuous measurement View as gain Instructions

Recording method

Weighted

Off

Color

Right Left

Sequence Icon

Right Left

Multiple curves

Add Remove

Display

Display peaks & valleys Hide target

Percentile analysis

00% 00% 00% 00% 00%

Hide MPO 1/3 octave & overlapping time windows

Percentiles for full measurement Show dynamic compression ratio

Low High

Set settings to IEC 60118-15

OK Cancel Apply



2.8.2.4 RECD settings

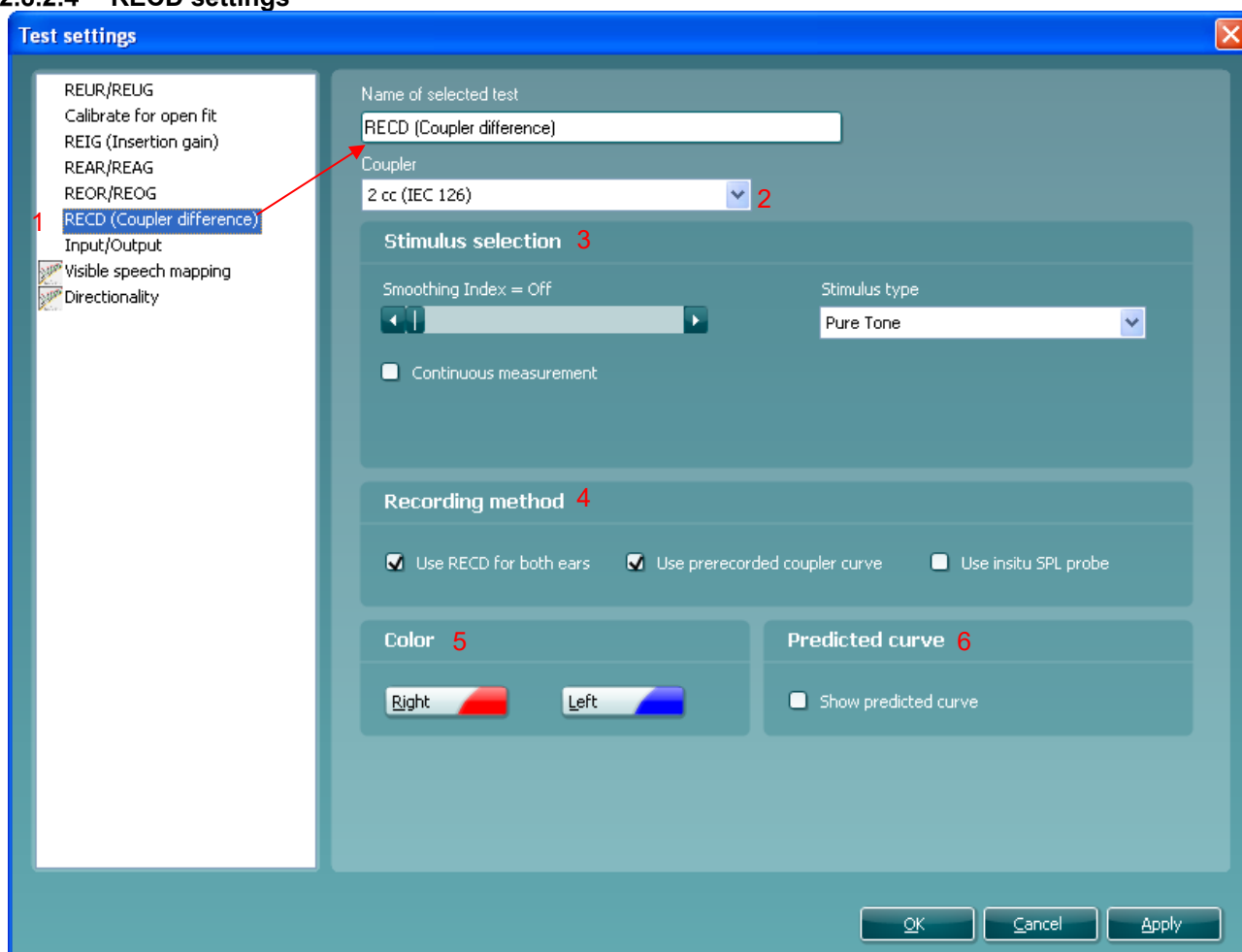

- 1) Ensure that **RECD** is marked in the left-hand side of the screen. The name of the test will then appear in the *Name of selected test* section.
Note the option to write a new name for the test in this section (e.g., “RECD with SPL probe”)
- 2) Select the preferred **Coupler type**.
Choose between:
 - 2cc coupler (IEC 126)
 - Ear simulator (IEC 711)The volume of the IEC 711 is more like the volume of a real ear than the 2-cc coupler.
Note: No predicted values are available for Ear simulator (IEC 711). If selecting Show predicted curve the values displayed on the graph will be based on 2 cc coupler values!
- 3) **Stimulus selection:**
 - *Smoothing Index:* You have the option to smooth the measured curve using the slider (see section 2.6.11 for details). The higher index number selected the more smoothing is applied.
 - *Continuous:* This check box allows you to make the measurement ongoing rather than a single sweep. This may, however, also be done in the front screen using the continuous button:

 - *Stimulus type:* Select a stimulus using the dropdown list. Note that only Pure Tone, Warble Tone, and Pink Noise are available for RECD.



Note: The input level for RECD is fixed at 70 dB. This cannot be changed by the user.

4) **Recording method:**

- *Use RECD for both ears:* Select if one RECD measurement is to be used for both ears.
- *Use pre-recorded coupler curve:* Select this option to use a previously measured coupler curve. This way you only need to perform the ear measure. Note that this function can only be activated for a Pure Tone stimulus.
- *Use SPL probe:* Select to use the SPL probe if your client does not have an ear mould, if the mould is broken or has a bad fit, or if the client is uncooperative (see section for details on RECD with own mould and SPL probe).

5) **Color:**

- Select a color for the *Right* and *Left* curve (see section 2.8.2.1 regarding REUR/REUG for details).

6) **Predicted curve:**

- *Show predicted curve:* Select to use a predicted curve as default using the tick box.

Note: *Instructions* cannot be selected in this screen as these will automatically appear when performing each step of the RECD making sure that the measurement is performed correctly.



2.8.2.5 REOR/REOG settings

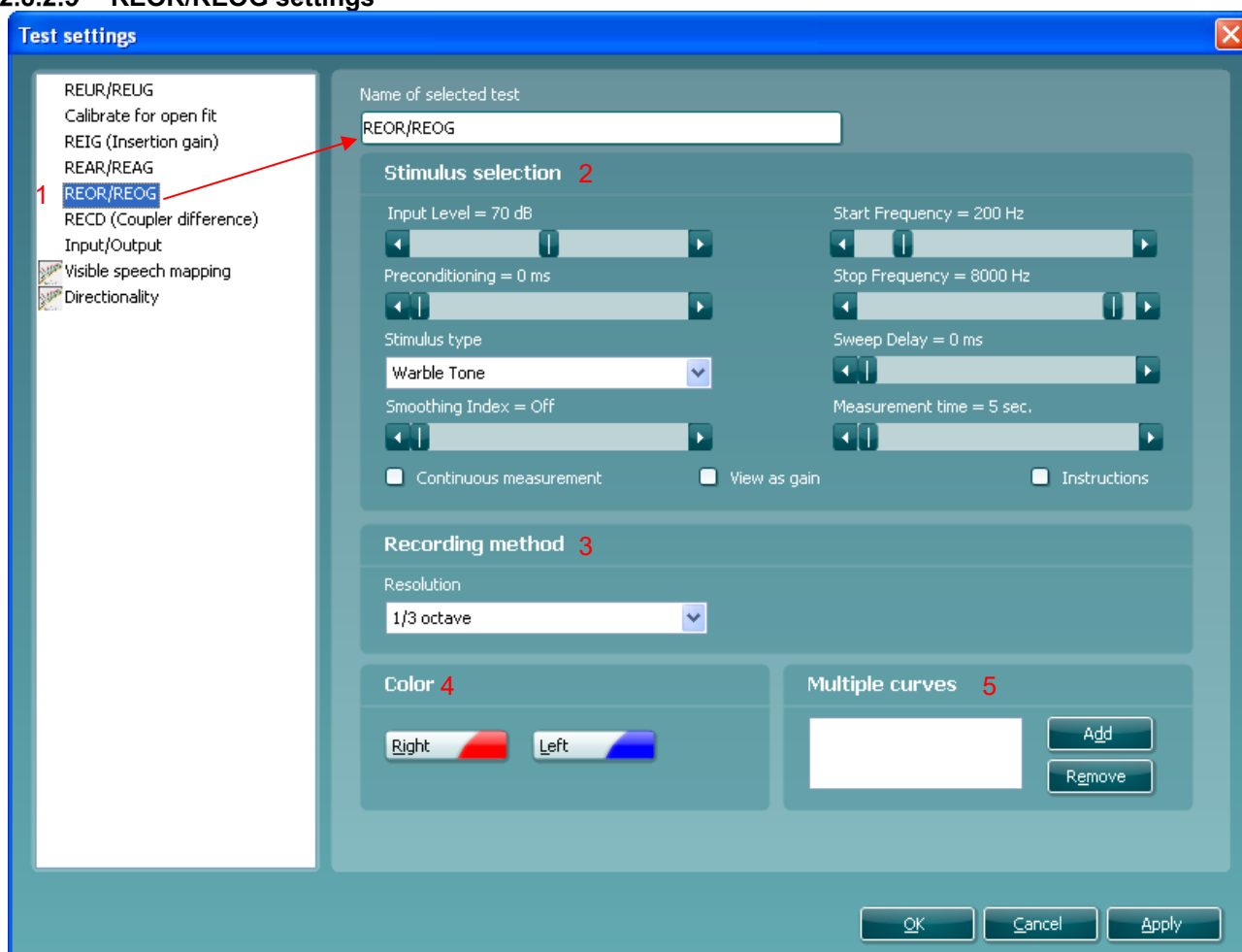

- 1) Ensure that **REOR/REOG** is marked in the left-hand side of the screen. The name of the test will then appear in the *Name of selected test* section. Note the option to write a new name for the test in this section (e.g., “REOR/REOG 70 dB input”)
- 2) **Stimulus selection**
 - *Input Level*: Set the input level using the slider.
 - *Preconditioning*: This is relevant when using broadband signals such as for example ICRA (see section 2.6.10.1 for details). Select a time using the slider.
 - *Stimulus type*: Select a stimulus using the dropdown list.
 - *Smoothing Index*: You have the option to smooth the measured curve using the slider (see section 2.6.11 for details). The higher index number selected the more smoothing is applied.
 - *Continuous*: This check box allows you to make the measurement ongoing rather than a single sweep. This may, however, also be done in the front screen using the continuous button:



When continuous is ticked, the stimulus and recording will continue until you press the STOP button. This can be practical either if you want to change the settings of the hearing aid or observe the changes in hearing aid performance.

- *View as gain* allows you to view the measurement as a gain curve by default. If you wish to view it as response, ensure that the check box remains unticked (see section 2.6.3 for details regarding Gain versus Response view).



- **Start Frequency and Stop Frequency:** Select the preferred frequencies using the sliders. These may for example be set so that they correspond with the hearing aid gain handles (e.g., if the hearing aid goes up to 8000 Hz there is no reason to measure beyond this frequency). To avoid low frequency noise, you may wish to set the slider to a start frequency of 200Hz.
 - **Sweep delays:** This is relevant if *Continuous measurement* is selected for Pure Tone or Warble Tone. In this case sweep delays (in milliseconds) may be entered between the individual sweeps (see section 2.6.10.2 for details).
 - **Measurement time (in seconds):** Duration for the measurement can be set using the slider. This is only relevant for broad band signals. Several seconds can freely be selected between 1 and 1200. By default, the measurement time is the same for all signals.
 - **Instructions:** This allows for adding picture instructions. If the box is ticked an instruction box explaining how to perform the measurement will appear each time upon pressing START.
- 3) Recording method:**
- **Resolution (of frequency):** Select the preferred resolution in the dropdown. The higher the resolution the slower the measurement.
- 4) Color:**
- Select a color for the *Right* and *Left* curve (see section 2.8.2.1 regarding REUR/REUG for details).
- 5) Multiple curves:**
- The Multiple curves option, if configured, will run a series of concurrent differing intensity levels when you press start in the test screen. Set the first level using the Input Level slider and press *Add* under Multiple Curves. The level will then appear in the corresponding white section as the Primary intensity. Select the second level and press *Add* again. The new level will then be listed under the first one. If a level is selected by mistake click on it in the white section and press *Remove*.



2.8.2.6 Input/output settings

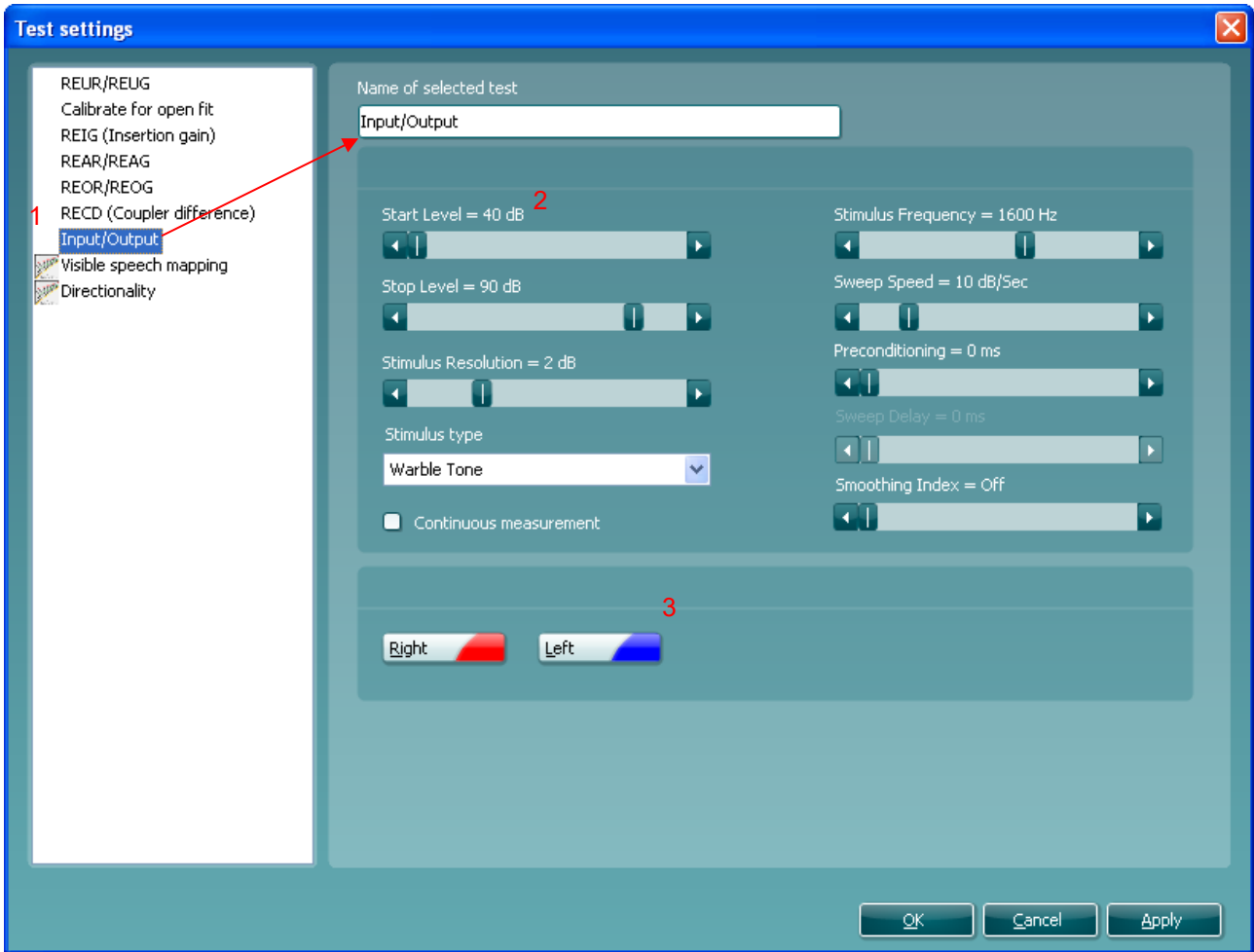

- 1) Ensure that **Input/Output** is marked in the left-hand side of the screen. The name of the test will then appear in the *Name of selected test* section.
Note the option to write a new name for the test in this section (e.g., “Input/Output 1600 Hz”)
- 2) **Stimulus selection**
 - *Start Level/Stop Level*: Set the start and stop level using the sliders.
 - *Stimulus Resolution*: Set the stimulus resolution (1-5 dB) using the slider
 - *Stimulus type*: Select a stimulus using the dropdown list.
 - *Continuous*: This check box allows you to make the measurement on going rather than a single sweep. This may, however, also be done in the front screen using the continuous button:



When continuous is ticked, the stimulus and recording will continue until you press the STOP button. This can be practical either if you want to change the settings of the hearing aid or observe the changes in hearing aid performance.

- *Stimulus frequency*: Select the frequency at which the test should be performed.
- *Sweep Speed*: Set the sweep speed (in dB per second) using the slider. The sweep speed will affect the measured curve since different hearing aids will react differently to a certain speed. A high-quality hearing aid will for example most likely have a faster reaction time.
- *Preconditioning*: This is relevant when using broadband signals such as ICRA (see section 2.6.10.1 for details). Select a time using the slider.



- *Sweep delays*: This is relevant if *Continuous measurement* is selected for Pure Tone or Warble Tone. In this case sweep delays (in milliseconds) may be entered between the individual sweeps (see section 2.6.10.2 for details).
 - *Smoothing Index*: You have the option to smooth the measured curve using the slider (see section 2.6.11 for details). The higher index number selected the more smoothing is applied.
- 3) **Color:**
- Select a color for the *Right* and *Left* curve (see section 2.8.2.1 regarding REUR/REUG for details).



2.8.2.7 Directionality settings

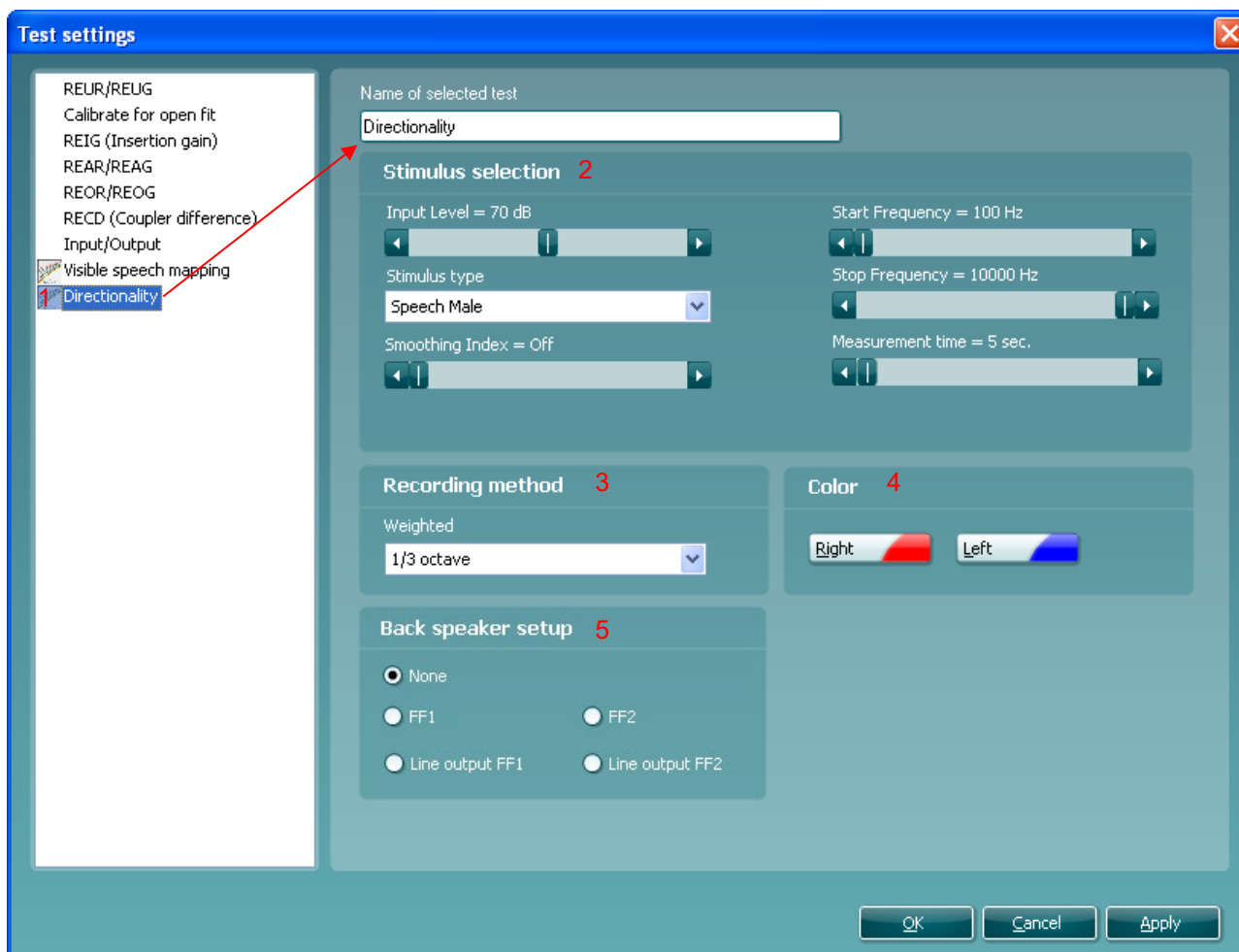

1. Ensure that **Directionality** is marked in the left-hand side of the screen. The name of the test will then appear in the *Name of selected test* section.
Note the option to write a new name for the test in this section (e.g., “Directionality check”)
2. **Stimulus selection**
 - *Input Level*: Set the input level using the slider.
 - *Stimulus type*: Select a stimulus using the dropdown list.
 - *Smoothing Index*: You have the option to smooth the measured curve using the slider (see section 2.6.11 for details). The higher index number selected the more smoothing is applied.
 - *Start Frequency* and *Stop Frequency*: Select the preferred frequencies using the sliders. These may for example be set so that they correspond with the hearing aid gain handles (e.g., if the hearing aid goes up to 8000 Hz there is no reason to measure beyond this frequency). To avoid low frequency noise, you may wish to set the slider to a start frequency of 200Hz.
 - *Measurement time (in seconds)*: Duration for the measurement can be set using the slider. This is only relevant for broad band signals. Several seconds can freely be selected between 1 and 1200. By default, the measurement time is the same for all signals.
- 3) **Recording method:**
 - *Resolution (of frequency)*: Select the preferred resolution in the dropdown. The higher the resolution the slower the measurement.
- 4) **Color:**
 - Select a color for the *Right* and *Left* curve (see section 2.8.2.1 regarding REUR/REUG for details).



5) **Back speaker setup:**

- Select which speaker should be used for the back microphone measure.
You have the option to select a free field loud speaker instead of the Callisto™ loudspeaker. In this case the client does not need to be turned around after measuring the front microphone. Note that if you are using the Callisto™ loudspeaker, select *None*.



2.8.2.8 Pause settings

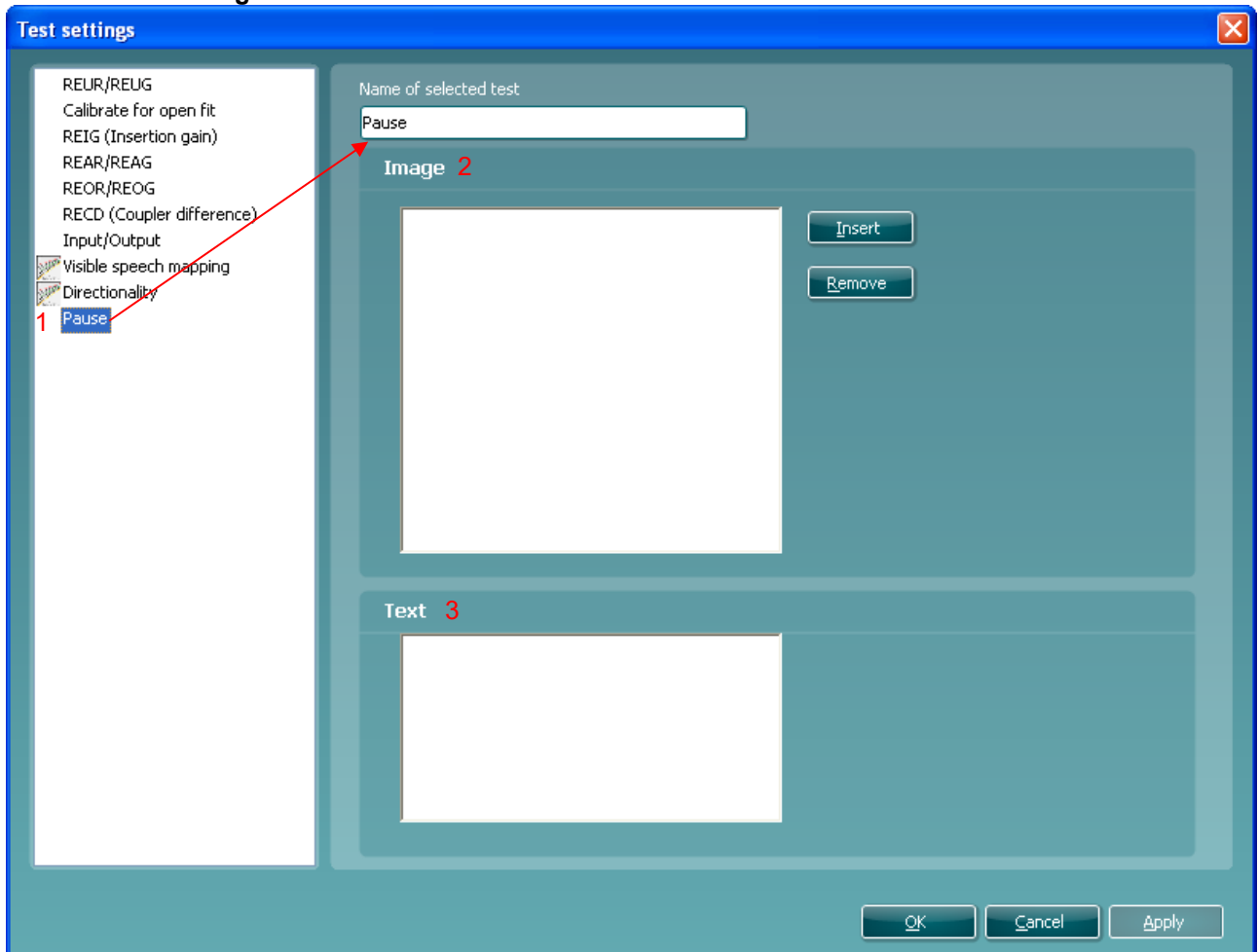

You have the option to implement a pause in your individual test protocol. This way you can create a reminder if needed during the testing.

- 1) Ensure that **Pause** is marked in the left-hand side of the screen. The name of the test will then appear in the *Name of selected test* section.
Note the option to write a new name for the test in this section (e.g., enable reference test gain)
- 2) **Image:**
 - *Insert:* Press *Insert* to browse for an instructional/reminder picture to appear on the screen during the pause.
 - *Remove:* Press *Remove* to delete a selected picture.
- 3) **Text:**
 - Write a test to appear during the pause in the white section.

2.8.2.9 Visible speech mapping settings

Visible Speech Mapping is added to a protocol and adjusted using the same procedures as for other tests (see sections 2.8.2.1 - 2.8.2.7 above). This is further described in section 2.112 about Visible Speech Mapping.



2.8.3 Combined screen setup

REM440 can be setup for default curve comparisons. This is done in the *Combined screen settings* menu.

- 1) To enter the *Combined screen settings* menu, select your protocol in the *Select protocol* dropdown list in the main setup.

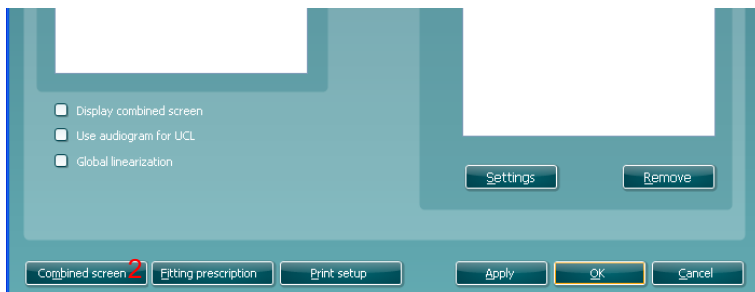

- 2) Click on the *Combined screen* button. This will prompt the combined screen setup below:

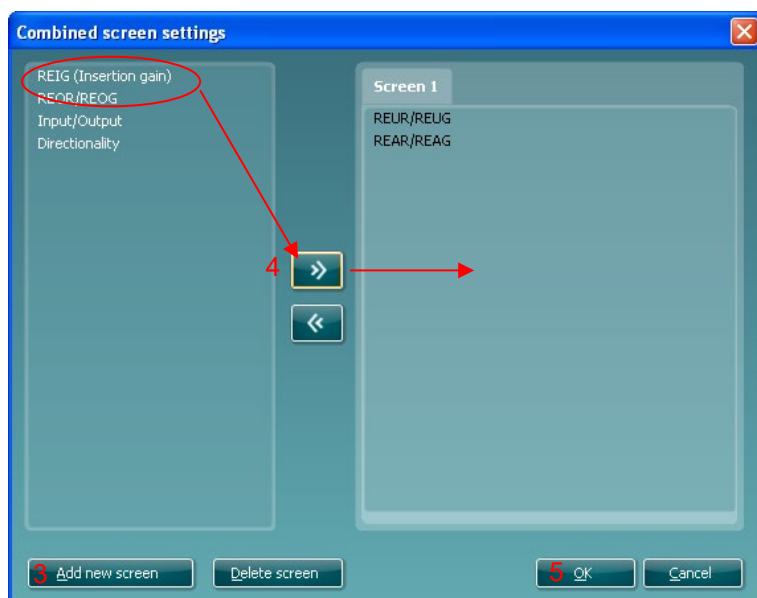

- 3) To create a default curve comparison view, click on *Add new screen*. A tab will then appear in the upper part of the screen.
- 4) Use the arrows to move the measurements to be compared (listed to left) to the new screen. If preferred, you can add several new comparison screens.
- 5) When finished click **OK** to return to the main setup.

Note: Before closing the setup remember to tick the *Display combined screen* check box for the combined screen settings to be active.

When a combined screen view is setup, you can click on the *Toggle between single and combined screen* button in the front screen to view the desired curves together:



If no combined screen view is setup *Toggle between single and combined screen* will show all measured curves.



2.8.4 Fitting prescription setup

REM440 can be setup to use a specific fitting prescription by default.

- 1) To enter the *Fitting prescription settings* menu, select your protocol in the *Select protocol* dropdown list in the main setup.

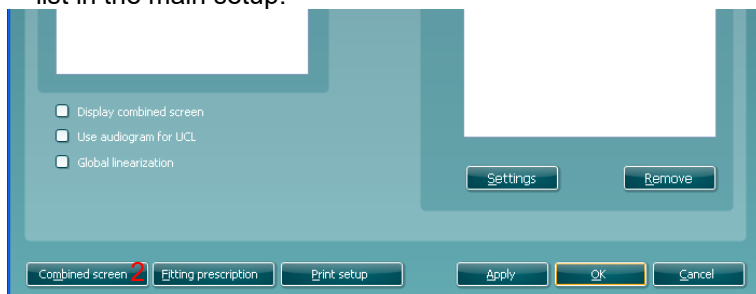

- 2) Click on the *Fitting prescription settings* button.

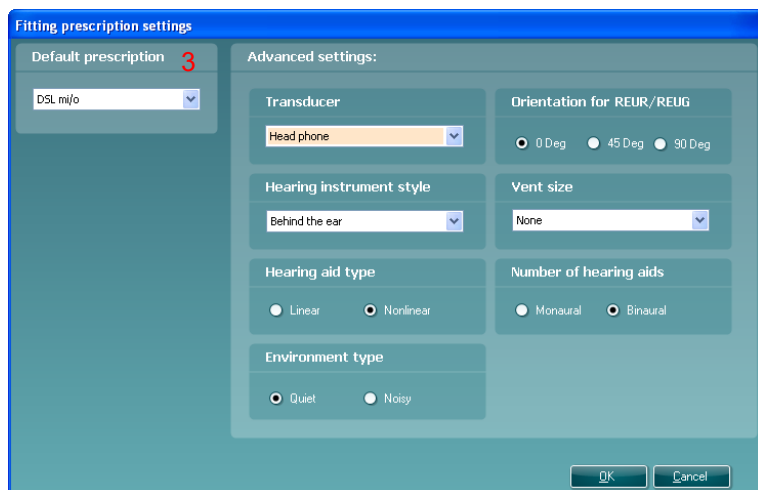

- 3) **Default prescription:**

- Select the default fitting prescription. Choose between *Berger*, *DSL m[i/o]*, *Half Gain*, *NAL-NL1*, *NAL-NL2*, *NAL-R*, *NAL-RP*, *POGO1*, *POGO2*, and *Third Gain*.



Note: Multiple options are available when selecting NAL-NL1/NAL-NL2, or DSL *m[i/o]* and that the selections differ depending on the fitting prescription chosen. Also note that REIG targets are available for all fitting prescriptions whereas NAL-NL1/NAL-NL2 and DSL *m[i/o]* also provide REAR/RE AG targets.

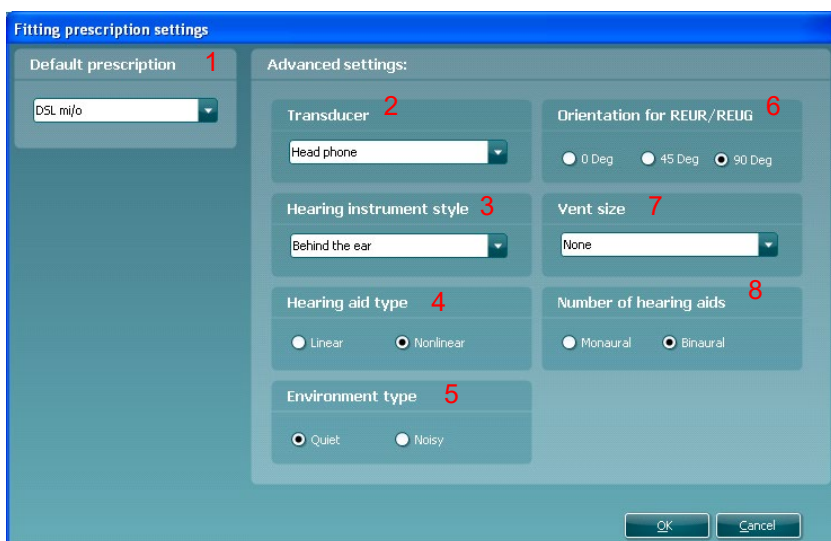

2.8.4.1 DSL

DSL*m[i/o]* settings

- 1) **Default prescription:**
 - Select DSL *mi/o*. Note that the version implemented is DSL *mi/o* v5.0a.
- 2) **Transducer:**
 - Choose the type of transducer used for the audiometry. Select between *Head phone*, *Insert*, *Insert + mould*, *Sound field 0 deg.*, *Sound field 45 deg.*, *Sound field 90 deg.*, and *ABR estimated hearing level*. This will affect the threshold indications and thereby the target calculation.
- 3) **Hearing instrument style:**
 - Select the type of hearing aid the client is fitted with. Choose between *Behind the ear*, *In the canal*, *In the ear*, *Body style*, *Deeply inserted completely in the canal*, and *Shallow completely in the canal*. This will add a correction to the measurement during RECD based verification in the test box.
- 4) **Hearing aid type:**
 - Choose the type of amplification. Select between *Linear* and *Nonlinear* using the check boxes.
- 5) **Environment type:**
 - Select the environment in which the measurement is performed. Choose between *Quiet* and *Noisy*. For example, an air conditioner may affect the measured curve in which case the target should be higher.
- 6) **Orientation for REUR/REUG:**
 - If using a predicted REUR/REUG select orientation. Choose between *0 Deg*, *45 Deg*, and *90 deg* using the check boxes.
- 7) **Vent size:**
 - Set the vent size of the hearing aid using the dropdown. Select between *None*, *1 mm*, *2 mm*, *3,5 mm*, *Custom*, and *Open*.
- 8) **Number of hearing aids:**
 - Set whether the fitting is *Monaural* or *Binaural* using the tick boxes.



2.8.4.2 NAL-NL2 settings

- 1) **Default prescription:**
 - NAL-NL2.
- 2) **Transducer:**
 - Choose the type of transducer used for the audiometry. Select between *Head phone*, *Insert*, *Insert + mould*, *Sound field 0 deg.*, and *sound field 45 deg.* This will affect the threshold indications and thereby the target calculation.
Note: It is important to choose the correct settings in this dropdown. E.g., if your audiogram is done in head phones but inserts are selected as transducer, no target will be calculated.
- 3) **Hearing instrument style:**
 - Select the type of hearing aid the client is fitted with. Choose between *Behind the ear*, *In the canal*, *In the ear*, and *Completely in the canal*. This will add a correction to the measurement during RECD based verification in the test box.
- 4) **Hearing aid type:**
 - Choose the type of amplification. Select between *Linear* and *Nonlinear* using the check boxes.
- 5) **Tubing:**
 - Select the hearing aid tubing. Choose from *Libby 4*, *Libby 3*, *#13*, *Thin Tube*, *RITC (receiver in the canal)*
- 6) **Limiting:**
 - Set the limiting to *Off*, *Wide-band*, and *Multi-band*. Multi-band will automatically be selected as standard.
Note that limiting information regarding individual hearing aids may be found in the manufacturers' specification sheets or by contacting the manufacturer.
- 7) **Compression speed:**
 - Compression speed is used for determining the compression ratio which is lowered for fast acting compressions for severe/profound hearing losses (making the fluctuations in the signal more obvious) for this group of users.
Select between *Slow (<50ms)*, *Dual* (Intermediate or dual/adaptive compression), or *Fast (>300ms)*.
- 8) **Orientation for REUR/REUG:**
 - If using a predicted REUR/REUG select the orientation. Choose between *0 Deg*, *45 Deg*. using the check boxes. *90 Deg* is not available for NAL-NL2



- 9) **Vent size:**
 - Set the vent size of the hearing aid using the dropdown. Select between *Tight*, *Occluded*, *1 mm*, *2 mm*, *3 mm*, and *Open*.
- 10) **Number of hearing aids:**
 - Set whether the fitting is *Monaural* or *Binaural* using the tick boxes
- 11) **Threshold (dB)**
 - Type in the preferred knee-point in the white section which is set to 50 by default
- 12) **Audiogram type**
 - Select to use bone conduction values in the target calculation.
- 13) **Language**
 - Select the type of language: Tonal or Non-Tonal. This will add a correction to the target calculation based on whether a language is tonal (like many Asian languages) or non-tonal (like many European languages).
- 14) **REUR/REUG used**
 - Select from the drop down menu whether measured or predicted REUG should be used. Should "Measured" be selected when you start your REM, a prompt will appear indicating "No REUG/REUR measured" if one has not been measured,

2.8.4.3 NAL-NL1 settings

Fitting prescription settings

Default prescription

NAL-NL1

Advanced settings:

Transducer
Head phone

Orientation for REUR/REUG
 0 Deg 45 Deg 90 Deg

Hearing instrument style
Behind the ear

REUR/REUG used
Predicted

Tubing
Libby 4

Audiogram type
 Use Bone values

Vent size
Occluded

Number of hearing aids
 Monaural Binaural

Limiting
 Off Wide-band Multi-band

Threshold (dB)
Wide band compression threshold (Hearing aid knee-point) level: 50

OK Cancel

1. **Default prescription:**
 - NAL-NL1.
2. **Transducer:**



- Choose the type of transducer used for the audiometry. Select between *Head phone*, *Insert*, *Insert + mould*, *Sound field 0 deg.*, and *sound field 45 deg.* This will affect the threshold indications and thereby the target calculation.
Note: It is important to choose the correct settings in this dropdown. E.g., if your audiogram is done in head phones but inserts are selected as transducer, no target will be calculated.

3. Hearing instrument style:

- Select the type of hearing aid the client is fitted with. Choose between *Behind the ear*, *In the canal*, *In the ear*, and *Completely in the canal*. This will add a correction to the measurement during RECD based verification in the test box.

4. Hearing aid type:

- Choose the type of amplification. Select between *Linear* and *Nonlinear* using the check boxes.

5. Tubing:

- Select the hearing aid tubing. Choose from *Libby 4*, *Libby 3*, *CFA#2 Horn*, *CFA#3 stepped bore*, *#13,6CS*, *6C10*, *None*.

6. Limiting:

- Set the limiting to *Off*, *Wide-band*, and *Multi-band*. Multi-band will automatically be selected as standard.

Note that limiting information regarding individual hearing aids may be found in the manufacturers' specification sheets or by contacting the manufacturer.

7. Orientation for REUR/REUG:

- If using a predicted REUR/REUG select orientation. Choose between *0 Deg* and *45 Deg* using the check boxes. *90 Deg* is not available for NAL-NL2

8. Vent size:

- Set the vent size of the hearing aid using the dropdown. Select between *Tight*, *Occluded*, *1 mm*, *2 mm*, *3 mm*, and *Open*.

9. Number of hearing aids:

- Set whether the fitting is *Monaural* or *Binaural* using the tick boxes

10. Threshold (dB)

- Type in the preferred knee-point in the white section which is set to 50 by default

Audiogram type

- Select to use bone conduction values in the target calculation.

11. REUR/REUG used

- Select from the drop down menu whether measured or predicted REUG should be used. Should "Measured" be selected when you start your REM, a prompt will appear indicating "No REUG/REUR measured" if one has not been measured

2.8.4.4 Print layout settings

The REM440 module allows for setting up individual print layouts. This is done in the Print Wizard which is entered using the Print Wizard button (read about the Print Wizard in section **Error! Reference source not found.**).





2.8.5 Finishing the test protocol

Press OK in the lower right-hand corner of the AC440 setup screen to save the customized test protocol. The test protocol can then be found in the **List of Protocols** dropdown list on the front screen.

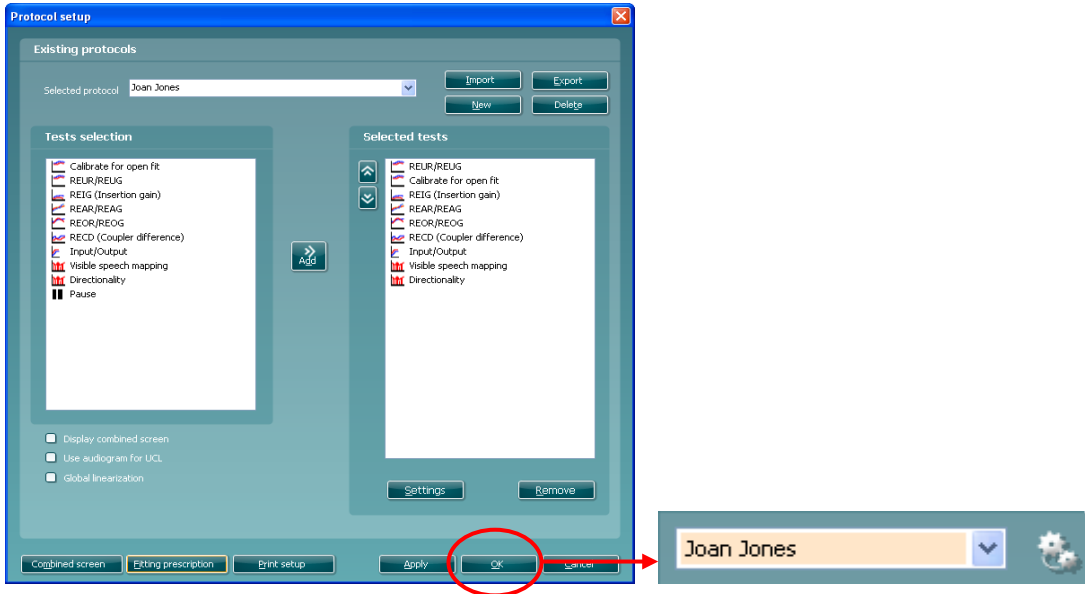



2.8.6 Changing a test protocol permanently

You can at any time make changes to an individual test protocol by entering the REM440 setup again as when creating the test (**Menu/Setup/REM440 setup**).

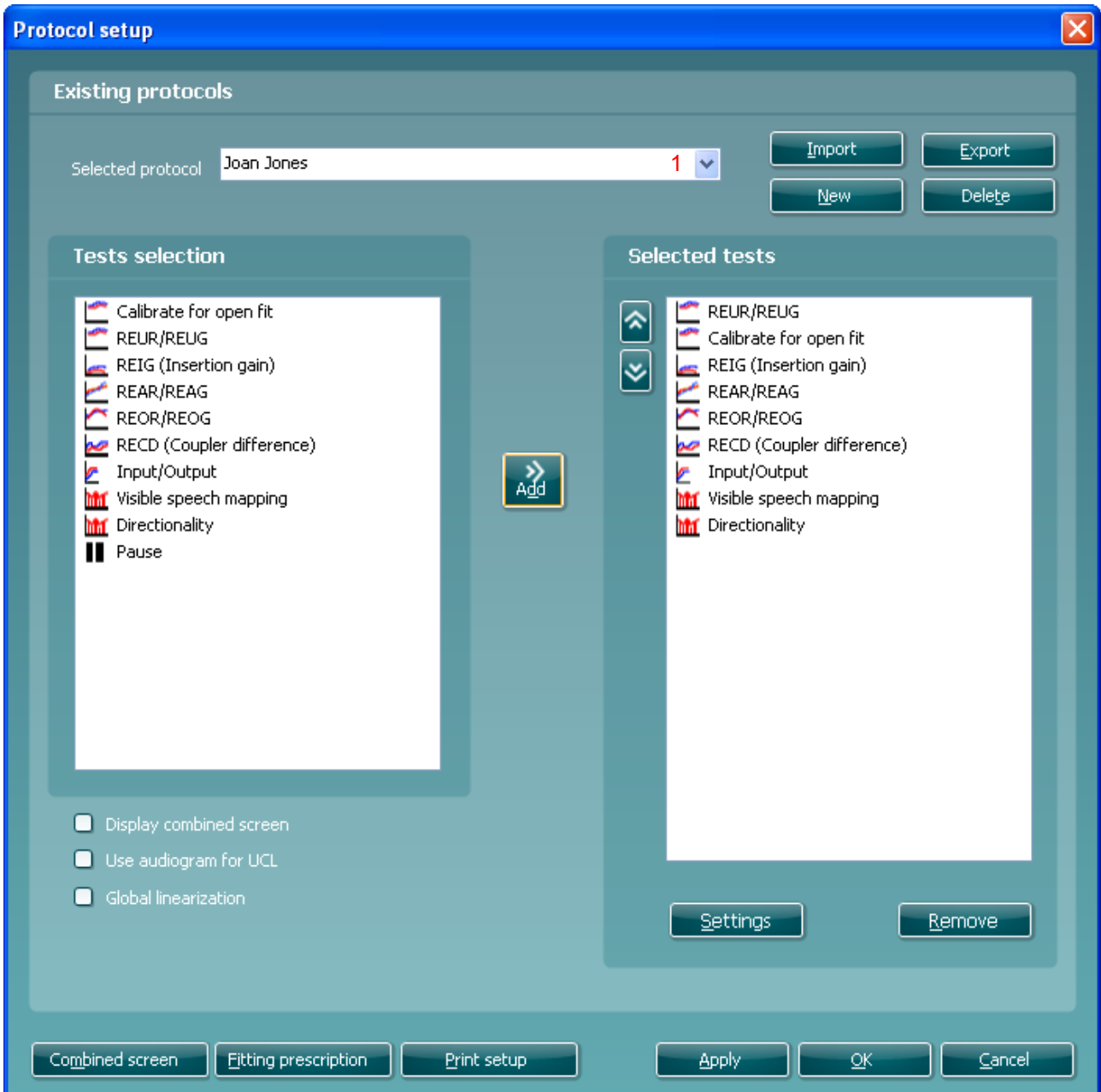

- 1) Choose your test protocol in the *Selected protocol* dropdown list.
- 2) Browse the setup options as if creating a test protocol (see section 2.8.2).
- 3) When finished click **OK** (or **Apply**) to save the changes.



2.8.7 Changing a test protocol temporarily

You may from time to time run into a client with special requirements for advanced or different testing parameters. In this situation the *Temporary Setup* can be helpful. The setup changes made here will be specific to the session. The test protocol name will be supplemented with an asterisk (*) to indicate that changes have been made to original test protocol. After saving, the protocol will revert to the default selected protocol making you ready for your next client.



Enter the *Temporary Setup* by clicking the button in the front screen  (or alternatively select **Menu/Setup/Temporary setup**).

2.8.8 Importing and exporting test protocols

The REM440 also allows you to import and export test protocols to other REM440 users.

2.8.8.1 Importing a test protocol

- 1) Go to REM440 Setup (**Menu/Setup/REM440 Setup**)
- 2) Click **Import** and browse to the location on the PC or USB where the test protocol file has been saved.

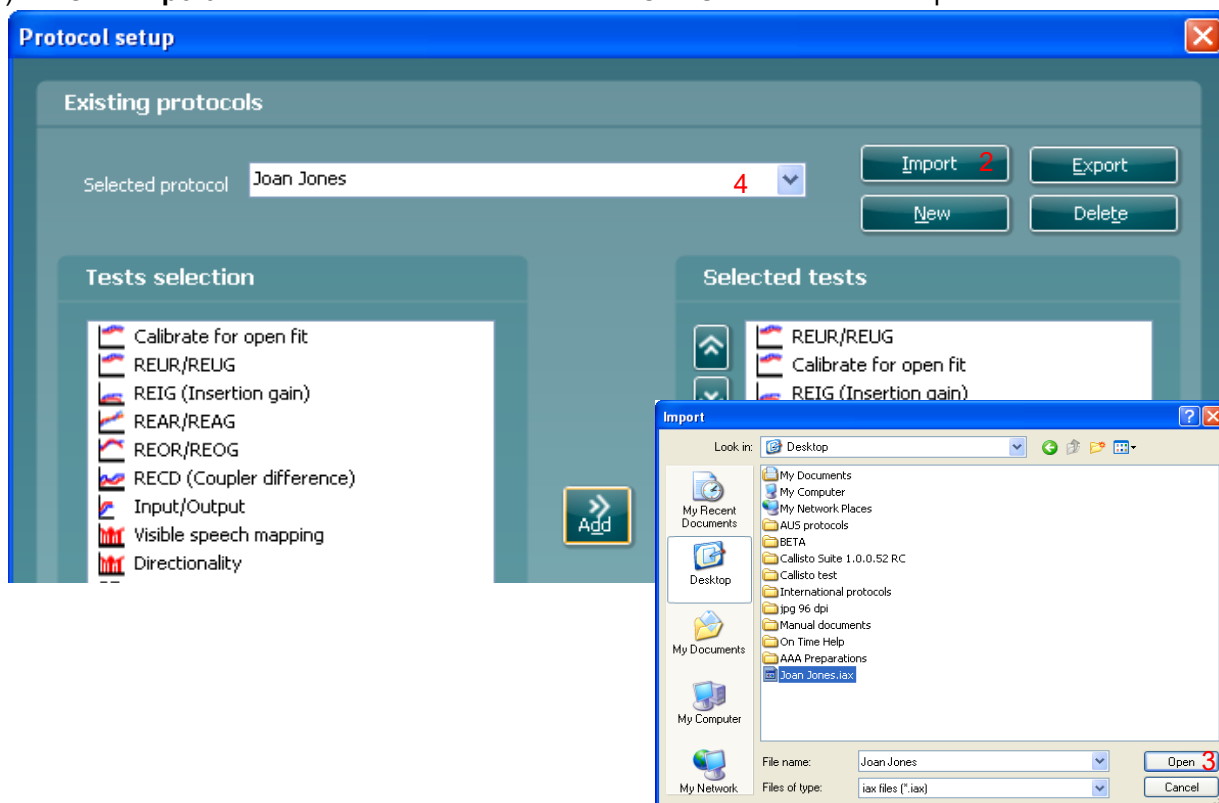

- 3) Click **Open**.
- 4) The test protocol will then appear under **Selected Protocol**. After saving it by clicking **OK** the test protocol can be selected in the **List of Protocols** on the front screen.



2.8.8.2 Exporting a test protocol

- 1) Go to REM440 setup (**Menu/Setup/REM440 setup**).
- 2) **Click on Export.**
- 3) Select if the file is to be saved as “read only”. In this case the protocol file is locked and the clinician receiving it will not be able to make changes to it.

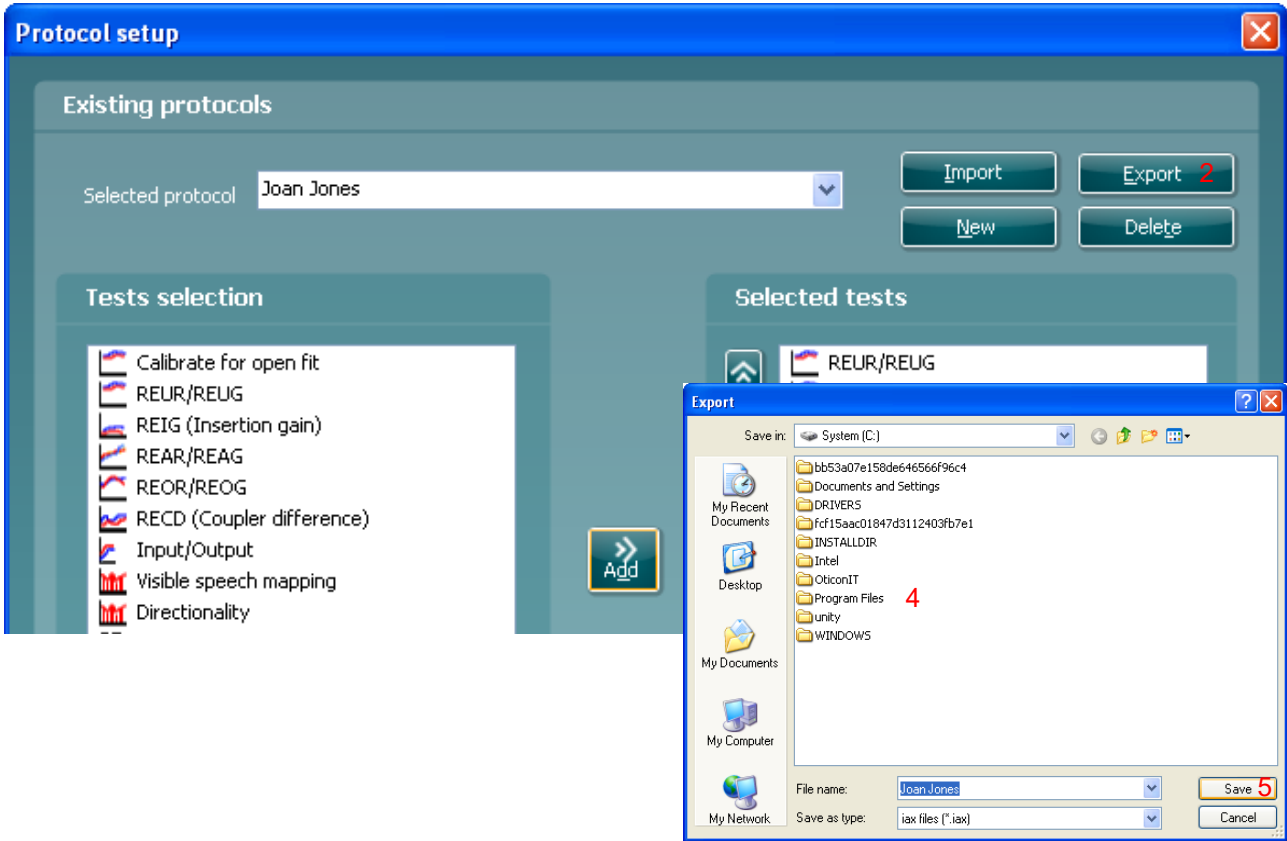

- 4) Browse for the location on the PC or USB where the test protocol is to be placed.
- 5) Click **Save**. Other REM440 users will then be able to upload the test protocol using the Import function.



2.9 General setup

In the *General Setup* you can select overall settings which are valid for all tests.

1. To enter the General setup, select **Menu/Setup/General Setup**

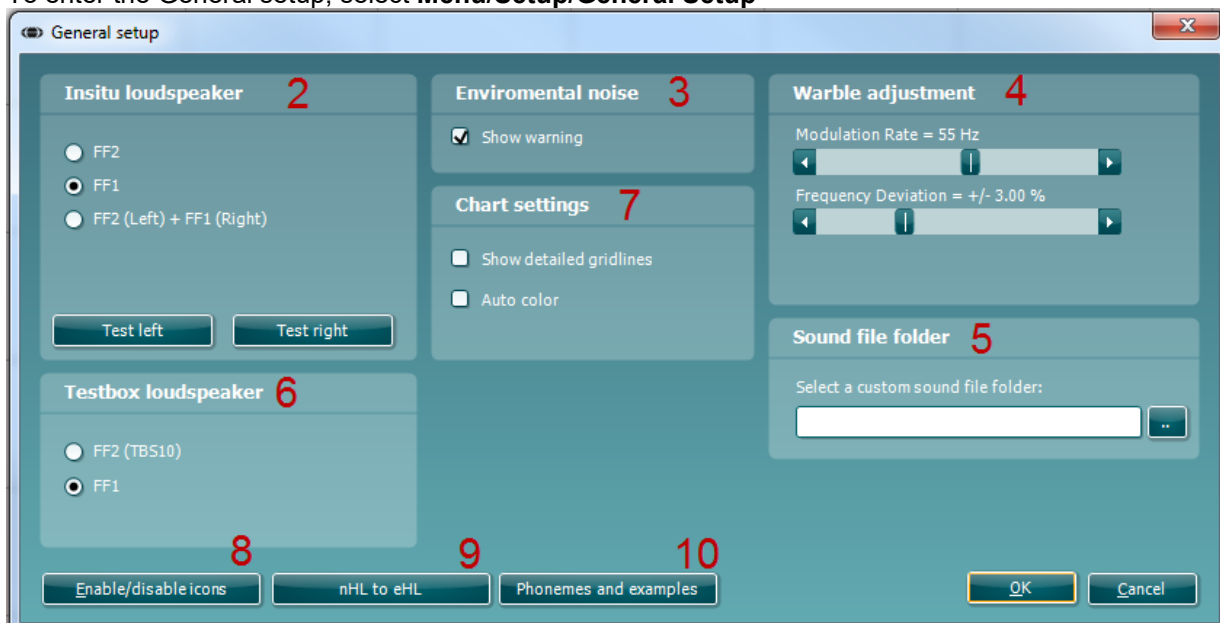

2. **In-situ loudspeaker:**

Select the speaker output through which the stimuli for the real-ear measurements are presented.

- *FF2* or *FF1*: If using the Callisto™ with one external free field loudspeakers select *FF1* or *FF2* and plug the speaker into the corresponding outputs on the FF cable.
- *FF2 (Left) + FF1 (Right)*: If you wish to use *FF2* for the left ear and *FF1* for the right ear select *FF2 (Left) + FF1 (Right)* this can be done if you are using multiple loudspeakers for the REM measurement. These speakers are plugged into their corresponding outputs on the FF cable.

3. **Environmental noise**

- *Show warning*: Ticking this option will prompt the software to show a warning screen if the ambient noise in the environment reaches a level which can affect the measurement.

4. **Warble adjustment:**

- *Modulation Rate*: Select a modulation rate for Warble Tone stimuli (in Hz) using the slider.
- *Frequency Deviation*: Select a frequency deviation for Warble Tone stimuli (in %) using the slider.

5. **Sound file folder:**

- If you prefer to use a stimulus not found in the REM440 stimulus selection you can use other sound files saved on your PC via the Sound File Folder. Press the button to browse for the files on the PC. Note that the files need to be in .wav format, have a sample frequency of 44100 Hz, and a resolution of 16 bit. Both mono and stereo files can be used.

6. **Test box loudspeaker:**

Select the preferred coupler test box for coupler verification.

- *FF2*: This option refers to connected TBS10 test box when you have both the TBS10 test box, and a loudspeaker connected via the FF cable.
- *FF1*: This refers to the TBS10 test box when it is connected directly into the FF output without the FF cable.



7. Chart settings:

- **Show detailed gridlines:** Tick this option to have detailed gridlines on the graph as illustrated below:

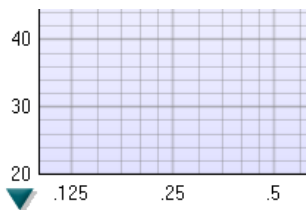

- **Auto color:** Tick this option to have the system automatically pick a new color for each measured curve.

- **Latest curve view:** When you run a new measurement each time, only the latest curve will show and all other measurement curves will be hidden. These hidden curves can be viewed in the right hand menu

- **Show detailed delta values:** Delta values will show on standard octave curves, unless "Show detailed delta values" is checked. Note: These detailed delta values will only show on a monitor size that is big enough to show them, regardless of whether the box is checked or not.

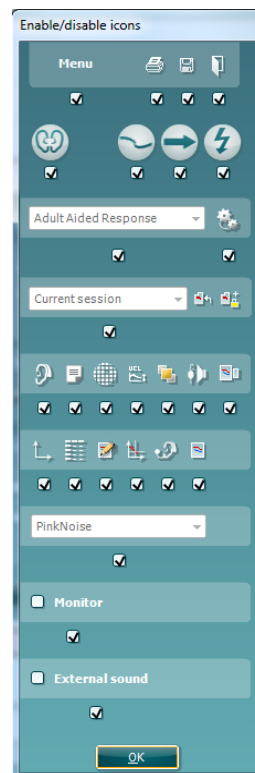

8. Show hide icons:

Press the button to customize the test screen. Use the tick boxes to decide which buttons and dropdown lists should be available from the front screen.

9. nHL to eHL

This section allows you to input a custom nHL to eHL conversion.

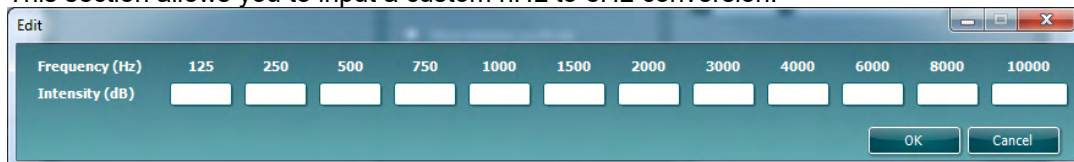





10. Phonemes and examples

This section allows the user to customise and add further phonemes or imagery to the overlays which are used in visible speech mapping.



Phonemes and examples

Phonemes				Examples		
Phoneme	Frequency	Intensity		Example	Frequency	Intensity
m	370	47	<input type="checkbox"/>		3000	98
b	465	42	<input type="checkbox"/>			
n	465	48	<input type="checkbox"/>			
d	540	45	<input type="checkbox"/>			
ng	472	53	<input type="checkbox"/>		6000	29
e	470	58	<input type="checkbox"/>			
l	560	57	<input type="checkbox"/>			
u	520	63	<input type="checkbox"/>		7000	106
i	750	47	<input type="checkbox"/>			
o	850	52	<input type="checkbox"/>			
a	900	46	<input type="checkbox"/>			
r	1030	50	<input type="checkbox"/>			
ø	500	75	<input type="checkbox"/>		1000	40

New phoneme New example OK Cancel



2.10 The REM 440 menu items

The REM440 Menu gives you access to **File, Edit, View, Mode, Setup, and Help.**

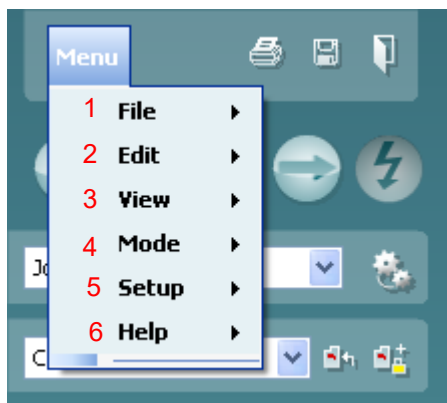

1) Menu/File

- **Menu/File/Print** will prompt the system to print using the selected print template (see section **Error! Reference source not found.**)
- **Menu/File/Print Preview** prompts a print preview of the current protocol using the print template which is linked to the current protocol. Note that you are prompted to select a template if the protocol did not include a template (see how to create a print layout in section 4.1.1)
- **Menu/File/Print Layout** opens the print wizard window from where you can select or create a template to print the current protocol (see section **Error! Reference source not found.** for details regarding the Print Wizard).

2) Menu/Edit

- **Menu/Edit/Delete** will prompt the system to delete the selected curve.
- **Menu/Edit/Delete all** will prompt the system to delete all measured curves.
- **Menu/Edit/Export** will prompt the system to export the session as an XML formatted file.
- **Menu/Edit/Session information** will prompt a window where you can type in your own data regarding the test situation. The text will be specific for each session.

3) Menu/View

- **Menu/View/Combined screen** will activate the combined screen view function (see section 2.6.13.3)
- **Menu/View/Left ear** will activate the left ear in the front screen.
- **Menu/View/Right ear** will activate the right ear in the front screen.
- **Menu/View/Both Ears** will activate both ears at the same time in the front screen (this can also be obtained by right clicking on the ear icon)
- **Menu/view/Save window position** will save the current position of the REM440 window on the PC screen so that it opens at this exact position every time. This is for example practical if you are usually running and viewing other software modules (such as fitting software) at the same time. Using this function for moving and/or resizing of the REM440 will only be necessary once. Note that on-top mode is also available (see section 2.6.8.1)

4) Menu/Mode

- **Menu/Mode/Single measurement** will set the system to present the selected stimulus as a single sweep.
- **Menu/Mode/Continuous measurement** will set the system to present the selected stimulus continuously.
- **Menu/Mode/Probe placement** will activate the probe tube placement tool. If uncertain about the placement of the probe tube the probe tube placement tool may be of assistance. Pressing the button will prompt a 6000 Hz tone. When the column is as low as possible, mark this position on the probe, add 10 mm and a correct probe placement (3-6 mm from the ear drum) will be obtained (Sullivan 1988). Press the button again when finished.



5) Menu/Setup

- **Menu/Setup/REM440 setup** opens the REM440 where you can setup customised test protocols (see section **Error! Reference source not found.** for details)
- **Menu/Setup/General setup** opens the General setup where settings valid for all tests can be selected (see section 2.9 for details)
- **Menu/Setup/Temporary setup** opens the Temporary setup where temporary settings for the specific session can be selected (see section 2.8.77 for details)
- **Menu/Setup/Password protection** allows you create or change a password and thereby protect your REM440 settings. Press *Change password* and type in the preferred password. Then press OK. Note that your password needs to be activated in *Protected settings* under Menu/setup/General setup (see section 2.9).

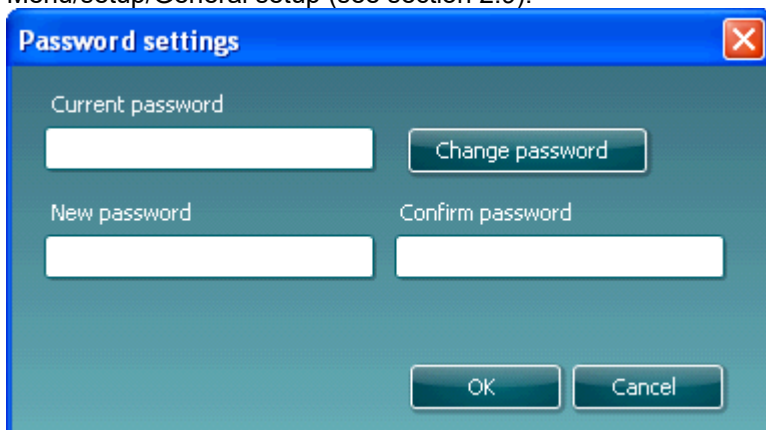

- **Menu Setup/Show/hide protocols** prompts a screen allowing you to tick test protocols which are to be shown in the *List of Protocols* and untick the test protocols which are to be hidden.
- **Menu/Setup/Show/hide stimuli** prompts a screen allowing you to tick which stimuli are to be shown in the Stimulus selection drop down list and untick the stimuli which are to be hidden.
- **Menu/Setup/Language** opens the language selection. Choose from *English, German, Spanish, French, Finnish, Turkish, Korean, Polish, Italian, Japanese, Portuguese, and Chinese (People's Republic of China)* The system must be restarted for a new language selection to take effect.
- **Menu/Setup/General suite settings** is relevant if the VIOT video otoscope is installed. When the otoscope is connected a tab will appear in the upper right-hand corner of the screen.



If you wish the VIOT tab to show even when the equipment is not connected, tick *Always show VIOT tab* in the General suite settings.



6) Menu/Help

- **Menu/Help/About REM440** prompts a message box showing information regarding the *Suite version*, *Hardware version*, and *Firmware version*. Please note that if experiencing problems with the system this information should be sent to the manufacturer along with the description of the issue. (Your instruments serial number will also be required).
Note: Press **License** to be able to type in a new license code.
- **Menu/Setup/About DSL mi/o** will prompt a reference to University of Western Ontario on the implementation of the DSL *m[i/o]* version 5.0a



2.11 Visible speech mapping (VSPM440)

2.11.1 About visible speech mapping

Visible Speech or Speech Mapping is a term widely used amongst manufacturers of various systems. It covers a kind of verification-, fitting-, counselling- or sales tool that provides a live demonstration of the hearing aid features in a clear layout while the client is wearing the instruments. Visible Speech Mapping addresses the complicated task of explaining clinical and technical issues to people outside audiology.

Interacoustics Visible Speech Mapping is designed to assist you in the important process of fitting and counselling. The system merges verification and counselling into one screen display visualizing the SPL at the ear drum with and without hearing aids respectively. As a result, you can match amplification to target (e.g., DSL mi/o or NAL-NL1/NAL-NL2) on the aided display and at the same time show the benefit of using hearing aids by comparing to the unaided condition. The comprehensive layout showing dynamic range, normal hearing thresholds, and sound examples assists in the process of communicating the measurement results and helping achieve realistic expectations.

Various speech signals can be used with Visible Speech Mapping. The signal can be generated using a live microphone input from the client, their companion, the audiologist, or speech samples can be digitally imported from other sources. For both verification and counselling purposes, calibrated LTASS based speech signals such as ISTS (International Speech Test Signal) are also available. The idea is to present unaided and aided speech information to the hearing-impaired individual.

Visible Speech Mapping is also available in the paediatric fitting. When it is not feasible to do real-ear measures, Visible Speech Mapping can be performed using the individual RECD (Real-Ear-to-Coupler Difference). After measuring the RECD values, the hearing aid is positioned in the test box and verification, or counselling can be performed here using the same principles as for REAR/REIG.

Visible Speech Mapping can be used in all sorts of ways. Clients have very different needs, and this section demonstrates the options offered by the system. The clinician can then tailor the input to meet their individual requirements.

People with hearing loss are entering a whole new world with a terminology all its own. By helping them to absorb and understand what they need to know, Visible Speech Mapping makes counselling and verification a positive experience.

Note: The Visible Speech Mapping system is based on the LTASS (Long Term Average Speech Spectrum) and the concept of time-aligned response for a given percentile of the distribution of short-term band sound pressure level of the speech signal. For each frequency band, the LTASS response is the gain averaged over the stimulus duration. Speech response is established for a given percentile for each 100 ms sample of the speech stimulus. These responses are averaged over the duration of the stimulus presentation.

The system produces an estimated REAR and/or a 2cc coupler response for the LTASS and preferred percentiles of the selected signal. The recommended percentiles are the 30th, 65th and 99th percentiles.

The system employs three LTASS based signals *Male Speech*, *Female Speech*, and *ISTS* (International Speech Test Signal). To get at precise measure, it is highly recommended to use one of these on which the calculations are based. However, other signals can also be employed if preferred by the individual clinician. Live Speech is not an option for verification.



2.12 The visible speech mapping screen



Menu



Right click



Menu provides access to File, Edit, View, Mode, Setup, and Help (see section 2.10)

Print button allows for printing the sessions acquired data

Save & New Session button saves the current session in Noah4 or OtoAccess® and opens a new one.

Save & Exit button saves the current session in Noah4 or OtoAccess® and exits the Suite.

Change Ear button allows you to toggle between right and left ear. Right click on the ear icon to view *both ears*. Right click for binaural testing.

Toggle between single and combined screen button toggles between viewing one or multiple measurements on the same REM graph.

Toggle between single and continuous measurement button toggles between running a single sweep or having a test signal running continuously until pressing STOP.



Freeze curve allows for taking a snapshot of a REM curve when testing with broadband signals. In other words, the curve freezes at a particular moment while the test continues.

Note that if too many curves are frozen on the screen not all will be saved in Noah4 due to imposed limitations.



Select protocol to use from the list allows you to select a test protocol for the current test session (see section 2.8.2 for more information about protocols).



Temporary Setup button allows for making temporary changes to the selected protocol. The changes will be valid for the current session only. After making the changes and returning to the main screen, the name of the protocol will be followed by an asterisk (*).



List of historical sessions accesses historical sessions for comparison purposes (see section 2.6.12).



Go to Current Session button brings you back to current session.



Toggle between coupler and ear button allows you to toggle between real-ear and coupler mode. The icon only becomes active if a RECD measurement is available.



Report Editor button opens a separate window for adding notes to the current session. Note that after saving the session no changes can be added to the report after the date has changed (see section 4.2)



Single frequency button represents an optional manual test that allows for pre-setting hearing aid gain prior to real-ear or coupler testing.

Place the hearing aid in the ear (together with the probe tube) or coupler and press the single frequency button. A 1000 Hz tone will then appear allowing you to see the exact input and output of the hearing aid. Press the button again to end the test.

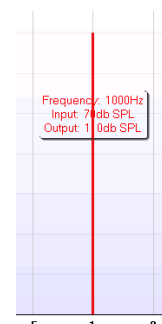

Tube calibration button activates the tube calibration. Before measuring it is recommended to calibrate the probe tube. This is done by pressing the calibration button. Follow the instructions appearing on the screen and press OK. The calibration will then automatically be performed resulting in a curve being drawn. Note that the calibration is sensitive to noise and the clinician should therefore ensure that the room is quite while calibrating.



Normal and reversed coordinate system buttons enable you to toggle between reversed and normal graphs.

This may be helpful for counselling purposes since the reversed curves look more like the audiogram and may therefore be easier for the client to comprehend.



Table view button provides a chart view of the measured and target values

Show cursor on graph provides information about each specific measured point on the curve. The cursor is “locked” to the curve together with frequency and intensity label placed at the cursor’s position, as illustrated below:

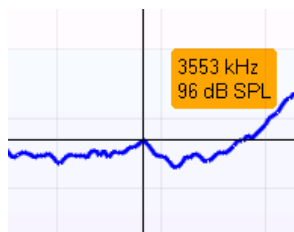

Warble Tone

Stimulus selection dropdown list allows for selecting the test stimulus.

Monitor

Monitor: If you wish to listen to the amplified stimulus through a monitor.

1. Connect a monitor speaker to the monitor output on the hardware.
2. Tick the Monitor check box.
3. Use the slider to turn the sound level up and down.

Note that the sound from the monitor may be very soft (compared to the audiometry monitoring). It is louder for audiometry because the audiometric equipment is producing the signal that is monitored. In REM440 the hearing instrument produces the monitored signal meaning that it cannot be controlled by the equipment. However, if you have an active speaker, it will be louder.

Open Ear Response

Insertion Gain

Visible speech mapping

RECD (Coupler difference)

Current Protocol is listed in the lower left-hand corner.

Upon performing a test, the system automatically jumps to the next one in the test flow. A tick (✓) indicates that a curve has been measured.

Protocols can be created and adjusted in the REM440 setup (see section 2.8.2)

START ↔ STOP

START/STOP button initiates and ends all tests.

Note that after pressing *START* the text on the button will change to *STOP*.



VU-meter: The input signal can be monitored on the VU-meter. 65 dB is marked helping the clinician to find the level of normal speech

Show Example

Show Examples is ticked during the test the graph display will show illustrations of everyday sounds for matching up real life examples to the hearing loss.

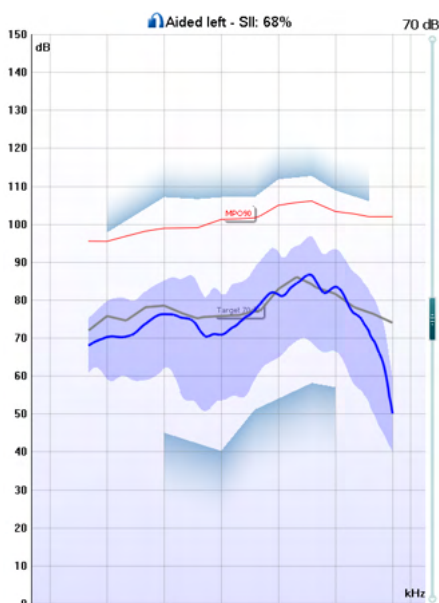

1. **The ear/coupler mode** indicates which side is being tested next to a label showing whether the test is performed in an aided or unaided ear.
2. **SII (Speech Intelligibility Index)** of the current input signal is expressed in a percentage.
3. **UCL (Uncomfortable Levels)** will be shown in shading at the top of the graph if entered in the audiogram screen.
4. **Hearing thresholds** converted to SPL is indicated in shading at the bottom. Together with the UCL they form a **dynamic range** view.
5. **Hearing aid response** is indicated in blue/red (corresponding to the ear tested). This is compared to the chosen fitting target indicated in grey.
6. **Display peaks and valleys/Percentile analysis** is indicated as a blue/red shaded area (corresponding to the ear tested) surrounding the hearing aid response (see more information in section 2.14.2 and 2.14.1)

Fitting prescription

Name

Age

Client type

Instrument

Vent size

Transducer

Coupler type

Show/Hide fitting prescription and test information: Using the arrow to the right you can choose to show or hide fitting prescription details and test information.

The dropdowns allow for changing details during the measurement.

Choose a fitting prescription from a selection of Berger, DSL *m[i/o]*, Half Gain, NAL-NL1, NAL-NL2, NAL-R, NAL-RP, POGO1, POGO2, and Third Gain.

Based on the selected fitting prescription (and the audiogram) targets are calculated and shown in Visible Speech Mapping screen **if NO audiogram has been entered into the audiogram screen no targets will be displayed.**

Note: fitting prescription settings (such as *Age* and *Client type*) will differ depending on what fitting prescription is selected.

Recorded method	Sweep 1/6 Oct.
Input Level	70 dB SPL
Stimulus	Warble Tone
Measured in	Real Ear
Curve type	Measured

Measurement details of the selected curve are displayed as a table on the right-hand side of the screen.



Curve comment
This is a test comment...

70 dB
 70 dB
 70 dB

Curve comment for each curve can be typed into the comment section on the right-hand side. Select a curve using the curve tag boxes under Curve display options and write a comment in the comment section. The comment will then appear in the comment section whenever the curve is selected.

70 dB
 70 dB

Curve display options are found in the lower right-hand corner. If you have measured more VSPM curves, they will be listed by their input level. Tick the ones that are to be displayed on the graph.

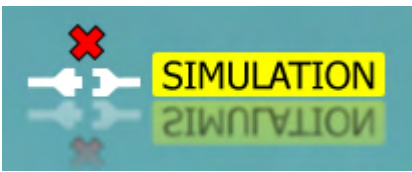

Hardware indication picture indicates whether the hardware is connected. When opening the Suite, the system will automatically search for the hardware. If it does not detect the hardware it will continue to run in simulation mode.





2.13 Verification with visible speech mapping

2.13.1 Considerations before you begin

Visible Speech Mapping can be run side by side with the relevant fitting software. After fitting the hearing aid, Visible Speech Mapping can be used to verify if the client's speech area is amplified sufficiently using these stimuli: ISTS, Male Speech, or Female Speech.

Visible Speech Mapping can be used as a verification measure and does therefore not necessarily need to be performed together with an Insertion Gain measurement. Visible Speech Mapping provides a precise measure of the SPL at the ear drum matched up to a fitting target selected by the clinician.

The following description introduces the clinical use of Visible Speech Mapping. The system can be used in all sorts of ways. Clients have very different needs, and this section demonstrates the options offered by the system.

2.13.2 Visible speech mapping (in ear mode)

- 1) Open the REM440 module.
- 2) Select a test protocol that includes Visible Speech Mapping in the **List of Protocols**.

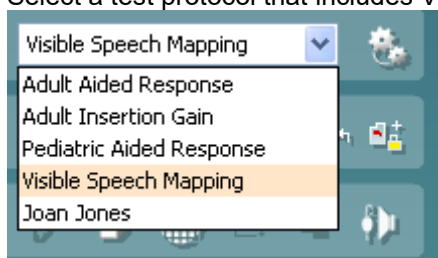

- 3) Explain the procedure to the client.
- 4) Perform otoscopic examination.
- 5) Mount the probe tube on the in-situ headset and place it on the client who should be seated ½-1 meters from the speaker.
Ensure that the probe tubes are calibrated before placing them in the ear canal (see section 2.6.2 about tube calibration).
- 6) Carefully insert the hearing aid without moving the probe tube. Ensure that the instruments are switched on.
- 7) If fitting an open hearing aid solution, perform **Calibrate for open fit** (see section 2.6.4).
- 8) Click on the **Visible Speech Mapping** button if it is not already marked automatically.
Note: A right click on Visible Speech Mapping button allows you to enter the *Settings* menu or *Change color* of the curve.

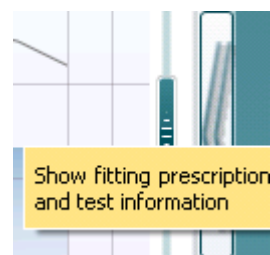



- 9) Check that the information about client, fitting prescription and hearing aid to the right are correct by pressing **Show fitting prescription and test information**.

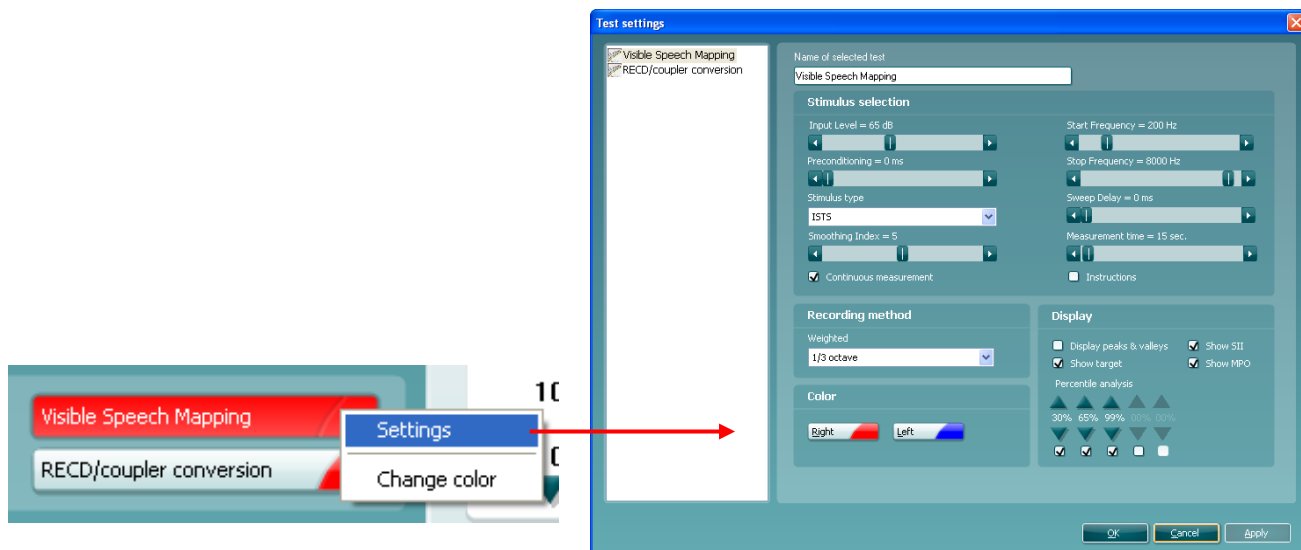

- 10) Ensure that the correct **Ear** is selected

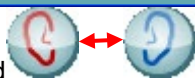

If you wish to measure on both ears right click on the ear icon

- 11) Choose the preferred **Stimulus** in the corresponding dropdown list . Male Speech, Female, Speech, and ISTS are recommended. Note the option to use *Live Voice*.

If you have done Calibrate for open fit *only the signals used for this calibration are available in the stimulus selection dropdown* (see section 2.6.4).



- 12) Select input level using the Input level slider
- 13) Click **START** and the Visible Speech Mapping will be performed. Ensure that the hearing aids are switched on and that the room is quiet while the curve is obtained.
- 14) Verify and fine-tune to your chosen fitting prescription; DSL mi/o or NAL-NL1/NAL-NL2. Use **On Top Mode** to compare to the hearing aid manufacturer's software



2.13.3 Visible speech mapping (in coupler mode/test box mode)

- 1) Open the REM440 module.
- 2) Select a test protocol that includes Visible Speech Mapping and RECD in the **List of Protocols**.

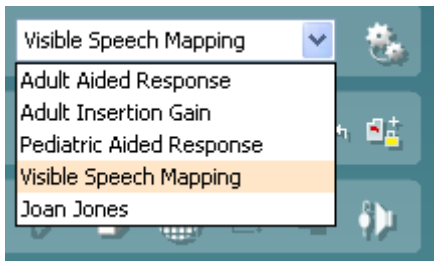

- 3) Explain the procedure to the client/relatives.
- 4) Perform otoscopic examination.
- 5) Perform the RECD with the client's own ear mould or the SPL probe (see section 2.7.4). Also note the option to select a predicted RECD (see section 2.7.4.4).
- 6) Place the hearing aid in the test box as shown below and ensure that it is switched on. It is important that the reference microphone is placed in the same acoustical point as the microphone in the hearing aid. The placement may therefore differ a little depending on the hearing aid you are testing.



- 7) Click on the **Visible Speech Mapping** button if it is not already marked automatically.

Note: A right click on Visible Speech Mapping button allows you to enter the *Settings* menu or *Change color* of the curve.

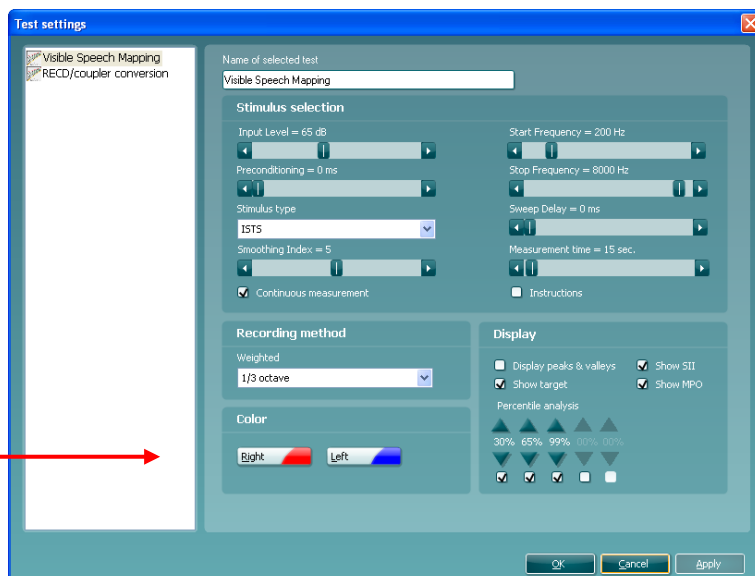

- 8) Check that the information about client, fitting prescription and hearing aid to the right are correct by pressing **Show fitting prescription and test information**.

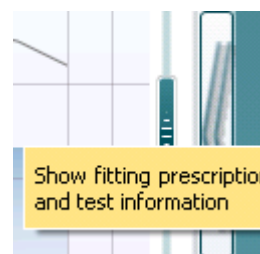

- 9) Ensure that the correct **Ear** is selected. Note that *Both ears* are not an option for coupler mode.

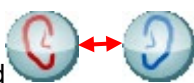

- 10) Choose the preferred **Stimulus** in the corresponding dropdown list. Male Speech, Female, Speech, and ISTS are recommended. Note the option to use *Live Voice*. In this case the test box lid should be left open.



- 11) Select input level using the Input level slider.
- 12) Click **START** and the Visible Speech Mapping will be performed. Ensure that the hearing aids are switched on and that the room is quiet while the curve is obtained.
- 13) Verify and fine-tune to your chosen fitting prescription. DSL mi/o or NAL-NL1/NAL-NL2. Use **On top mode** to compare to the hearing aid manufacturers' software



2.14 Visual tools for counseling and verification

2.14.1 Percentile analysis

The Percentile Analysis can be added in the REM440 setup.

The Percentile Analysis is implemented according to the IEC 60118-15 standard.

By default, the 30th, 65th, and 99th percentile is selected. These percentiles are calculated based on an FFT analysis of 100 measurements.

The 30th percentile (indicated in blue shading) is the sound pressure level below which 30% of the measured levels are found for each frequency. The remaining 70% of the measured sound pressure levels are higher. The 30th percentile thereby represents the lower valleys or the soft components of the speech signal. This helps you ensure that even the soft valleys are above thresholds.

The 99th percentile (indicated in green shading) is the sound pressure level below which 99% of the measured levels are found for each frequency. The 99th percentile may be interpreted as a peak indicator which helps to ensure that no peaks come too close to the MPO and/or UCL's. In other words, the 99th percentile represents the loud components of the speech signal.

Together the 30th and 99th percentile provides an “area of audibility”. The 65th percentile serves as a borderline between the 30th and 99th percentiles and is visually represented at the point where the blue and green areas meet. The 65th percentile represents the median whereas the measurement is the average of the FFT analysis of the 100 measurements.

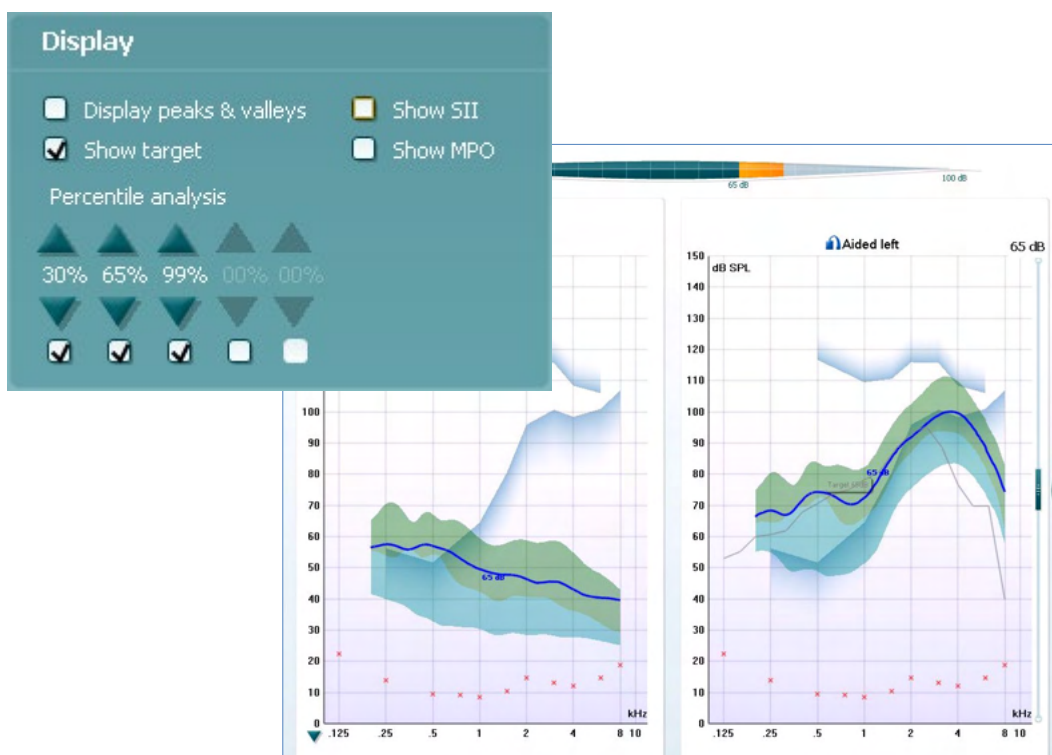

Picture note: On this illustration the percentile analysis reveals important information about the hearing aid fitting. At 3-4 kHz the peaks of the signal (the 99th percentile) are too close to the UCL. However, we also see that even though we cannot fit above thresholds the client is still getting some speech information in this frequency area since the 99th percentile is above thresholds. In the low frequency area, we can see that even though the curve is above threshold, and we match target, the lower valleys (30th percentile) are not above thresholds and the client is thereby missing information.



2.14.2 Display peaks and valleys

Display peaks and valleys can be added in the REM440 setup (see section 2.14.2)

When *Display peaks and valleys* is ticked you will have the view illustrated below. The peaks and valleys are shaped according to the LTASS and are the same as the 30th and 99th percentile in the Percentile Analysis described in section 2.14.1.

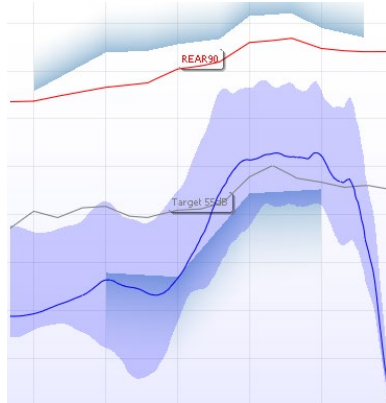

2.14.3 Show examples

Tick **Show Examples** and show the speech area together with sound examples from real life like a dog barking or the wind rustling leaves.

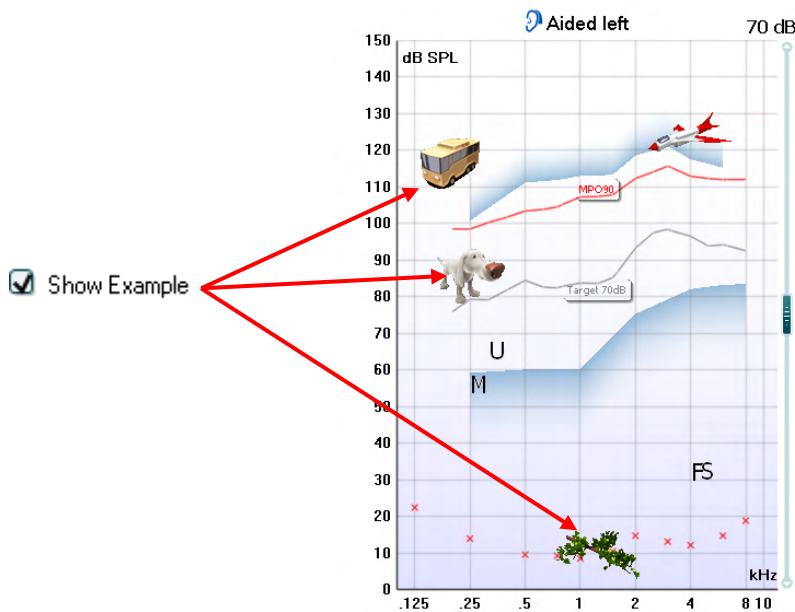



2.14.4 Speech intelligibility index

As a supporting feature the SII (Speech Intelligibility Index) indicates improved audibility expressed in a percent on the aided display.

SII is a method for computing a physical measure of the intelligibility of speech. The method is based on results of the speech perception tests in each group of talkers and listeners. The SII is calculated from acoustical measurements of speech and noise, considering the level of the distortion factor at standard speech level. (www.sii.to)

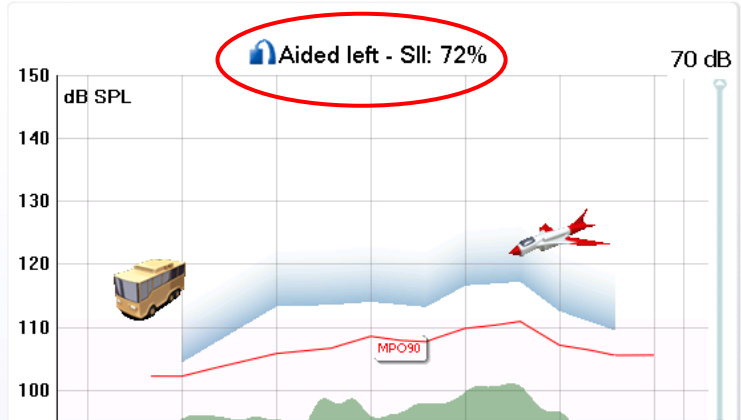

2.14.5 Speech spectrum

Add a **Speech spectrum** view by right clicking on the graph. This is useful when explaining the importance of speech audibility and/or language development.

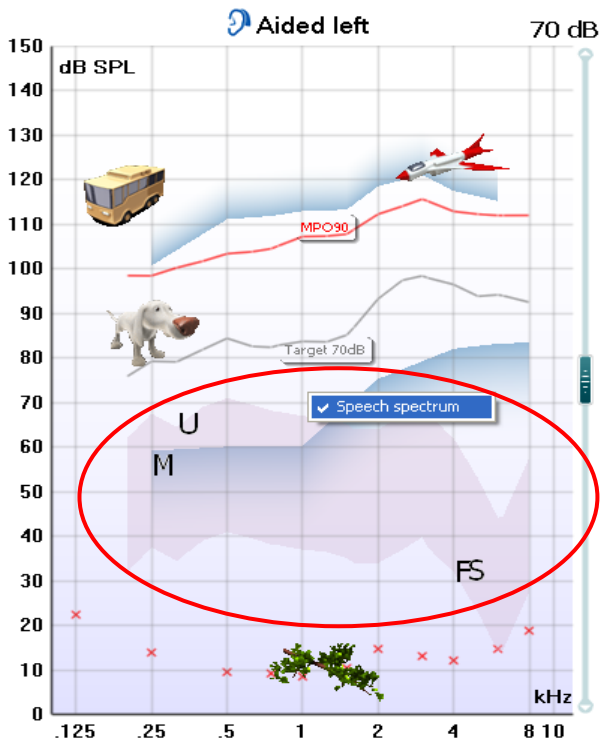



2.14.6 Dynamic range view

The hearing thresholds converted to SPL and the UCLs provide a dynamic range view. This provides the option to show that speech sounds are above thresholds and are within the area where the client can hear (but without being uncomfortably loud).

You can demonstrate the reason why the relatives/loved ones do not need a hearing aid, but the client does by pointing out the *Normal Hearing thresholds* marked in red.

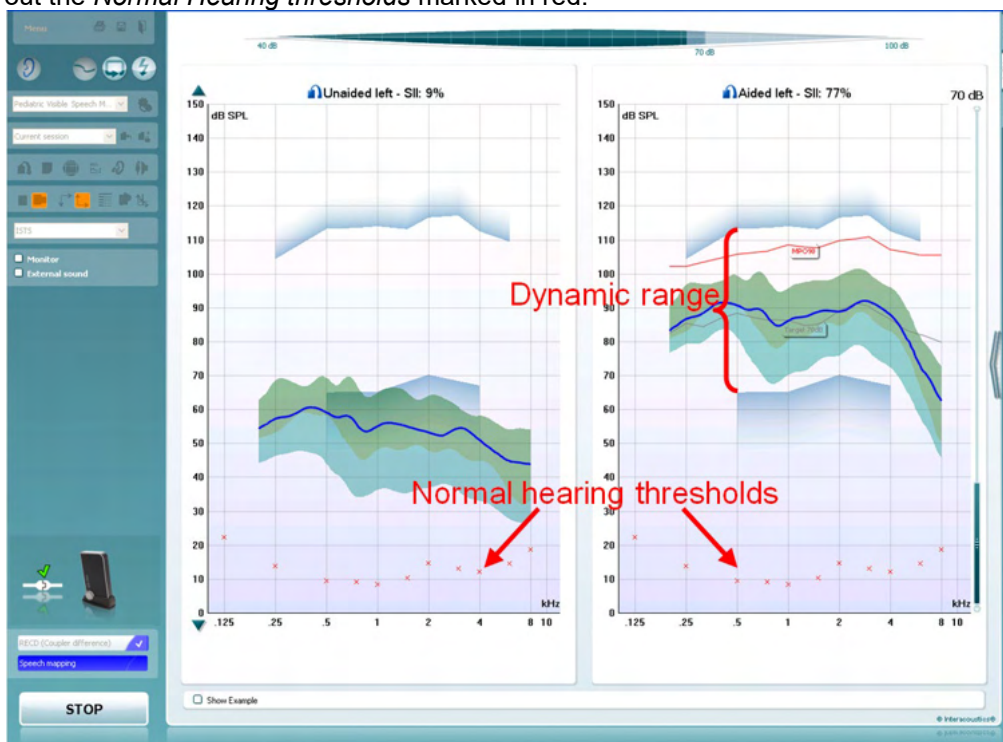

Perhaps present a loud input or speak loudly to visualise the compression of sounds in the hearing aid and point out that peaks in amplified sound never go beyond the MPO and UCLs.



2.14.7 Aided versus unaided

If the client/relatives have no experience with hearing aids, it may be a good idea to focus on the difference between the aided and unaided. This helps to demonstrate the hearing aid benefit effect and the importance of wearing instruments. If fitting children, this also gives a good basis for discussing language development. Note that the unaided graph shows the dB SPL at the reference microphone and the aided graph shows the SPL at the ear drum.

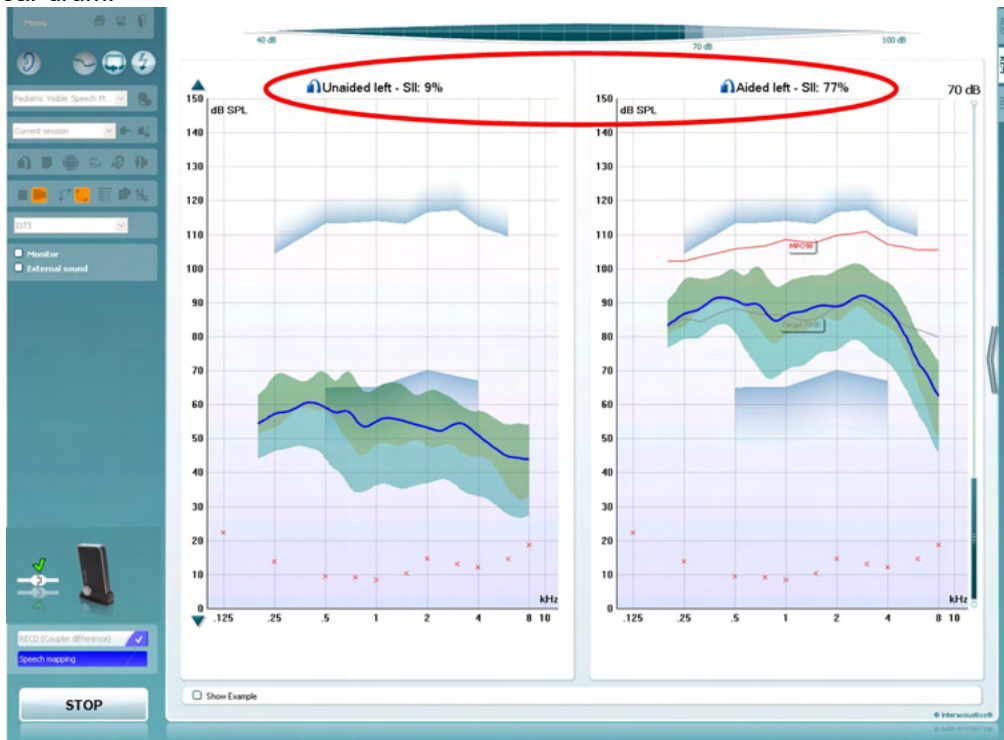



2.15 Visible speech mapping settings

Visible Speech Mapping with individual settings can be added to a test protocol the same way as other REM tests (see section 2.8.2)

- 1) Enter the REM440 setup (**Menu/Setup/REM440 setup**) and add Visible Speech Mapping to the test protocol.

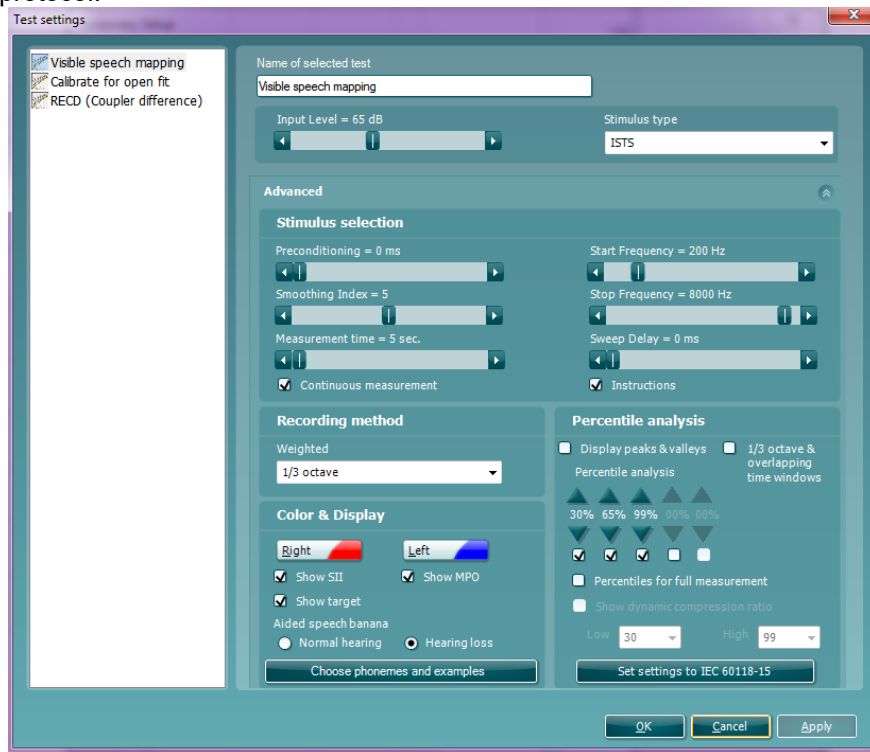

- 2) Ensure that **Visible Speech Mapping** is marked in the left-hand side of the screen. The name of the test will then appear in the *Name of selected test* section. Note the option to write a new name for the test in this section (e.g., “Visible Speech Mapping 65 dB”)

3) Stimulus selection

- **Input Level:** Set the input level using the slider.
- **Preconditioning:** This is relevant when using broadband signals such as ISTS (see section 2.6.10.1 for details). Select a time using the slider.
- **Stimulus type:** Select a stimulus using the dropdown list. Note that Live Voice is also an option. However, this is not a calibrated test signal and should therefore only be used for counselling purposes.
- **Smoothing Index:** You have the option to smooth the measured curve using the slider (see section 2.6.11 for details). The higher the index number selected the more smoothing is applied.
- **Continuous:** This check box allows you to make the measurement ongoing rather than a single sweep. This may, however, also be done in the front screen using the continuous button:



When continuous is ticked, the stimulus and recording will continue until you press the STOP button. This can be practical for example when using Live Voice.

- **Start Frequency and Stop Frequency:** Select the preferred frequencies using the sliders. These may for example be set so that they correspond with the hearing aid gain handles (e.g., if the hearing aid goes up to 8000 Hz there is no reason to measure beyond this frequency).
- **Sweep delays:** This is relevant if *Continuous measurement* is selected for Pure Tone or Warble Tone. In this case sweep delays (in milliseconds) may be entered between the individual sweeps (see section 2.6.10.2 for details).



- **Measurement time** (in seconds): Duration for the measurement can be set using the slider. This is only relevant for broad band signals. Several seconds can freely be selected between 1 and 1200. By default, the measurement time is the same for all signals.
- **Instructions:** This allows for adding picture instructions. If the box is ticked an instruction box explaining how to perform the measurement will appear upon pressing **START**.

4) **Display:**

- **Display Peaks and Valleys:** This is relevant when using a broad band signal. When ticking the check box, the REM440 will show the measured maximum and minimum area in the speech spectrum over time (5 seconds) on screen. The measurement is independent of the selected measurement time.
- **1/3 octave and overlapping time window:** For speech-like signals, the signal is converted into an FFT and then sampled. The clock frequency of the Callisto™ is 44100 Hz and we do 1024 samples per second. This means that the time for each sample is 23 ms.
- **Percentiles for full measurement:** activate this box if you want to see the intensity components in different shaded percentile sections – these are customisable and will show the output as a shaded range on the graph.
- **Show dynamic compression ratio:** Enabling this feature will display the dynamic compression ratios when the 1/3 octave and overlapping time windows option is enabled.
- **Set settings to IEC 60118-15:** use this button to set the measurement settings according to the IEC 60118-15 standard³³ this will amend the settings mentioned above to meet this configuration description.
- **Show target:** This will add the fitting target from the screen or REM440 setup (see section 2.8.4) by default.
- **Show SII:** This will add the Speech Intelligibility Index to the graph (see section 2.14.4)
- **Show MPO:** This will remove the MPO when using the DSL mi/o fitting prescription in Response view.
- **Percentile analysis:** Here percentiles can be selected for the percentile analysis (see section 2.14.1). The recommended percentiles are 30th, 65th and 99th. When *Display peaks and valleys* is ticked it is NOT possible to set percentiles under Percentile analysis.

5) **Recording method:**

- **Resolution** (of frequency): Select the preferred resolution in the dropdown. The higher the resolution the slower the measurement.

Keep in mind that 1/3 is what is used in many hearing aid manufacturers software. If the curve is to be compared to this, you may consider choosing this resolution. Also note that when using a broad band signal the dropdown list will be greyed out and automatically choose FFT. This makes the distance between frequency bins 43 Hz which ensures precision in the measurement.

³³ For detailed information, please refer to the IEC 60118-15 standard.



6) **Color:**

- Select a color for the *Right* and *Left* curve.
Press each of the buttons to have the custom color selection below. Choose the desired color by clicking on it and press *OK*.

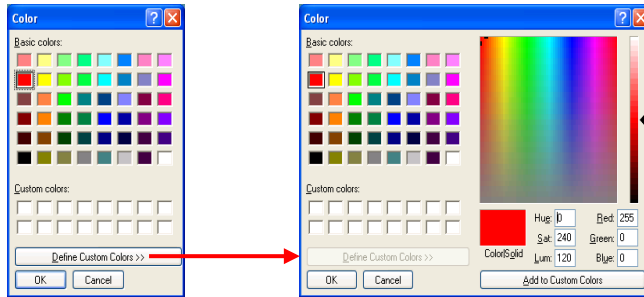

Note the option to *Define Custom Colors* and get a more extensive selection. When having found the exact color, press *Add to Custom Colors*.



2.16 FAQ

Question:

After I accidentally disconnected the USB my system behaves strangely – what could be the cause?

Answer:

If the USB is disconnected during testing the software suite should be restarted. Otherwise, the connection may be affected, and testing may be compromised.

Question:

There is no target on my screen. What could be the reason?

Answer:

1. Please check that you have typed in or selected an audiogram in the AUD tab. If no audiogram is present the system cannot calculate a target
2. Please check that the transducer you have selected in the Fitting prescription options corresponds to the transducer used for the selected audiogram
3. For NAL-NL1/NAL-NL2 please make sure that all important frequencies are included in the audiogram (e.g., 500, 1000, 2000, and 4000 Hz). This also corresponds for Bone conduction targets where you need the BC values.

Fitting prescription

Name	NAL-NL2
Age	Adult
Gender	Unknown
User level	New user
Instrument	Behind the ear
Vent size	Occluded
Transducer	Head phone
Curve type	Head phone
Stimulus	Insert
Curve comment	Insert + mold
	Sound field 0 deg.
	Sound field 45 d...

Question:

What is the broad band sound before some measurements, and can it be switched off?

Answer:

The broad band noise that you hear before a measurement starts is presented ONLY when using broad band test stimuli or wave files. This type signals must thus be preceded by this preconditioning and calibration, and it cannot be switched off. During the calibration/preconditioning the distance between the loudspeaker and the reference microphone on the in-situ headset is measured. This ensures a precise measurement. If this calibration does not take place, you cannot be sure if the correct input level enters the ear canal and as a result you are at risk of measuring erroneous curve.

Question:

I have seen that when you perform REAR in Callisto™ REM440 using DSL mi/o fitting prescription the REAR target changes with the choice of stimulus selection (much lower target with ISTS compared to REAR target with warble or pure tone). However, REIG target remains the same whatever stimulus had been chosen. Would you please send me some information/comment about that?

Answer:

The REIG (pure hearing aid gain) is the same regardless of what stimulus you use. This is because the REIG is a calculation and not a measurement (REAR – REUR = REIG). The result of the calculation will be the same regardless of whether it is REAR (ISTS) – REUR (ISTS) or REAR (Warble) – REUR (Warble). Even though the REAR (ISTS) and REAR (Warble) are very different, this difference is also reflected in the REUR (ISTS) and REUR (Warble). Thus, the result is the same.



Question:

What kind of stimulus does Interacoustics recommend being used and in different situations?

Answer:

Choosing the correct stimuli for the purpose is extremely important as it is the basis of a good measurement with a valid result. Digital hearing aids automatically adjust the amplification depending on the input. This capacity, however, cannot be reflected in a real-ear measurement unless a realistic and dynamic test stimulus like speech is used (Fabry 2004).

Using Tone Stimuli

For many years pure tones (sinusoids)/warble tones were the primary signals used for real-ear as well as coupler verification. Tone signals are “simple” signals and only one frequency is presented at the time. Therefore, real-ear measurements performed with tone signals do not reflect advanced signal processing where frequencies interact (Kuk & Ludvigsen 2003).

Using Speech Stimuli/ISTS

Speech is likely to be most important signal to the hearing aid user in his or her daily life. Therefore, if you wish to verify if speech sounds are audible there is no better stimulus than speech. When using a speech signal the hearing aid will also stand its test since speech has the challenge of changing quickly in amplitude, frequency, and phase.

ISTS (International Speech Test Signal) is an internationally recognized test signal. It was created based on the need for a standard test stimulus that included all the relevant properties of speech and allowed for reproducible measurement conditions. It is created from natural recordings of speech which is non-intelligible due to remixing and segmentation. The signal reflects a female speaker for six different mother tongues (American English, Arabic, Chinese, French, German, and Spanish) reading “The north wind and the sun”.

The ISTS is shaped according to the LTASS (Long Term Average Speech Spectrum) standards (Holube et al. 2007).

Using Composite Signals/ICRA

Artificial signals without significant variation in intensity and frequency can also be used to test hearing aids in the frequencies of speech. These are called speech spectrum shaped composite signals and have the same long-term spectral characteristics as speech.

The advantages in such signals are that you can test many frequencies in a short time and that interactions among frequencies can be tested.

The ICRA signals (International Collegium of Rehabilitative Audiology) are examples of composite signals. They are a group of test signals developed by the HACTES group (Hearing Aid Clinical Test Environment Standardisation) to be able to do reliable measurements on non-linear digital hearing aids. They represent several speech weighted noise signals composed with spectral and temporal characteristics like those that are found in speech signals and babble noise. (www.icra.nu).

What Stimulus to choose?

Which stimulus to select depends on your focus and the individual patient.

If for example seeing a patient who complains about not being able to hear his wife, you may want to try the ISTS.

If the patient is having trouble when more than one person is speaking, the ICRA 6pbl (or one of the other signals with multiple people speaking) may be selected.

If you wish to look at the effects of a noise reduction, a noise signal such as Pink Noise may be the appropriate choice.

Note that your choice has an impact on your result as illustrated below:



References:

Fabry D. (2004) Real Ear Measurements and Digital Hearing Aids: Realities, Myths, and Measurement Techniques. Phonak Focus no. 32. (www.phonak.com)

Kuk, F & Ludvigsen, C. (2003) Changing with Times: Choice of Stimuli for Hearing Aid Verification. Hearing Review, August 2003.

Holube, I & EHIMA-ISMADHA working group (2006) Short description of the International Speech Test Signal (ISTS). Centre of Competence HörTech and Institute of Hearing Technology and Audiology, Oldenburg, Germany

http://www.icra.nu/Prod_Noise.html



Question:

When I do the REUR with an ICRA or ISTS I get a flat curve:

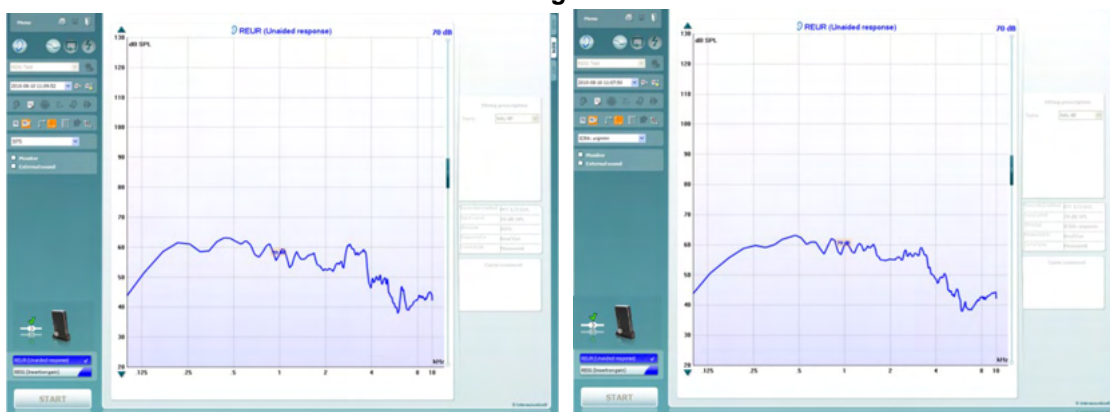

When I do the REUR with a warble tone I get, what I think is a correct curve:

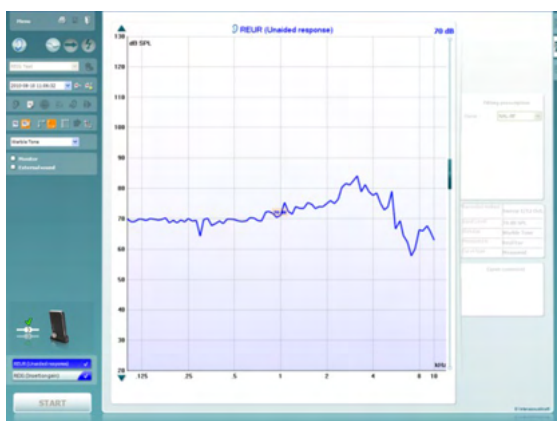

What is the reason for this difference?

Answer:

With response measurements you are measuring the ear canal + the signal you are using. This means that you have two components affecting the result.

When using **pure tones**, the signal has the same energy at each frequency. Then you get an REUR the shape like the lower image above. However, your curves above are correct as well. When you are using a **broad band signal** the energy is not the same at each frequency and this affects the response measure! This can be seen from your own examples above.

The REUG does not consider the test signal. Therefore, you don't see a similar difference for the REUG

Question:

When I do the REUG I have to do the REAG and then I don't see the REIG. That means that I'm not going to use this setup. I can't choose the REIG without the REUR according to the program.

Answer:

In the Callisto™ you don't have to do the REAG/REAR to see the REIG. When you have done the REUR the system automatically knows that you need the REAR to calculate the REIG. When you have measured the REUR and go to REIG the system will perform the REAR in the background (without showing it on screen), to calculate the REIG.

NOTE: The Callisto™ Suite demands that you do the REUR to calculate the REIG. The REIG can only be selected as part of the protocol if REUR is also a part of it.



Question:

How are the Monitor/External sound features used?

Monitor

Answer:

Monitor: If you wish to listen to the amplified stimulus through a monitor.

1. Connect a monitor speaker/headset to the monitor output on the hardware.
2. Tick the Monitor check box.
3. Use the slider to turn the sound level up and down.

Note that the sound from the monitor may be very soft (compared to the audiometry monitoring). It is louder for audiometry because the audiometric equipment is producing the signal that is monitored. In REM440 the hearing instrument produces the monitored signal meaning that it cannot be controlled by the equipment. However, if you have an active speaker, it will be louder.

Question:

I did the calibration for open fit with the ISTS signal and the measurement. The Callisto™ only did the calibration sound followed by a short stimulus presentation. Furthermore, the curve looks strange. Is this how it should be?

Answer:

Yes, this is perfectly normal. The system only needs the calibration signal to consider the open fit. It does not matter what is shown on the screen. The measurement is still correct.

Question:

In Visible Speech Mapping what is the purpose of percentile analysis?

Answer:

The Percentile Analysis implemented according to the IEC 60118-15 standard.

By default, the 30th, 65th, and 99th percentile are selected. These percentiles are calculated based on an FFT analysis of 100 measurements.

The 30th percentile (indicated in blue shading) is the sound pressure level below which 30% of the measured levels are found for each frequency. The remaining 70% of the measured sound pressure levels are higher. The 30th percentile thereby represents the lower valleys or the soft components of the speech signal. This helps you ensure that even the soft valleys are above thresholds.

The 99th percentile (indicated in green shading) is the sound pressure level below which 99% of the measured levels are found for each frequency. The 99th percentile may be interpreted as a peak indicator which helps to ensure that no peaks come too close to MPO and UCL. In other words, the 99th percentile represents the loud components of the speech signal.

Together the 30th and 99th percentile provides an “area of audibility”. The 65th percentile serves as a borderline between the 30th and 99th percentiles and is visually represented at the point where the blue and green areas meet. The 65th percentile represents the median whereas the measurement is the average of the FFT analysis of the 100 measurements.

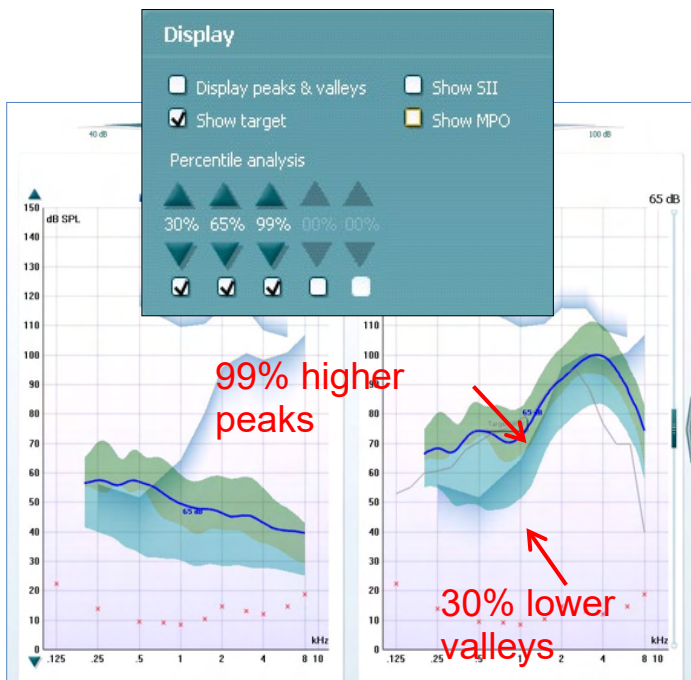

Picture note: On this illustration the percentile analysis reveals important information about the hearing aid fitting. At 3-4 kHz the peaks of the signal (the 99th percentile) are too close to the UCL. However, we also see that even though we cannot fit above thresholds the patient is still getting some speech information in this frequency area since the 99th percentile is above thresholds. In the low frequency area, we can see that even though the curve is above threshold, and we match target, the lower valleys (30th percentile) are not above thresholds and the patient is thereby missing information.



2.17 Appendix 1

2.18 The REM440 test signal characteristics

Pure Tone frequency accuracy is $\pm 1\%$. Crest factor is 3 dB.

Warble Tone frequency accuracy is $\pm 1\%$, warble frequency 0→100 Hz and intensity 0→10%, sine wave frequency modulation. Crest factor is 3 dB.

Random Noise is a noise with a linear spectrum measured with an FFT or a 3 dB drop per octave measured with a 1/3 octave filter.

Pseudo random noise. Is a semi-broad-band noise produced from random noise weighted with a 2nd order 200 Hz high pass filter and a 1st order 900 Hz low pass filter as described in the ANSI S3.42 -1992 standard. Crest factor is 10 dB.

Chirp. Is a linear frequency sweep from 100 to 10 kHz in 23 mS = one FFT measuring. The amplitude is constant during the sweep. Crest factor = 3 dB.

Band limited white noise is a random noise signal band limited by 12 kHz 2. order low pass filter. Crest factor is 9 dB.

ISTS is “for analyzing the processing of speech by a hearing aid, a standard test signal is necessary which allows for reproducible measurement conditions, and which features all or most relevant properties of natural speech. Those properties are e.g., the modulation spectrum and the fundamental frequency as well as its harmonics. Existing artificial signals fulfill these requirements inadequately and recordings from natural speakers represent only one language and are therefore not internationally applicable. Therefore, the European Hearing Instrument Manufacturing Association (EHIMA) has set up the ISMADHA working group and has initiated this project resulting in an International Speech Test Signal (ISTS). The ISTS is based on natural recordings but is largely non-intelligible because of segmentation and remixing. The intention is to include this test signal with a new measurement method for a new hearing aid standard” (Holube et al. 2006).

PinkNoise is a noise with a linear spectrum measured with a 1/3 octave filter or a 3 dB rise per octave measured with an FFT.

ICRA noise:

ICRA: urgnmn

Unmodulated random Gaussian noise - Male weighted - Normal effort - Level Ref. Crest factor = 13 dB.

ICRA: urgnmr

Unmodulated random Gaussian noise - Male weighted - Raised effort - Level Ref+5.7dB. Crest factor = 14 dB.

ICRA: urgnml

Unmodulated random Gaussian noise - Male weighted - Loud effort - Level Ref+12.1 dB. Crest factor = 14 dB.

ICRA: 3bsmfn

3 Band speech modulated noise (3bSMN) - Female weighted - Normal effort - Level Ref. Crest factor = 27 dB.

ICRA: 3bsmnmn

3 Band speech modulated noise (3bSMN) - Male weighted - Normal effort - Level Ref. Crest factor = 27 dB.

ICRA: 2pb1f1mn

2 persons babble, 1female 3bSMN + 1 male 2bSMN - Idealized - Normal effort - Level Ref + 3dB. Crest factor = 24 dB.

ICRA: 6pbn



6 persons babble, 1f+1m+2f(-6db)+2m(-6dB), all 3bSMN - Idealized - Normal effort - Level Ref + 4.7dB. Crest factor = 23 dB.

ICRA: 6pbr

6 persons babble, 1f+1m+2f(-6db)+2m(-6dB), all 3bSMN - Idealized - Raised effort - Level Ref + 10.7dB. Crest factor = 24 dB.

Speech Dialog Crest factor = 24 dB.

Speech Female Crest factor = 20 dB.

Speech Male Crest factor = 25 dB.

Sound File this Crest factor is not known.

2.18.1 Signal analysis characteristics

The following table summarises the signal analysis characteristics of the Callisto system.

Broadband analysis	
Measurement bandwidth:	43Hz
Integration time:	1 – 1200 sec.

Spectrum analysis, sweep filtered	
Filter bandwidth:	1/3 octave
Skirt slope:	12dB pr. Octave

Spectrum analysis, digital means	
Sampling rate	44100Hz
Digital resolution:	1024 FFT (43Hz)
Average time:	1 – 1200 sec.
Analyze bandwidth:	100 – 10000Hz
Block length:	23ms
Window type:	Blackman Harris
Window overlap:	None
Method:	Amplitude spectrum
Total frequency range:	50 – 20000Hz



2.19 REM PC shortcuts

Quick Keys	REM/HIT
Tab	Next test
Shift + Tab	Previous test
Shift + Mouse scroll or Shift + Arrow up/down	Curve smoothing increase/decrease
Mouse Scroll	Offset Y axis
PgUp/PgDn	Offset Y axis
Arrow up/down	Change input level
Control + R	Right ear
Control + L	Left ear
Control + B	Both ears
F2	Start/Stop
F3	Toggle between right and left
F5	Combined or individual curve view
F6	Single or repeated measurement
F7	Manual single frequency
F8	Advanced or simple view
F9	Normal or reversed coordinate system
F10	Jump to current session
F11	Add overlay and jump to current session
F12	Freeze curve



2.20 REM software - technical specifications

Medical CE-mark:	The CE-mark indicates that Interacoustics A/S meets the requirements of Annex II of the Medical Device Directive 93/42/EEC. Approval of the quality system is made by TÜV – identification no. 0123.	
Real Ear Measurement standards	IEC 61669, ANSI S3.46.	
Stimuli	Live voice Warble tone Pure tone Speech noise Random noise Pseudo Random noise Pink noise Chirp White noise band limited ICRA	Real speech ISTS Narrow band noise /SS/ /SH/ IFFM IF noise Real life sounds Custom sound files (automatic calibration available)
Frequency range	100Hz – 10kHz	
Frequency accuracy	< ± 1 %	
Distortion	< 2%	
Intensity range	40 – 100 dB	
Intensity accuracy	< ± 1.5 %	
Measurement Intensity Range	Probe microphone: 40-140 dB SPL ± 2 dB Reference microphone: 40 – 100 dB ± 2 dB	
Frequency Resolution:	1/3, 1/6, 1/12, 1/24 octave or 1024-point FFT.	
Cross talk	Cross talk in the probe and probe tube will alter the obtained results with less than 1 dB at all frequencies.	
Narrow band noise	5/12 Octave filtered	
Available tests:	REUR REIG RECD REAR REAG REOR	REOG REUG Input/output FM Transparency Directionality Visible speech mapping
Compatible Software:	Noah 4, OtoAccess® and XML compatible	



3 HIT440

HIT testing can be performed with the Callisto™ through additional purchase of the HIT license and the TBS10 test box.

3.1 HIT440 quick guide

- 1) Open **Noah** and select the patient you want to work with:

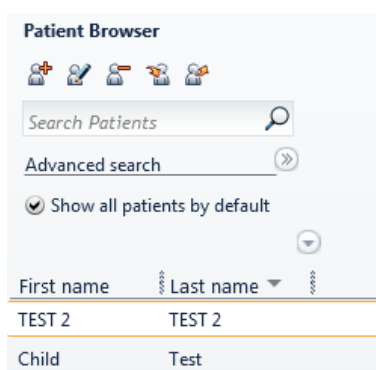

- 2) Select the Callisto™ module from the Noah Module menu

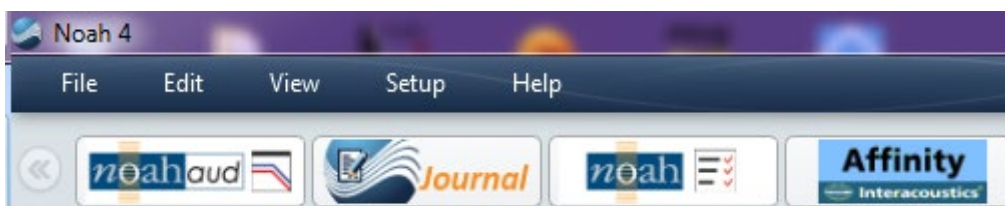

- 3) Select the HIT Icon in the upper right corner of the screen:



IMPORTANT NOTE: The hearing instrument needs to be in FULL ON GAIN MODE/TEST MODE to compare the results to the hearing aid manufacturers' technical data sheets. Each hearing aid manufacturer has a different way of accessing this Test Mode. Please check with the hearing aid manufacturers for instructions on how to program the hearing aid into TEST MODE.



4) Position the Hearing Aid in the test box:

BTE: Connect the 2 cc coupler to the BTE adaptor. Place the coupler tube pointing straight forward, and the microphone at the cross.



ITE: Connect the ITE adaptor to the 2 cc coupler and attach the hearing aid using blue putty. Place coupler at the back with hearing aid facing forward with the microphone at the cross. (For multiple microphones, rotate hearing aid to get equal horizontal positioning of the mic inputs).



Open fit/Receiver in the ear: Connect the ITE adaptor to the 2 cc coupler. Remove the tip/dome from the hearing instrument and attach it to the ITE adaptor using putty (blutack). Place the coupler tube pointing straight forward, and the microphone at the cross.





- 5) Position the reference microphone next to the hearing aid microphone as shown on the illustrations above.

Select the desired test protocol in the **List of Protocols** 

- 6) Select **Test Ear** 

- 7) Select **START** 

- 8) Please wait for all tests of the selected protocol to be performed:

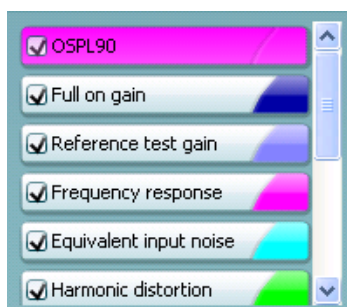

Save by clicking “Save” icon 

3.2 About HIT440

The HIT440 is a straightforward Hearing Instrument Testing system suited for all types of hearing aids. The system includes ANSI or IEC standards which can be selected from the main screen. This allows for easy technical measures and comparison to the hearing aid manufacturer’s data sheets.

The HIT440 also offers testing of advanced algorithms such as directionality and contains a wide range of test stimuli designed for non-linear hearing aids including the ISTS and ICRA. These allow you to have an impression of the algorithms functioning together during quick changes in amplitude, frequency, and phase.

HIT440 is flexible and permits the creation of an unlimited number of personalized test protocols for different purposes and/or for different professionals working in the same facility. This enables each individual professional to setup the module exactly the way they wish using the specific tests, stimuli, and settings they prefer. These personal test protocols can swiftly and easily be chosen at any time accommodating the need for speed in a busy clinic.

Furthermore, the HIT440 allows you to make individual print layouts, keep reports electronically, and compare actual curves to previous sessions. These numerous setup options can be very helpful and time saving in the daily work in the clinic.



3.3 HIT 440 tests

Custom selectable tests:

- Frequency response
- Gain curve
- Harmonic distortion
- Input/output
- Intermodulation distortion
- Attack/recovery time
- Equivalent input noise
- Reference test gain
- Directionality
- Single frequency
- Delay

The IEC standard tests:

- OSPL90
- Full-on gain
- Input/output
- Attack/recovery time
- Reference test gain
- Frequency response
- Equivalent input noise
- Harmonic distortion
- Intermodulation distortion

The ANSI standard tests:

- OSPL90
- Full-on gain
- Reference test gain
- Frequency response
- Equivalent input noise
- Harmonic distortion
- Intermodulation distortion
- Input/output
- Attack/recovery time



3.4 Launching the HIT 440 software from databases

3.4.1 Launching HIT440 from Noah

If you are using HIMSA's Noah 4, the Callisto™ Suite software will install itself automatically in the menu bar on the start page, along with all the other software modules.

For further instructions about working with Noah please see the Noah operation manual

3.4.2 Launching HIT440 from OtoAccess®

For further instructions about working with OtoAccess®, please see the OtoAccess® operation manual.



3.5 The HIT440 screen



Menu provides access to File, Edit, View, Mode, Setup, and Help.

Print button allows you to will print the test results currently displayed on the screen.

Save & New Session button saves the current session in Noah or OtoAccess® and opens a new one.

Save & Exit button saves the current session in Noah or OtoAccess® and exits the Suite.

Change Ear button allows you to toggle between right and left ear. Right click on the ear icon to view *both ears*.

Toggle between single and combined screen button toggles between viewing one or multiple measurements in the same HIT graph.

Toggle between single and continuous measurement button toggles between running a single sweep or having a test signal running continuously until pressing STOP.

Freeze curve allows for taking a snapshot of a HIT curve when testing with broadband signals. In other words, the curve freezes at a particular moment while the test continues.

Note that if too many curves are frozen on the screen not all will be saved in Noah due to imposed limitations.

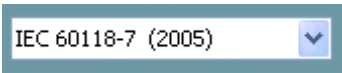

Select protocol to use from the list allows you to select a test protocol the current test session (see section 3.8 for more information about test protocols).



Temporary Setup button allows for making temporary changes to the selected test protocol. The changes will be valid for the current session only. After making the changes and returning to the main screen, the name of the test protocol will be followed by an asterisk (*).

NOTE: it will only be possible to change protocols that have been created by the user. It is not allowed to modify the protocols that are based on the IEC and ANSI standards. Therefore, Temporary Setup is disabled for ANSI and IEC protocols.



List of historical sessions accesses historical sessions for comparison purposes.



Toggle between Lock and Unlock the Selected Session freezes the current or historical session on the screen for comparison to other sessions.



Go to Current Session button brings you back to current session.



Report Editor button opens a separate window for adding notes to the current session (see section 4.2.1.1). Note that after saving the session no changes can be added to the report once the date has changed.



Single frequency button represents an optional manual test that allows for pre-setting hearing aid gain prior to HIT.

Place the hearing aid in the test box and press the single frequency button. A 1000 Hz tone will then appear allowing you to see the exact input and output of the hearing aid. Press the button again to end the test.

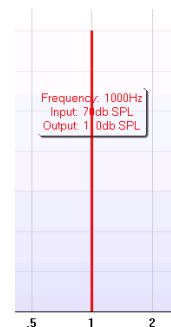

Simple view/Advanced view buttons toggle between an advanced screen view (including the test and fitting prescription information on the right-hand side) and a simpler view with a larger graph.

Advanced view



Simple view

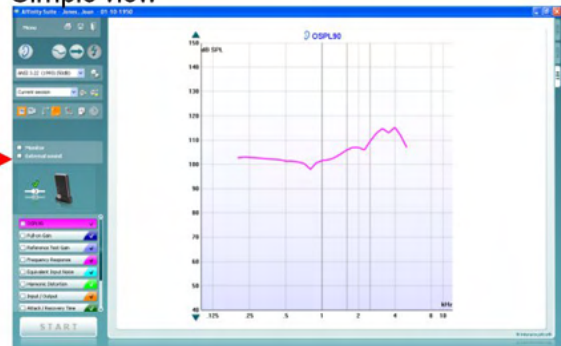



Normal and reversed coordinate system buttons enable you to toggle between reversed and normal graph.

This may be helpful for counselling purposes since the reversed curves look more like the audiogram and may therefore be easier for the patient to comprehend.



Show cursor on graph provides information about each specific measured point in the curve. The cursor is “locked” to the curve together with frequency and intensity label placed the cursor’s position as illustrated below:

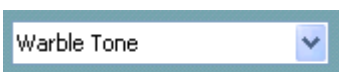
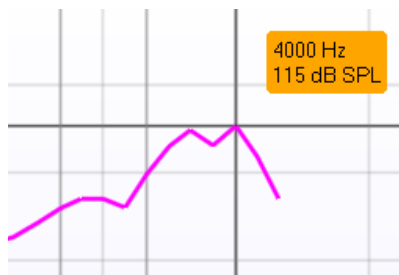

Stimulus selection: With this dropdown list the test stimulus can be chosen. The dropdown is only present for custom made test protocols. The standards (e.g., ANSI and IEC) have fixed stimuli.



Monitor: If you wish to listen to the amplified stimulus through a monitor.

1. Connect a monitor speaker the monitor output on the hardware.
2. Tick the Monitor check box.
3. Use the slider to turn the sound level up and down.

Note that the sound from the monitor may be very soft (compared to the audiometry monitoring). It is louder for audiometry because the audiometric equipment is producing the signal that is monitored. In HIT440 the hearing instrument produces the monitored signal meaning that it cannot be controlled by the equipment. However, if you have an active speaker, it will be louder.



Current Protocol is listed in the lower left-hand corner.

The indicates the test is a part of an automatic test flow (Auto Run). When pressing START all tests with the tick mark will be performed.

If you wish to perform one test only, mark it using the mouse by clicking on it. Then right click at select *Run this test*.

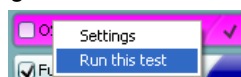

Upon performing a test, the system automatically jumps to the next one in the test flow. indicates that a curve has been measured.

Color indication shows the color selected for each curve (in the HIT440 setup, see section 3.8).

Test protocols can be created and adjusted in the HIT440 setup (see section 3.8).



Start/Stop button initiates and ends all tests.

Note that after pressing *START* the text on the button will change to *STOP*.



The Graph shows measured HIT curves. The X axis shows the frequency, and the Y axis shows the intensity of the test signal.

Measurement type is printed above the graph together with a right/left indication. In this example the OSPL90 is displayed for the left ear.

Change the input level using the slider on the right-hand side.

Scroll graph up/down on the left-hand side allows for scrolling the graph up or down ensuring that the curve is always visible in the middle of the screen.

Input level	90 dB
Frequency	
Max OSPL90 frequency	4000 Hz
Max OSPL90 level	115,25 dB
HFA frequencies	1000, 1600, 2500 Hz
HFA level	105,7 dB
Curve type	Sweep 1/6 Oct.
Stimulus	Pure Tone
Coupler type	2 cc (IEC 126)
Battery	Standard battery
Smoothing index	0

Measurement details: In this table the curve details can always be viewed. This way the professional always has an overview of what is being measured, for example, information such as Input Level, Max SPL, Curve Type, Stimulus, and Curve type.

Curve comment

Here curve comments can be added...

A Curve Comment for each curve can be typed into the comment section on the right-hand side.

Select a curve using the curve tag boxes under Curve display options and write a comment in the comment section.

The comment will then appear in the comment section whenever the curve is selected.

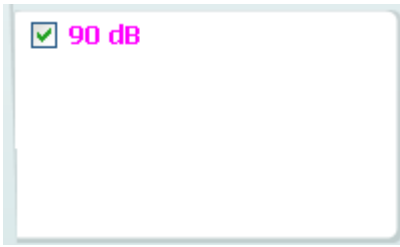

Curve Display Options are found in the lower right-hand corner.

If you have measured more curves of the same type (e.g., Frequency response curves), they will be listed by their input level. Tick the ones that are to be displayed on the graph. Right clicking on this option will allow you to change the curve's color or delete the curve.



Callisto™ 2.0: The picture indicates whether the hardware is connected.

When opening the Suite, the system will automatically search for the hardware. If it does not detect the hardware it will continue in simulation mode.

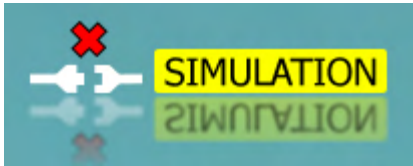



3.6 Hearing instrument testing using HIT440

Hearing Instrument Testing (HIT) is performed to verify that the hearing aids are technically functioning as they should. It is usually performed after fitting the hearing aid or during a repair appointment.

When performing HIT there are certain things you should keep in mind to get the best possible result. Some of these will inevitably also influence the precision of the curve obtained. This section will walk through some important tips and tricks to remember when tasking hearing aids using the HIT440.

The following section will provide you with general knowledge relevant for hearing instrument testing using the HIT440.

Correct placement of a hearing aid in the test box

Positioning the hearing aid correctly in the test chamber is important to obtain precise measurements.

3.6.1 Testing hearing instruments:

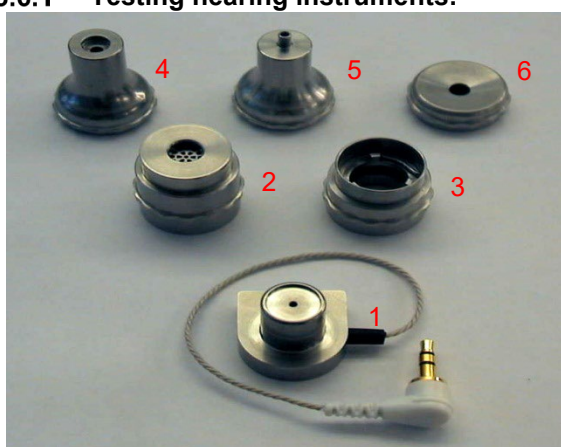

- 1) Coupler microphone
- 2) Ear simulator/711 coupler (optional)
- 3) 2cc coupler
- 4) Adaptor for body worn hearing aids
- 5) Adaptor for BTE hearing aids
- 6) Adaptor ITE hearing aids

- 1) Connect either the 2cc coupler or the 711 coupler to the coupler microphone and attach the relevant adaptor to the coupler. The parts will click easily together.

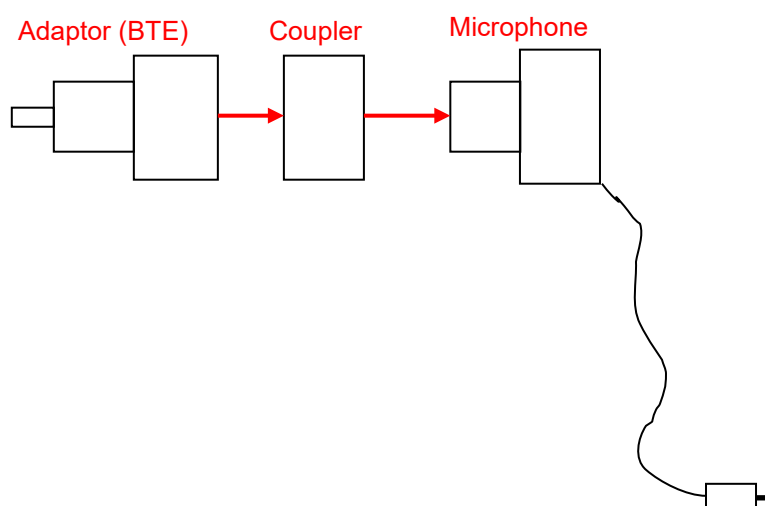

- 2) Attach the hearing aid to the adaptor. To attach a BTE use the BTE tubing that is delivered with the system, as shown below.



- 3) In case of an ITE or open fit hearing aids use blue putty to attach them to the ITE adaptor as shown below:





3.6.2 Running pre-programmed test protocols

1) Place the hearing aid in the test box (as described in section 0)

2) Select the appropriate ear



Select a test protocol



START

Select START to run the test automatically

The Auto Run function will ensure that all test in the protocol is performed automatically. The tests included automatic test flow will be marked with a .

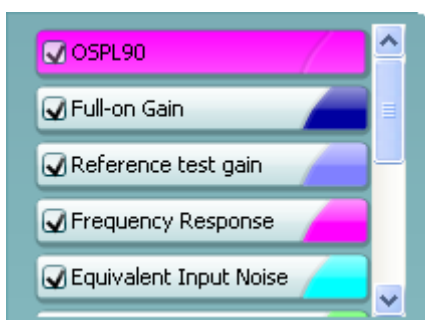

3.6.3 Automatic testing (auto run)

Auto Run ensures that the tests in the test protocol are run as an automatic test flow meaning that all tests are performed when pressing START. Tests included in the Auto Run is marked with a in the test screen.

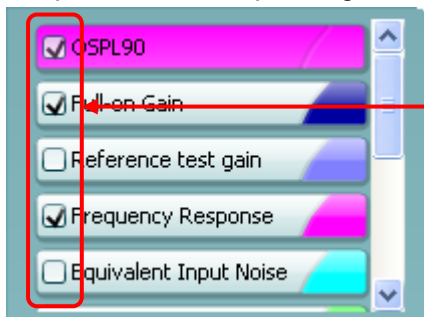

Auto Run check marks

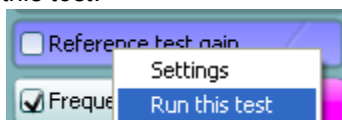

ONLY the tests marked with a will be performed when pressing START. To run the remaining tests these, need to be activated manually. This is done by clicking on the relevant test, then right clicking and select *Run this test*.



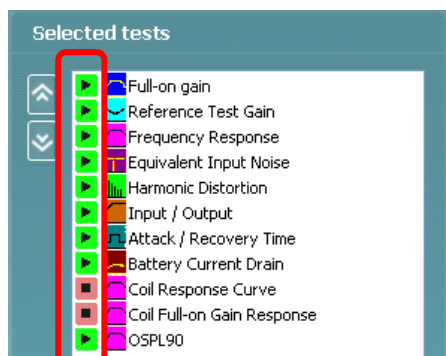

Auto Run can be setup in the HIT440 setup (**Menu/setup/HIT440 setup**).



Next to each test you will find a *Play* symbol (Auto Run)  or a *Stop* symbol (Manual Run) . Click on the *Play/Stop* symbols for each test to toggle between Auto and Manual Run. See more information about protocol setup in section 3.8.

3.6.4 Preconditioning and sweep delay

3.6.4.1 Preconditioning

Preconditioning is relevant when using broadband signals such as for example ISTS/ICRA. It consists of a **wideband signal followed by a pure tone appearing just before the selected stimulus is presented.** The precondition function allows you to set a certain time before the curve is shown on screen. This will allow the hearing aid algorithms to have time to switch on and stabilise in a setting as caused by a non-linear stimulus. This has two effects – first you will avoid the hearing aid being in the process of changing characteristics during the test, and secondly, the hearing aid will in this case be brought into the mode corresponding to the stimulus.

3.6.4.2 Sweep delay

The sweep delay is the time before the next sweep will start when running a continuous measurement using Pure Tone or Warble Tone. Modern hearing aids often have advanced algorithms that need a certain reaction time. It is therefore helpful to be able to set individual delays.

3.6.5 Smoothing a curve

Smoothing is a technique where small details in the curve appear to be ironed out. As these details sometimes have a noisy character, smoothing may be preferred. The individual tests can be designed to have smoothing applied in the HIT440 setup (described for each test in section 3.8).

Smoothing can also be applied after measuring in two ways:

- Shift + up/down arrow keys on the PC keyboard
- Shift + the scrolling wheel on the mouse



Examples:

Smoothing index 0



Smoothing index 10



Smoothing index 5



Note: Numerically reported MAX OSPL90 Level is determined from a non-smoothed curve, and as such not affected by smoothing level, even though the smoothed waveform may appear to have a reduced peak around the MAX SPL area.

3.6.6 Show cursor on the graph

When comparing the graph in the fitting software/specification sheet to the graph in the HIT440 the *Show cursor on graph* may be useful. Upon selecting the function, the cursor will “glue” to the highlighted curve showing the exact measured value at each frequency.

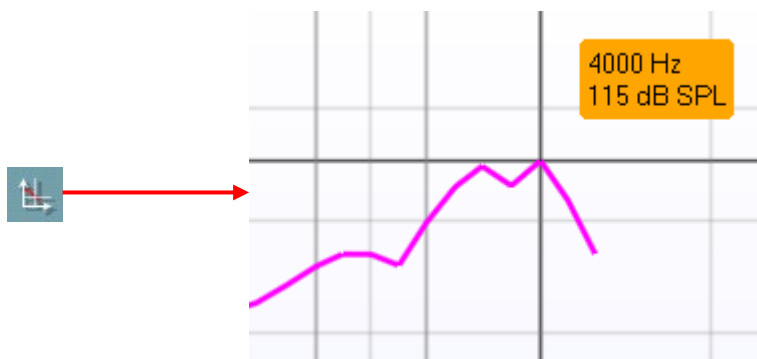

Note: As the cursor tracks the displayed curve, any smoothing applied to the curve will influence the reading. This may have the effect that a smoothed curve will report one max OSPL90 level with the cursor and a different max OSPL90 level in the numerical data section. Unsmoothing will make the two readings identical.

3.6.6.1 Managing multiple curves

If measuring many curves during the same test session, there are several ways to provide a simpler view (or a comparison view) showing only the preferred curves in the same graph.



3.6.6.2 Curve display options

In the curve display options box, all curves are listed by input level and color.

If many of the same curve type (e.g., Frequency Responses) have been measured tick only the ones that you wish to display on the graph.

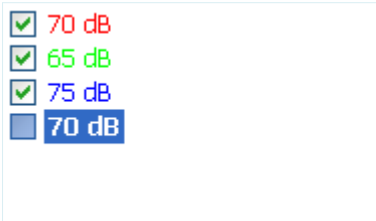

Un-ticked curves will be hidden ensuring a less confusing screen view.

3.6.6.3 Combined screen view

If a combined screen is setup you may want to compare to other curves obtained. Press the corresponding button to toggle between single and combined screen:



In the combined screen setup, you can decide exactly which curves are to be compared so that for example pressing the combined screen button results in a comparing multiple Frequency Responses (see section 3.8.3 for how to do a combined screen setup).

3.6.6.4 Changing the curve color

If having many curves on screen you can change their colors even after they are measured. Right click on the preferred curve and choose *Change curve color*. The system will then allow for choosing a new color.

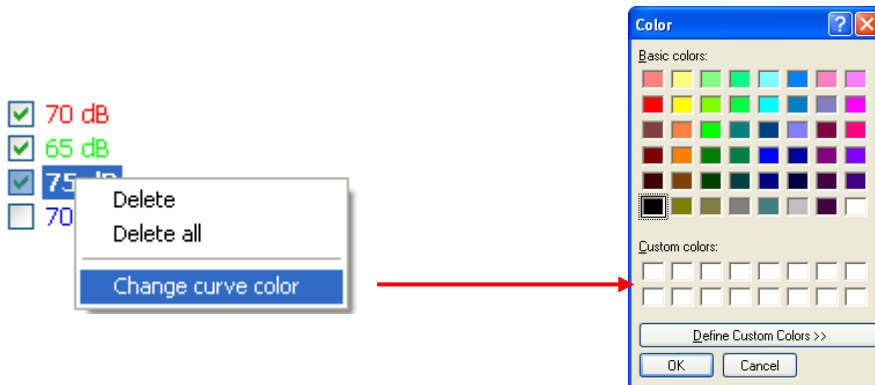



3.6.7 Comparing curves

The HIT440 also allows for comparing either two historical curves (e.g., two OSPL90 curves) or comparing a historical curve to a currently recorded curve. This is done following the procedure described below:

- 1) Find the first curve in the *Session list*. Historical HIT measures are listed by date and time of saving.

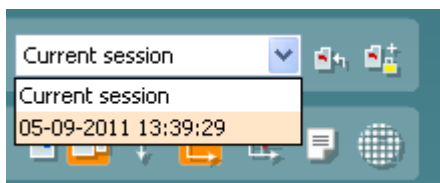

- 2) Press *Toggle between lock and unlock the selected session*
- 3) Find the second curve in the *Session list*. This can be either a curve of the current session or a historical curve.

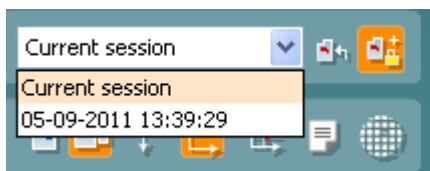

The two curves are now shown in an overlap view as illustrated below:

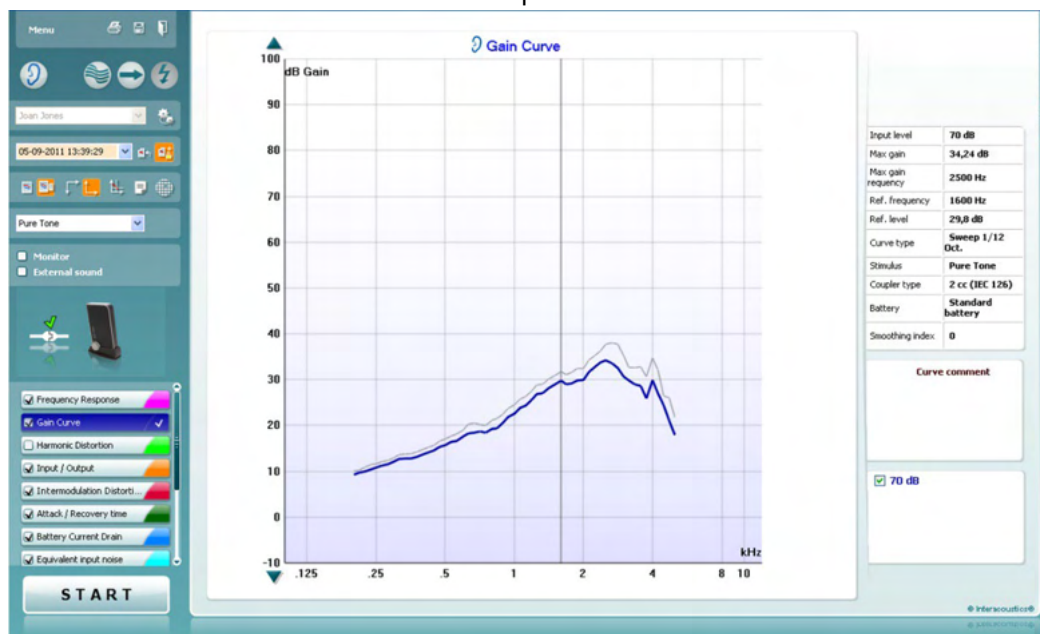

Note: To avoid comparing apples to oranges, only curves of the same type can be compared – hence it is not possible to compare results from an ANSI based test protocol with curves acquired with an IEC or Custom based test protocol. Ideally the same test protocol should be used for this type of comparison.



3.6.8 Comparing to the manufacturer's specification sheets

When comparing a measurement to the hearing aid manufacturer's specification sheet it is important keep in mind that **the same hearing aid settings that were used in the specification measures should also be used for the HIT440 measures!** If the parameters are not accordance with each other the comparison will not be valid.

Most hearing aid manufacturers use known international standards, such as the ANSI or IEC for their specification sheets. The same standard can usually be selected in the HIT440 software.

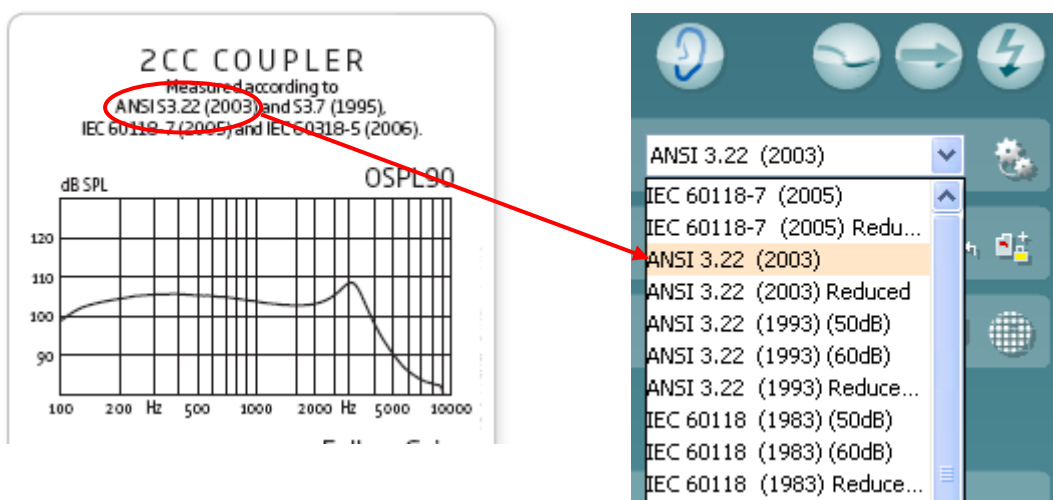

The hearing aid can typically be programmed with a “technical measurements” setting found in the fitting software (please refer to the manuals of the specific hearing aid brands for details). These ensure correct settings for the ANSI/IEC comparisons.

If you do not use international standards, please be sure to check the following:

- Ensure that the *stimulus* used in HIT440 is the same as in the specification sheets
- Ensure that the *input level* used in the HIT440 is the same as in the specification sheets
- Ensure that the hearing aid is programmed with the exact same *gain settings* as used in the specification sheets.



3.7 Application of the HIT440 tests

3.7.1 Frequency response

The frequency response equals the absolute sound level delivered by the hearing aid at each frequency expressed in dB SPL. Prior to the measurement remember to perform the Reference Test Gain and set the volume control to the correct position.

The frequency response curve gives you an overview of the hearing aid response and can thereby serve as a verification procedure making sure that the hearing aid is providing the needed response.

Below an example:

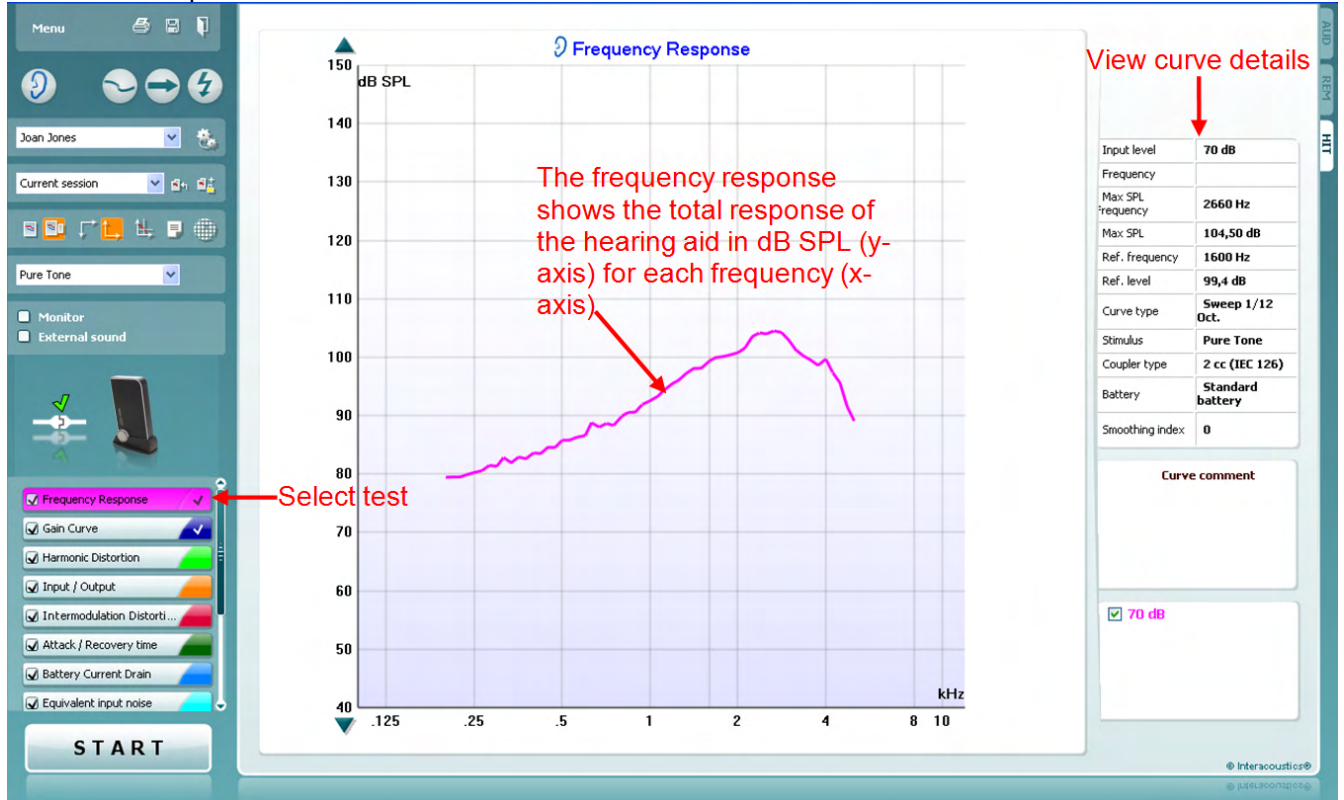



3.7.2 Gain curve

The gain curve is identical to the frequency response described above. The only difference is that the input level is subtracted from the frequency response providing you with pure hearing aid gain.

Below an example:





3.7.3 Harmonic distortion

The pure tone components are called harmonics and occur at integer multiples of the fundamental frequency. The output of a hearing aid, however, is rarely a pure tone and the signal will inevitably contain elements at different frequencies not included in the input. These components are defined as distortion products. As a result, measuring these is called *Harmonic Distortion*.

Harmonic distortion can be measured by presenting a pure tone to the hearing aid and analysing the waveform of the output to measure the distortion components relative to the total power of the input signal. The *Total Harmonic Distortion* (THD) equals the total sum of all harmonics or in the Callisto™ the 2nd and 3rd harmonic. The result is expressed relative to the wanted output signal component in percent.

It is important to know the harmonic distortion to be assured that the output of the hearing aid is not affected by unwanted distortion. Distortion can be compared to *the cocktail party effect* as harmonics (noise) may mask the wanted speech signal (fundamental frequency). A hearing aid with high distortion will therefore not provide the client with the ideal speech understanding.

Below is an example:





3.7.4 Input/output

The Input/Output curve displays the output of the hearing aid as a function of the input for one frequency (or broadband signal).

The Input/Output function provides information about the compression characteristics of the hearing aid such as for example expansion, knee-point, and compression limiting.

Below is an example:

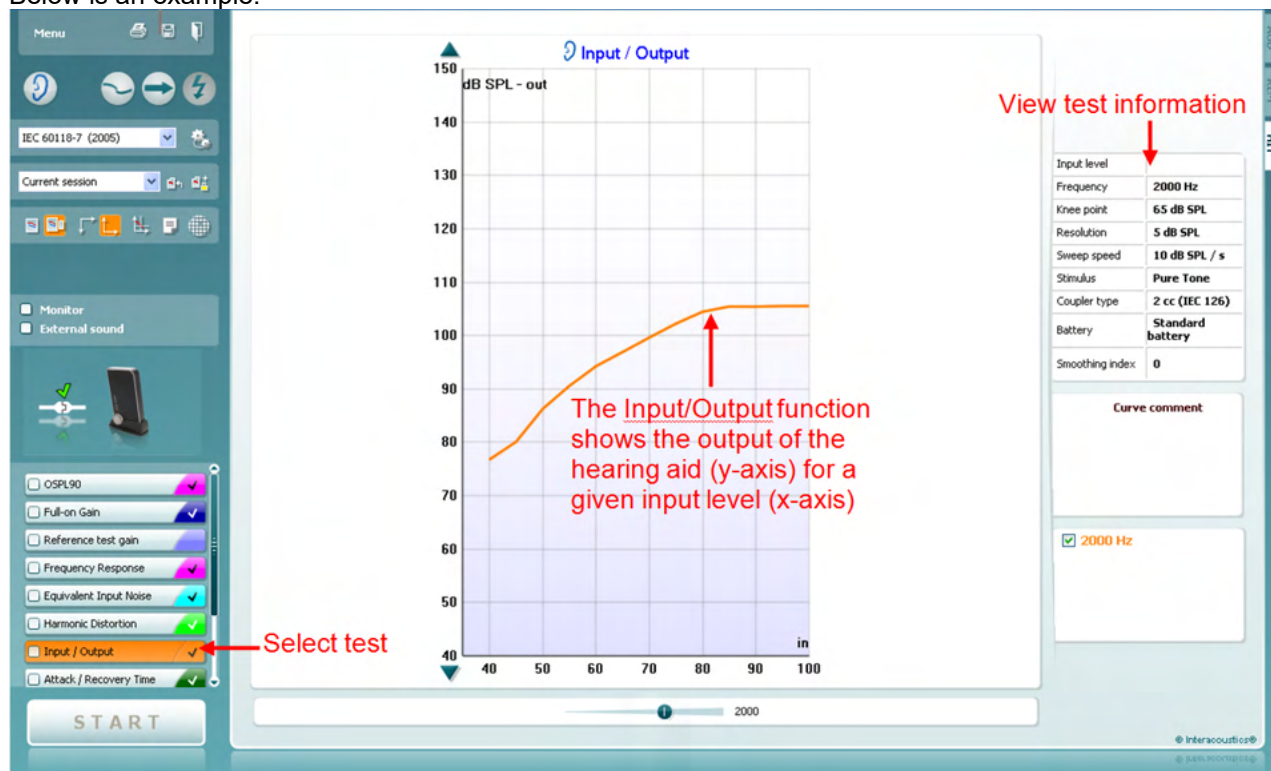



3.7.5 Intermodulation distortion

Distortion in moderate-severe amounts will inevitably have a negative effect on the quality of speech and speech intelligibility. To assess the distortion product generated by the hearing aid, intermodulation distortion is measured.

Two tones equal in amplitude are presented to the hearing aid: one at the selected frequency difference (f_1) and one at the selected frequency (f_2). The HIT440 will make an FFT of the signal produced by the hearing aid and the 2nd and 3rd intermodulation distortion is calculated.

2nd distortion: the signal at $f_2 - f_1$ in relation to the signal at f_2 .

3rd distortion: the signal at $2 \cdot f_1 - f_2$ in relation to the signal at f_2 .

Below is an example:

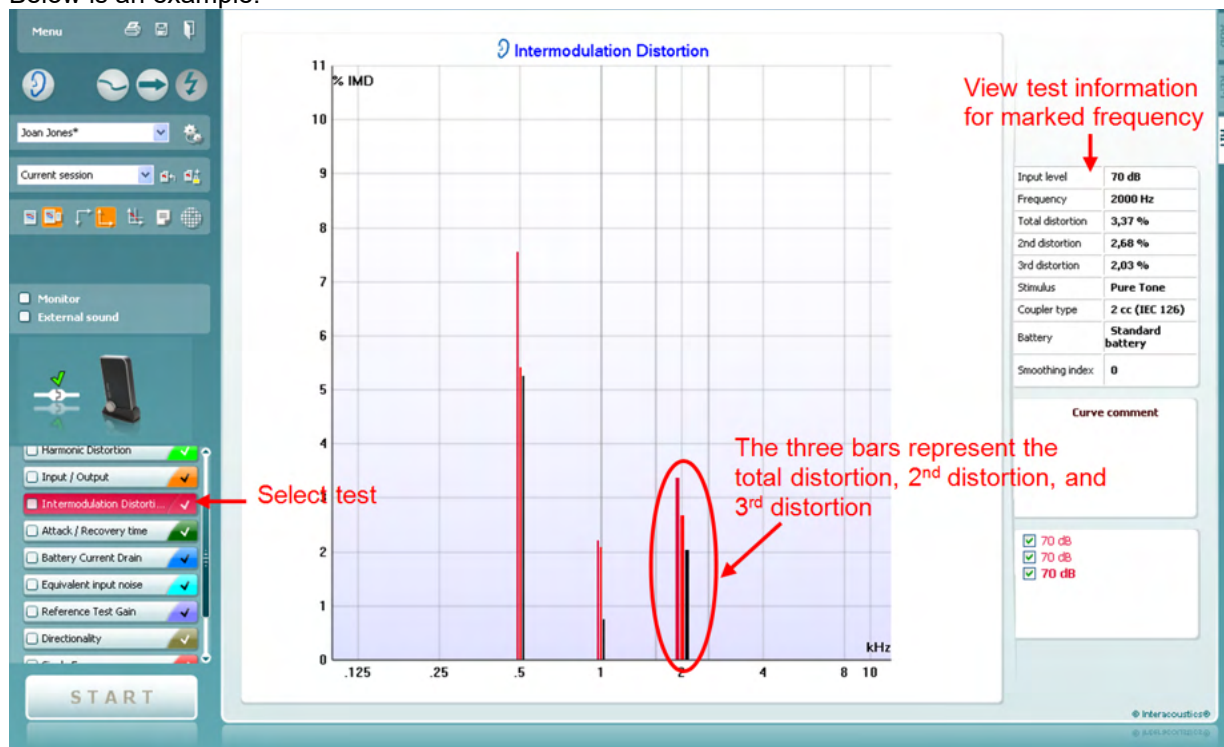



3.7.6 Attack/recovery time

The Attack time is the time it takes for the hearing aid compressor to react to an increase in input signal. As the output will gradually move towards the final gain value it has been decided to define the attack time as the time it takes the hearing aid to stabilize the output within 2 or 3 dB according to the IEC 6018-2 and ANSI S3.22 respectively. The attack time is commonly 5 ms but can be longer.

The Recovery is the time taken for the hearing aid compressor to react to a decrease in input level. As the output will gradually move towards the final gain value it has been decided to define the recovery time as the time it takes the hearing aid to stabilize the output within 2 (following an input decrease from 80 to 55 dB) or 4 dB (following an input decrease from 90 to 55 dB) according to the IEC 118-2 and ANSI S3.22 respectively. The release time is commonly 20 ms but can be longer.

Measuring the attack and recovery time gives you an idea of the time constants within the hearing aid and how fast it reacts to incoming sounds. If the recovery time is too short the gain will vary too much during speech that shifts quickly in amplitude, phase, and frequency. This will distort the signal. In hearing aids with short attack time and long recovery time the distortion will be minor. The main disadvantage in this case will be extremely brief sounds such as a door slamming will cause the gain to decrease as the attack time is short. However, the gain will stay low for a while due to the long recovery time which may result in the client missing information during this period.

Note: If using the IEC standard this test should be performed with the volume control in its maximum position (e.g., before Reference Test Gain)

Below is an example:

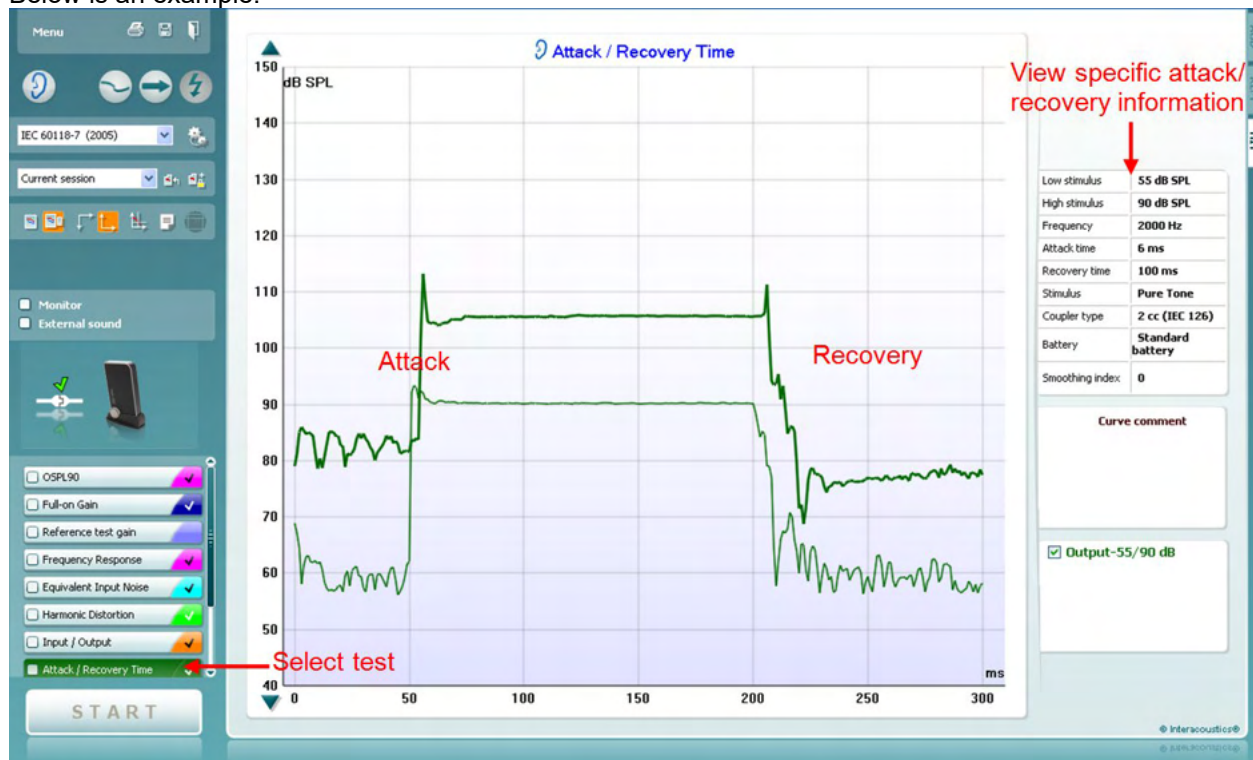



3.7.7 Equivalent input noise

Every amplifier and microphone will generate noise to some extent. The internal noise of a hearing device is expressed as the Equivalent Input Noise. More specifically this term covers the amount of noise that would need to be added to the input of a noiseless hearing aid with the same frequency response if the noise coming out is to be the same as the tested hearing aid.

According to Dillon (2001) there are three reasons as to why it makes sense to express the noise relative to the input:

- Most noise in good quality hearing aid comes from the microphone and most of the remaining noise comes from the input amplifier.
- The noise of the output will vary with the position of the volume control in hearing aids with volume control. This is not the case with the input related noise
- If the noise was expressed relative to the output hearing aids with little gain would always have less noise than hearing aid with high gain.

The Equivalent Input Noise is performed by measuring the noise of the hearing aid output followed by subtracting the gain.

$$\text{Output noise} - \text{Gain} = \text{Equivalent Input Noise}$$

Below is an example:



Note: Equivalent Input Noise can be displayed as a curve or figure depending on your preference.



3.7.8 Reference test gain

Reference Test Gain is a control position which is usually set after doing the high-level measures such as OSPL90 and Full-on gain. If this is the case the result is a basic frequency response (IEC 118-0) or frequency response curve (ANSI S3.22). If using the IEC, the volume control is adjusted against a 1.6 kHz tone which with an input of 60 dB should produce an output 15 dB less than the OSPL90 at the same frequency. For hearing aids fitted to very high frequency hearing losses the reference test frequency is changed to 2.5 kHz. In the ANSI standard the procedure is identical; only the test is run at three frequencies 1, 1.6, or 2.5 kHz. The HIT440 Setup allows for applying both the ANSI and IEC procedure depending on the preference of the professional. A customized version combining elements from the two may also be established.

Reference Test Gain is performed as described in section 3.7.1. While the test is running adjust the volume control to the target line.

Below is an example:





3.7.9 Microphone directionality

Unwanted noise is provided by many different sources in many daily life situations. They can come from different directions due to position or reflection from the walls in the environment. Fortunately, many digital hearing aids have directional microphones that suppress noise coming from some directions while maintaining a good sensitivity to sounds coming from another direction. This is done to give the user an advantage so that they are more likely to hear the signals they want over the noise in a noisy environment. This effect can be measured in the TBS10 test chamber.

As the TBS10 only has one speaker the hearing aid will need to be rotated for each condition. First a frequency response is performed with the Hearing Aid positioned in one direction. After this you should turn the hearing aid over, and a similar curve will be recorded for another direction. Then the second curve is subtracted from the first and results in the directionality curve.

Note: When the TBS10 is used for directionality testing the small size of this chamber will of course have a considerable effect on the directionality results. Under such circumstances the test results will be different from results obtained in manufacturer's huge fully damped anechoic rooms.

To obtain the best results with the TBS10 from this test, allow the lid to be open during the test. As stimuli are relatively strong for such tests, and as the test is being carried out in the 1kHz to 4kHz range only, this will be possible in most office environments.

This way you can get a test of how the hearing aid directionality functions under these conditions. If you repeat the test with the hearing aid and the reference microphone in the exact same position (very important), then the test results will be duplicated. This means that you can use the test to verify that the directionality is unchanged over time when you repeat the test at any later time. This can be good verification from a technical standpoint as well as in convincing a client that hearing aid directionality function has remained unchanged.

Below is an example:

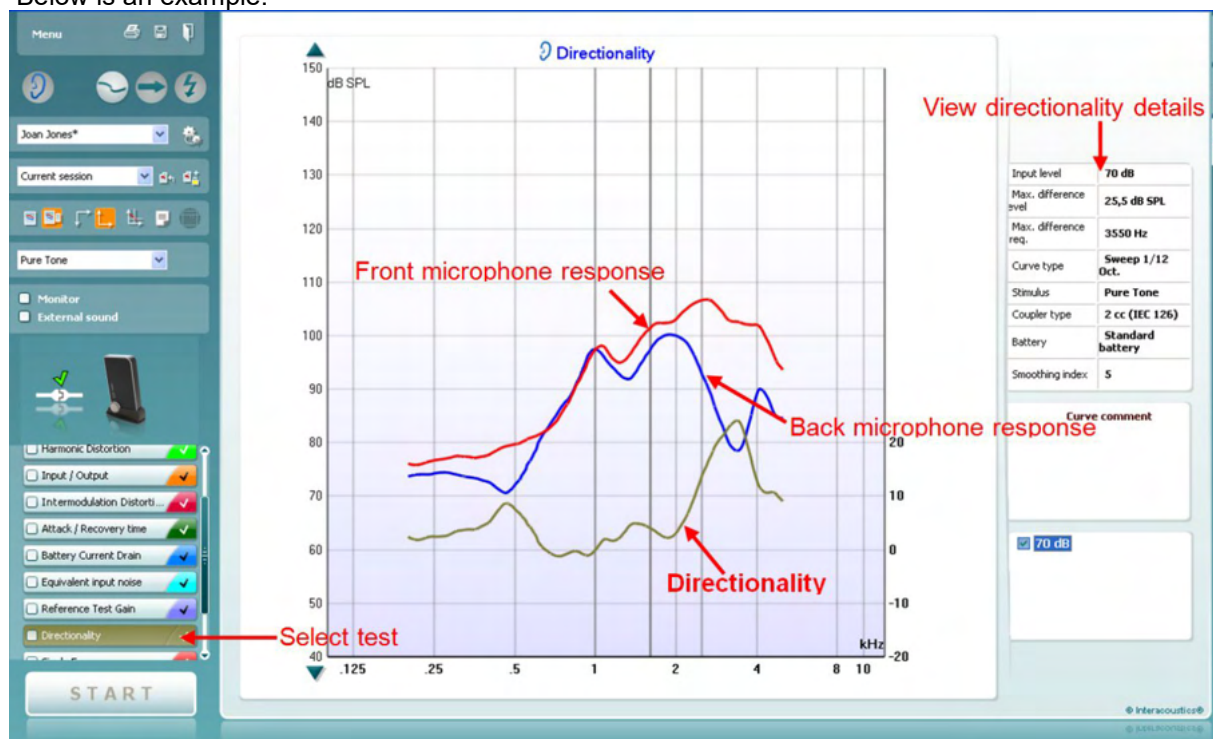



3.7.10 Single frequency

Single Frequency tests the hearing aid at a single selected frequency using a given stimulus. This allows you to get an impression of the hearing aid at specific important frequencies.

If selecting a pure tone or warble tone stimulus a bar representing the fundamental frequency together with harmonics will appear on the graph. If selecting a noise stimulus, a FFT spectrum shows on screen.

The Single Frequency measure is useful to see how much the hearing aid distorts the signal.

Below an example:





3.7.11 Response/gain/input/output

The Response/Gain/Input/Output is a combination screen showing the frequency curve, gain curve (one or both) and input/output curves. Response/Gain/Input/Output is performed as described in section 3.7.11.

Below is an example:

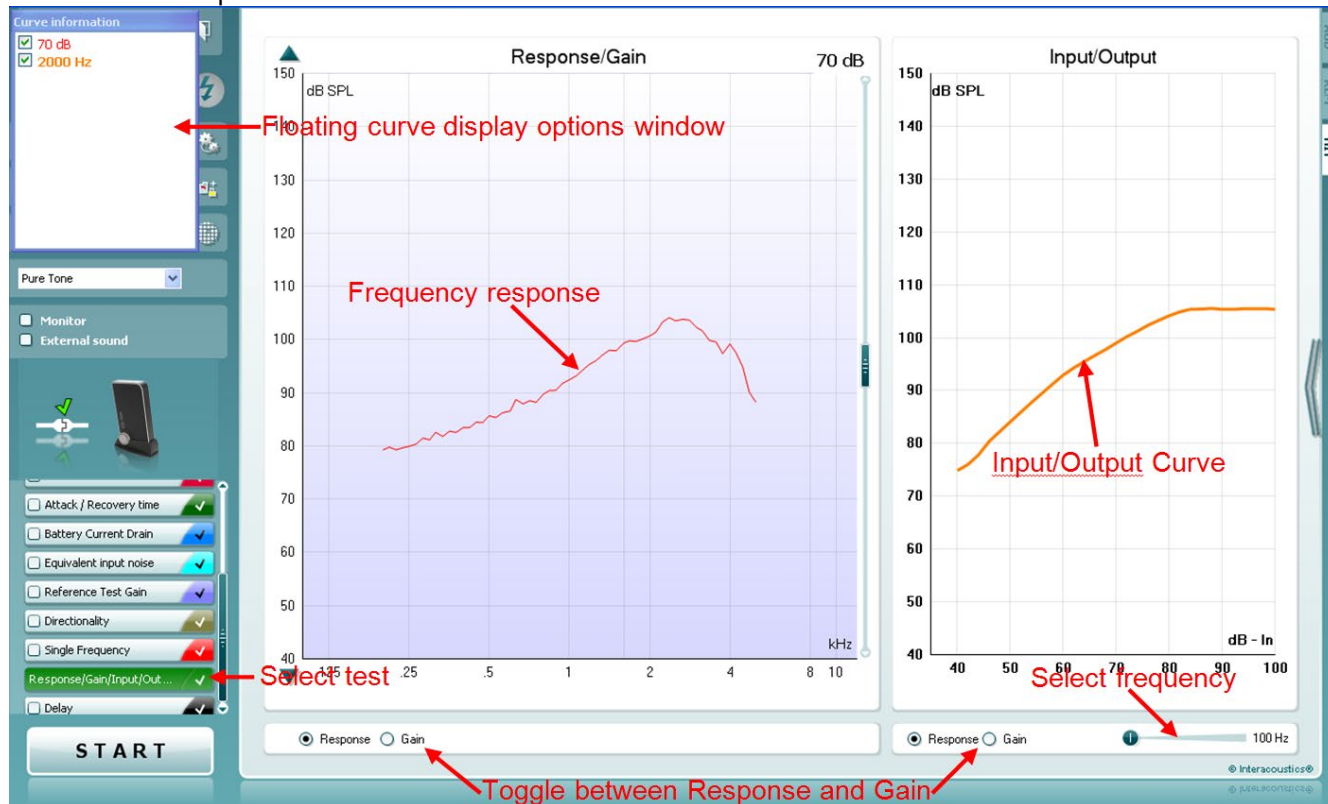

Note the option to toggle between **Gain**, **Response** or **Both** view below the graphs:

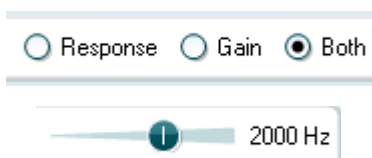

Also note that you can change the frequency of the Input/Output measurement using the slider below the graph:



3.7.12 OSPL90

The OSPL90 is defined as the maximum output level of the hearing aid measured at an input level of 90 dB. This input level has been chosen as standard as it is enough to saturate the hearing aid in most cases except if the volume control is set to an extremely low level.

The OSPL90 is often used when doing paediatric fittings in the coupler. This way you can ensure that the output of the hearing aids never becomes uncomfortable for the child. It can, however, be recommended that the hearing aid maximum is evaluated on all clients.

Below is an example:





3.7.13 Full-on gain

Full-on Gain is the amount of gain measured in a hearing aid with volume control set to its maximum. It usually measured at an input level of 60 dB which is a common most comfortable level (MCL). When measuring the full-on gain, you thereby can check that even at a high output the gain stays below the uncomfortable level (UCL).

Below is an example:





3.8 Working with individual setups (test protocols)

The HIT440 module is pre-programmed with standard test protocols (IEC and ANSI) ready for use which can be selected from the front screen. However, you may wish to create an individual test protocol accommodating for personal preferences and test methods.

This section describes both how to select a pre-programmed test protocol and how to create an individual test protocol.

3.8.1 Selecting a (standard) test protocol:

1. Open the Callisto™ Suite from Noah, OtoAccess®, or stand-alone.
2. Go to the HIT440 by clicking the HIT tab.



3. In the **List of Protocols** all customized and standard test protocols are listed.

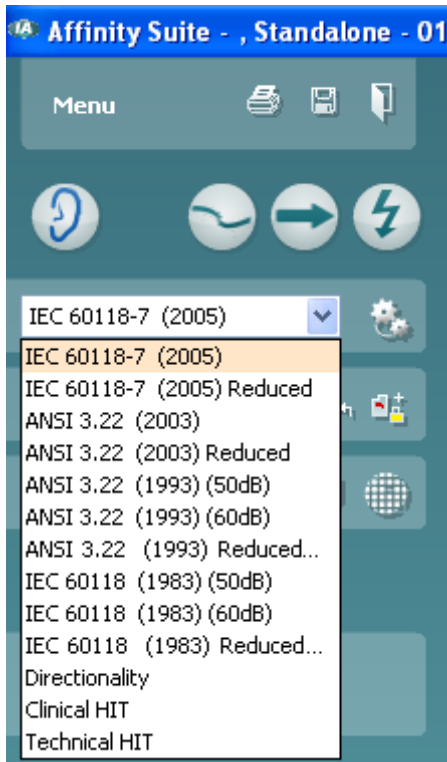



3.8.2 Designing a customized test protocol

The following sections describe how to setup your own test protocol in the HIT440 setup. All setup options for all tests will be described even though you most likely will only need a few. This section is therefore to be seen as a work of reference where single functions can be looked up rather than a step-by-step guide where all steps need to be explored.

- 1) Enter the REM440 setup by pressing **Menu/Setup/HIT440 setup**.

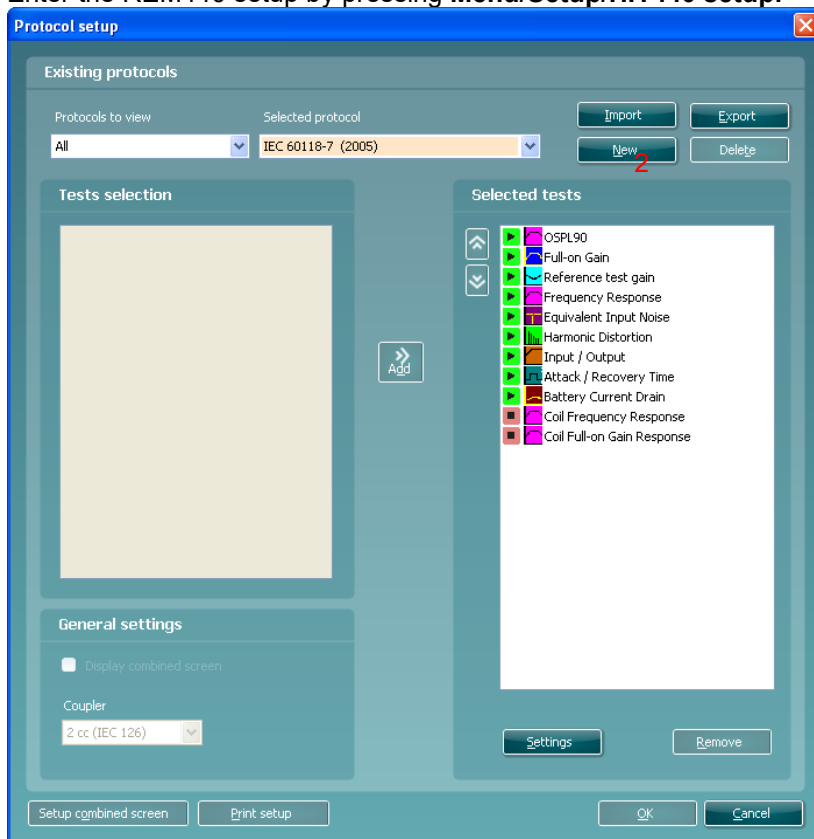

- 2) Press **New**.
- 3) A pop-up will ask whether the new test protocol should be based on a copy of the currently selected test protocol. When asked by the message box:

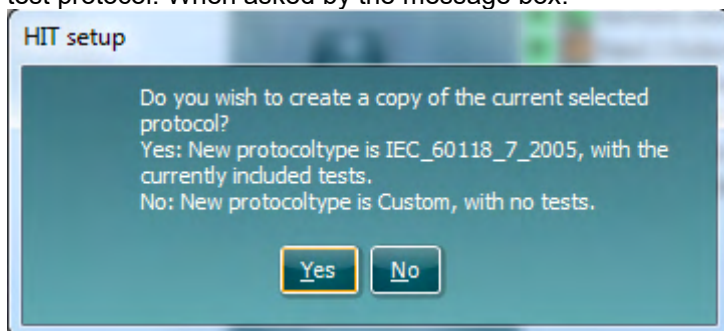

Yes: The system will create a copy of the current test and allow you to add new tests, make changes, and save it under a new name.

No: The *Selected tests* section will be blank, and you can create a new test from scratch.

- 4) Name the test protocol setup in the **Selected protocol** section.



- 5) Select the tests to be included in the test protocol. Mark a test by clicking on it and press the **Add**. Double clicking on a test will also select it.

Choose all the tests for the test protocol using this procedure.

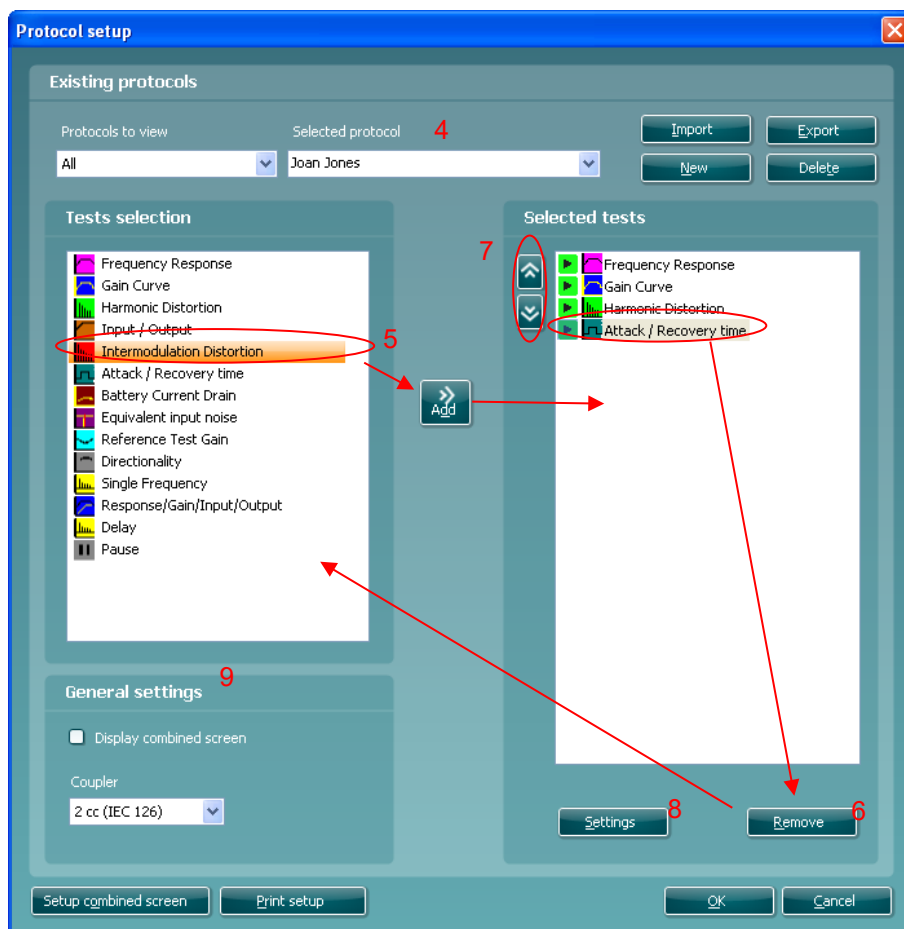

- 6) To remove a test selected by mistake, mark it under *Selected tests* and press **Remove**. The test will then jump back to the *Test selection* list.
- 7) If the order of the tests is to be changed, use the two **Move** arrow buttons. Mark the test to be moved and press one of the arrow buttons. Depending on the direction of the selected arrow, the test will then jump up or down.
- 8) To adjust the parameters of each selected test press **Settings**.
- 9) In **General settings** find the following additional options:

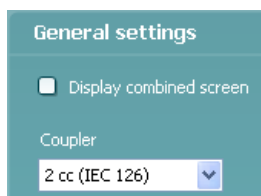

Display combined screen allows for comparing different curves by default in the same graph. The option is also available from the front screen. Which curves to compare can be setup individually (see section 3.8.3).
Coupler allows you to select the preferred coupler to be used in the test protocol. Select from *0.6 cc*, *1.2 cc*, *2 cc*, and *Ear simulator (IEC 711)*. The skull Simulator will appear here if the license for it exists in your Callisto™ unit.



Note: Prior to creating a new test protocol you may wish to select a protocol type in the *Protocols to view dropdown list*. This function is practical if you for example wish to create a new protocol based on elements from the ANSI or IEC standard. In this case the dropdown list can be used to select an ANSI or IEC standard before clicking *New*. When asked if the new protocol should be based on a copy of the currently selected protocol, click *yes*.

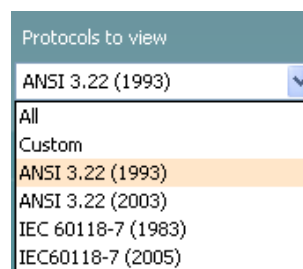

3.8.2.1 Frequency response settings

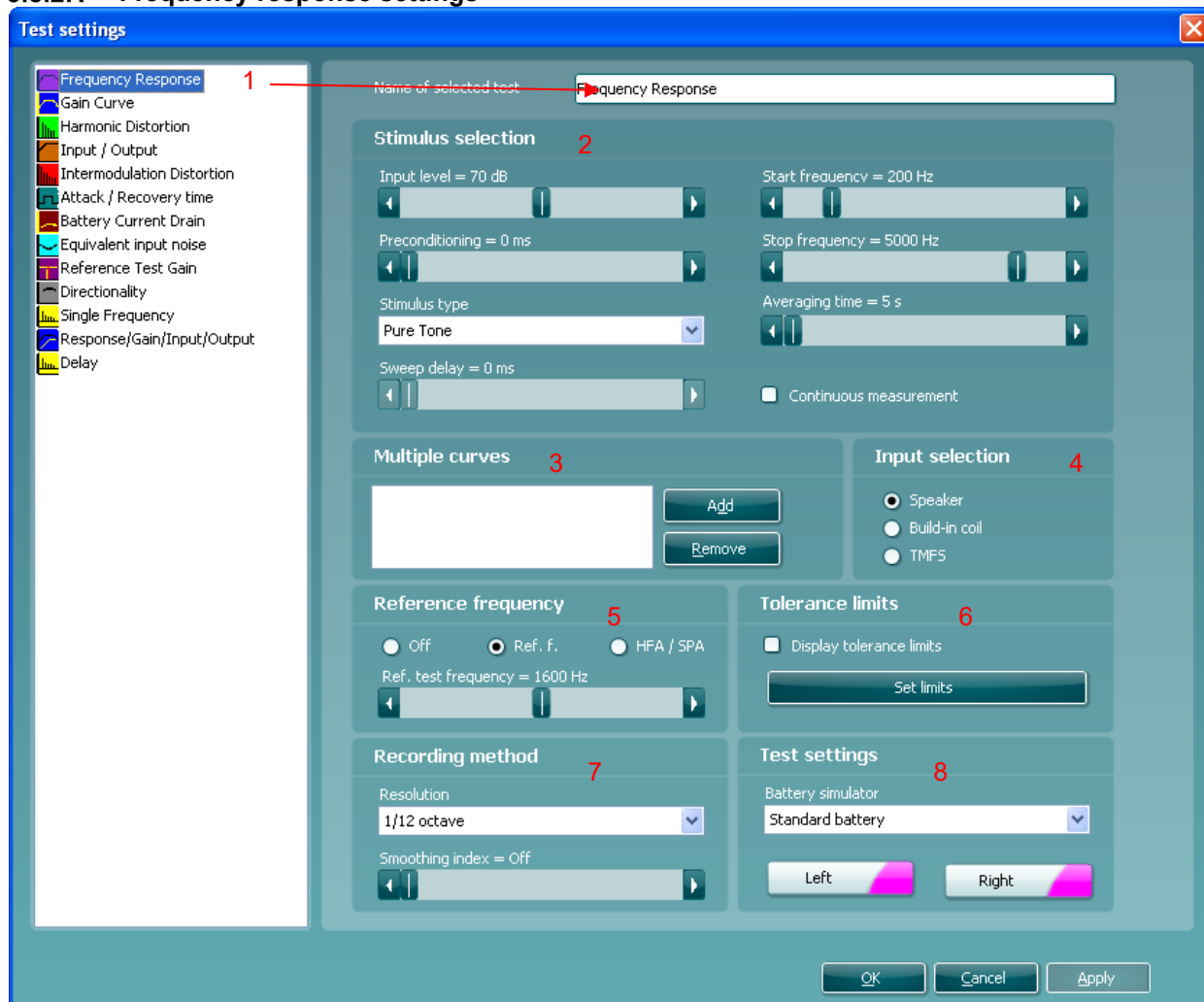

- 1) Ensure that **Frequency Response** is marked in the left-hand side of the screen. The name of the test will then appear in the *Name of selected test* section. Note the option to write a new name for the test in this section (e.g., “Frequency Response 65 dB input”)
- 2) **Stimulus selection:**
 - *Input Level:* Set the input level using the slider.
 - *Preconditioning:* This is relevant when using broadband signals such as ICRA (see section 3.6.4.1 for details). Select a duration using the slider.
 - *Stimulus type:* Select a stimulus using the dropdown list (See stimulus list in section 3.12.1).
 - *Sweep delays:* This is relevant if *Continuous measurement* is selected for Pure Tone or Warble Tone. In this case sweep delays (in milliseconds) may be entered between the individual sweeps (see section 3.6.4.2 for details).



- **Start Frequency and Stop Frequency:** Select the preferred frequencies using the sliders. To avoid low frequency noise set the slider to a start frequency of 200Hz.
- **Averaging time:** Decide the number of FFTs shall be used for the averaging of non-linear stimuli like ICRA noise, real speech, or other wave-based stimuli. The longer average the more reproducible test results will be.
- **Continuous:** This check box allows you to make the measurement ongoing rather than a single sweep. This may, however, also be done in the front screen using the continuous button:



When continuous is ticked, the stimulus and recording will continue until you press the STOP button.

3) Multiple curves:

- If you wish to have multiple curves at different input levels in the same graph, use the Multiple Curves option. Set the first level using the *Input level* slider and press *Add* under **Multiple Curves**. The level will then appear in the corresponding white section. Select the second level and press *Add* again. The new level will then be listed below the first one. Follow this procedure until the preferred number of curves has been achieved. If a level is selected by mistake click mark it in the white section by clicking on it and press *Remove*.

4) Input selection:

- Frequency Response should be performed through the *Speaker* as this is the only method of stimulation through the Callisto™ and TBS10.

5) Reference frequency:

- **Ref f:** Tick this option to select a single reference frequency using the slider. After measuring the curve, the level at the reference frequency will be displayed in the measurement details table.

The control panel shows 'Ref. f.' selected with a radio button. The 'Ref. test frequency' is set to 1000 Hz. A red arrow points from the control panel to the measurement details table.

Input Level	70 dB
Max SPL	111,48 dB
Max SPL Frequency	400 Hz
Ref. frequency	1000 Hz
Ref. level	110,4 dB
Curve type	Sweep 1/3 Oct.
Stimulus	Pure Tone
Coupler type	
Battery	Standard battery

- **HFA/SPA:** Tick this option to select three frequencies at a fixed distance using the slider. After measuring the curve, the reference frequency average will be displayed in the in the measurement details table.

The control panel shows 'HFA / SPA' selected with a radio button. The 'HFA' is set to 1000, 1600, 2500 Hz. A red arrow points from the control panel to the measurement details table.

Input Level	70 dB
Max SPL	118,57 dB
Max SPL Frequency	2660 Hz
HFA frequencies	1000, 1600, 2500 Hz
HFA level	117,3 dB
Curve type	Sweep 1/24 Oct.
Stimulus	Pure Tone
Coupler type	
Battery	Standard battery



6) Tolerance limits:

- **Set limits:** Press the button to define individually preferred tolerance limit values. By applying tolerance limits to the recording, it will be possible to easily document whether a curve is inside tolerances or not. In the Tolerance, limits screen tolerance limits may be entered as numerical frequency specific values for **Low limit** and **High limit**. Alternatively, Lower Limits and Higher Limits may be entered by clicking with the mouse directly on the dots in the co-ordinate system and dragging them to the preferred position.
- **Display Tolerance Limits:** Tick the box to activate the tolerances which will then be shown on the graph in the front screen.

Note: In the General Setup it is possible to set a warning, which will pause the test and prompt the user if a recording falls outside tolerance limits.

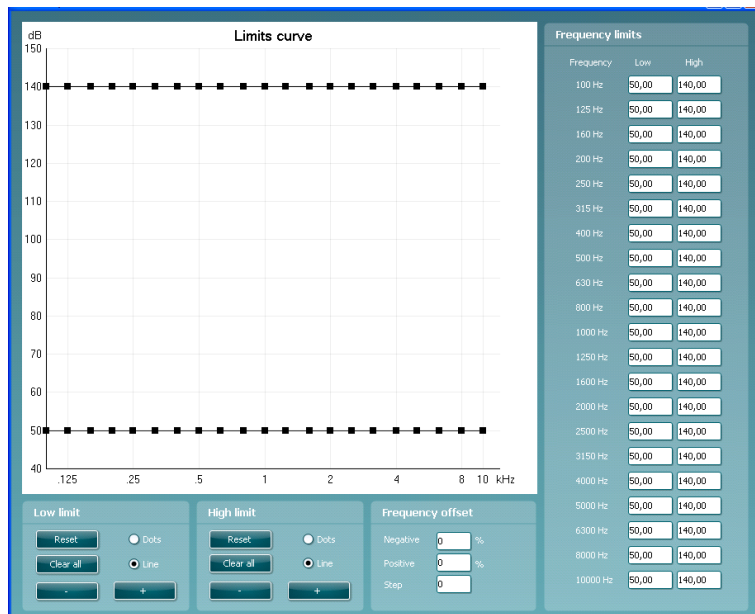

7) Recording method:

Resolution (of frequency): Select the preferred resolution in the dropdown. The higher the resolution the slower the measurement.

Keep in mind that 1/3 is what is used in many hearing aid manufacturers software. If the curve is to be compared to this, you may consider choosing this resolution. Also note that when using a broad band signal the dropdown list will change to offer weighting instead.

- **Smoothing Index:** You have the option to smooth the measured curve using the slider (see section 3.6.5 for details). The higher index number selected the more smoothing is applied

8) Test settings:

- **Color:** Select a color for the *Right* and *Left* curve.

Press each of the buttons to have the custom color selection below. Choose the desired color by clicking on it and press OK.

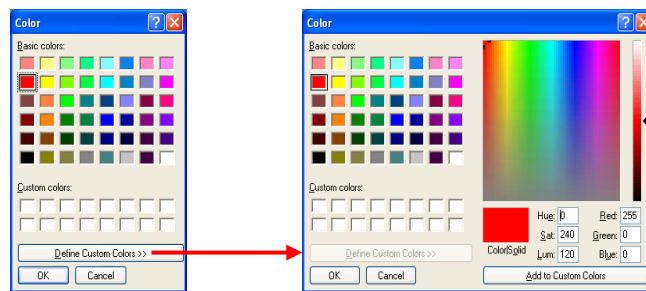

Note the option to *Define Custom Colors* to get a more extensive selection. When having found the exact color, press *Add to Custom Colors*.



3.8.2.2 Gain curve settings

Settings for Gain Curve are identical to the settings described above for Frequency Response.

Test settings

Name of selected test: Gain Curve

Stimulus selection

Input level = 70 dB
Start frequency = 200 Hz
Preconditioning = 0 ms
Stop frequency = 5000 Hz
Stimulus type: Pure Tone
Averaging time = 5 s
Sweep delay = 0 ms
 Continuous measurement

Multiple curves

Input selection

Speaker
 Build-in coil
 TMFS

Reference frequency

Off Ref. f. HFA / SPA
Ref. test frequency = 1600 Hz

Tolerance limits

Display tolerance limits
Set limits

Recording method

Resolution: 1/12 octave
Smoothing index = Off

Test settings

Battery simulator: Standard battery
Left Right

OK Cancel Apply



3.8.2.3 Harmonic distortion settings

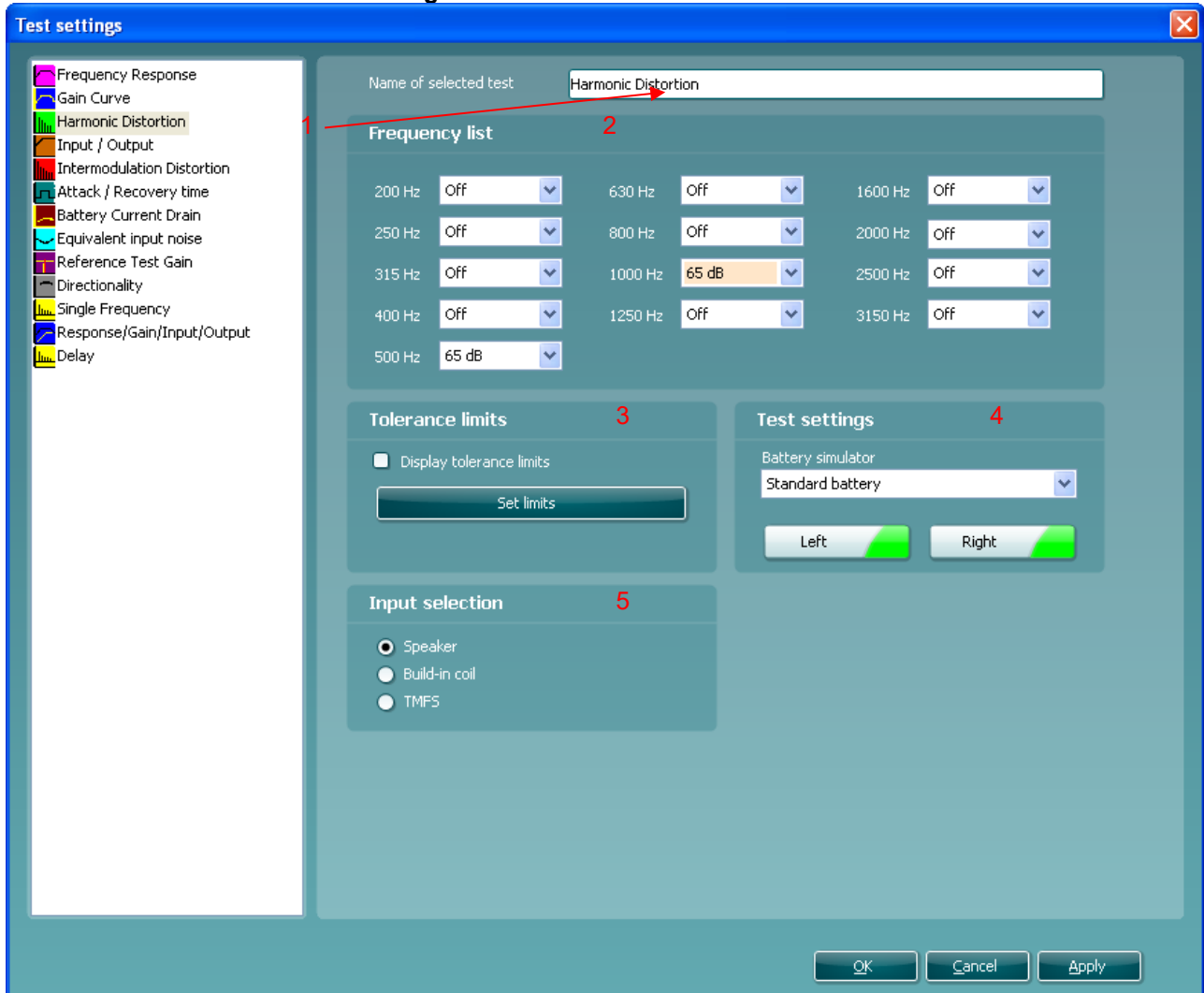

- 1) Ensure that **Harmonic Distortion** is marked in the left-hand side of the screen. The name of the test will then appear in the *Name of selected test* section. Note the option to write a new name for the test in this section (e.g., “Harmonic Distortion 500 and 1000 Hz”)
- 2) **Frequency list:**
 - *Frequency dropdown lists:* Select the frequencies to be included in the distortion measure. Open the dropdown lists of the preferred frequencies and select at which input level the test is to be performed from the selection list.

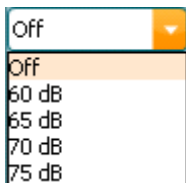

- 3) **Tolerance limits:**



- **Set limits:** Press the button to define individually preferred tolerance limit values. By applying tolerance limits to the recording, it will be possible to easily document whether a curve is inside tolerances or not. In the tolerance limits screen the upper limits may be entered as numerical frequency specific values. Note, however, that this is only possible for the frequencies chosen in the *Frequency list* see point 2) above. Alternatively, limits may be entered by clicking with the mouse directly on the dots in the co-ordinate system and dragging them to the preferred position.
- **Display Tolerance Limits:** Tick the box to activate the tolerances which will then be shown on the graph in the front screen.

Note: In the General Setup it is possible to set a warning, which will pause the test and prompt the user if a recording falls outside tolerance limits.

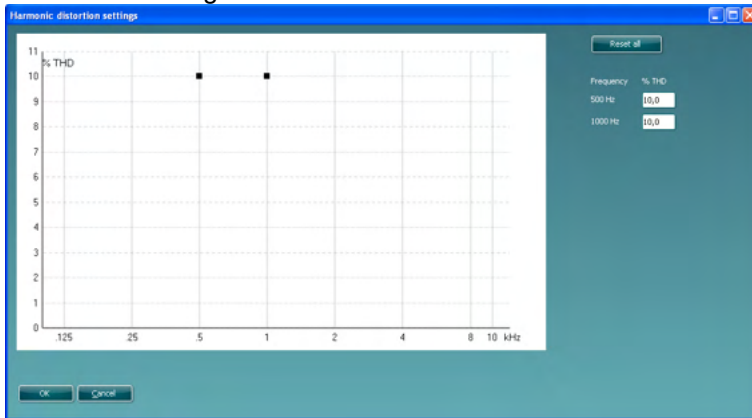

4) Test settings:

- **Color:** Select a color for the *Right* and *Left* curve. Press each of the buttons to have the custom color selection below. Choose the desired color by clicking on it and press **OK**.

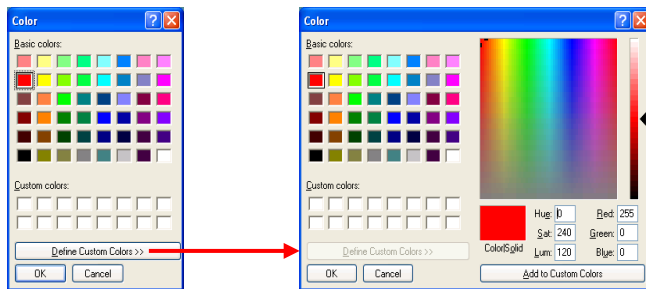

Note the option to *Define Custom Colors* to get a more extensive selection. When having found the exact color, press *Add to Custom Colors*.



3.8.2.4 Input/output settings

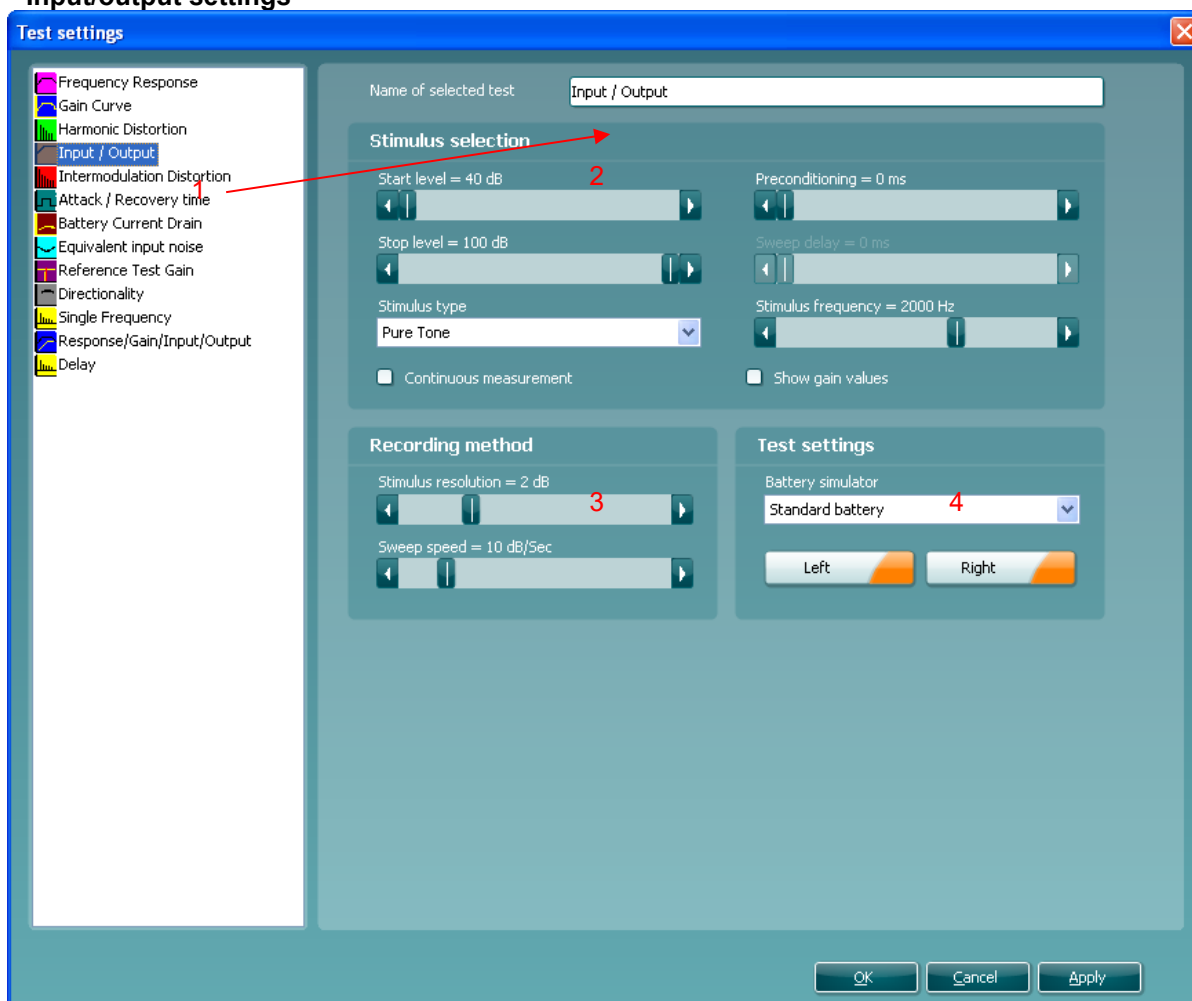

1) Ensure that **Input/Output** is marked in the left-hand side of the screen. The name of the test will then appear in the *Name of selected test* section. Note the option to write a new name for the test in this section (e.g., “Input/Output 40 dB input”)

2) **Stimulus selection:**

- **Start level & Stop level:** Set the start and stop levels expressed in dB SPL using the sliders.
- **Stimulus type:** Select a stimulus using the dropdown list (See stimulus list in section 3.12.1).
- **Continuous:** This check box allows you to make the measurement ongoing rather than a single sweep. This may, however, also be done in the front screen using the continuous button:



When continuous is ticked, the stimulus and recording will continue until you press the STOP button.

- **Preconditioning:** This is relevant when using broadband signals such as ICRA (see section 3.6.4.1 for details). Select a time using the slider.
- **Sweep delays:** This is relevant if *Continuous measurement* is selected for Pure Tone or Warble Tone. In this case sweep delays (in milliseconds) may be entered between the individual sweeps (see section 3.6.4.2 for details).
- **Stimulus Frequency:** Select the frequency of the input stimulus using the slider.
- **Show gain values:** Tick the box to show the Input/Output in dB gain as well as dB SPL.



3) Recording method:

- **Stimulus resolution:** Select the stimulus resolution using the slider.
- **Sweep Speed:** Select the speed using the slider. The sweep speed affects the precision of the knee-point calculation. The slower speed the higher precision. The current speed will be written just above the slider expressed in dB per second.

4) Test settings:

- **Color:** Select a color for the *Right* and *Left* curve. Press each of the buttons to have the custom color selection below. Choose the desired color by clicking on it and press **OK**.

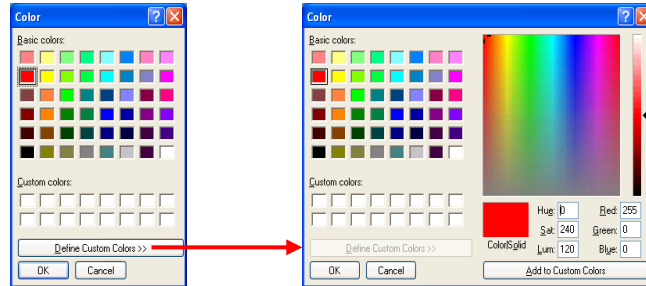

Note the option to *Define Custom Colors* to get a more extensive selection. When having found the exact color, press *Add to Custom Colors*.



3.8.2.5 Intermodulation distortion settings

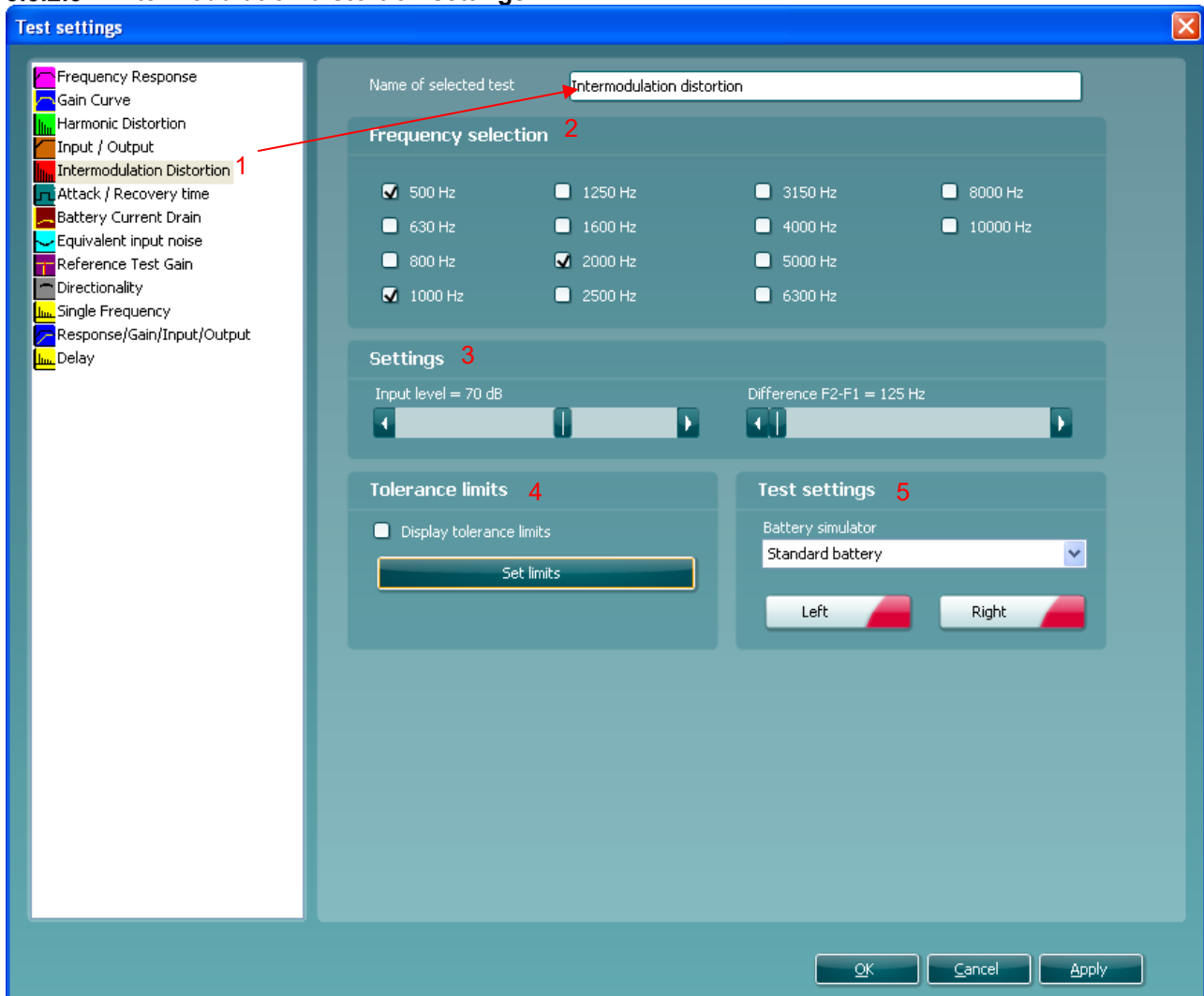

- 1) Ensure that **Intermodulation Distortion** is marked in the left-hand side of the screen. The name of the test will then appear in the *Name of selected test* section. Note the option to write a new name for the test in this section (e.g., “Intermodulation Distortion 500, 1000 & 2000 Hz”).
- 2) **Frequency selection:**
 - *Frequencies:* Select the frequencies to be included in the Intermodulation Distortion measure by ticking the boxes.
- 3) **Settings:**
 - *Input level:* Select the input level (expressed in dB SPL) using the slider.
 - *Difference F2-F1:* Decide the difference between the first two formants (expressed in Hz) using the slider. When the two frequencies are close to each other a coupling (third signal) between them will be greater than if the distance was larger.
- 4) **Tolerance limits:**
 - *Set limits:* Press the button to define individually preferred tolerance limit values. By applying tolerance limits to the recording, it will be possible to easily document whether a curve is inside tolerances or not. In the tolerance limits screen the upper limits may be entered as numerical frequency specific values. Note, however, that this is only possible for the frequencies chosen in the *Frequency selection* see point 2) above. Alternatively, limits may be entered by clicking with the mouse directly on the dots in the co-ordinate system and dragging them to the preferred position
 - *Display Tolerance Limits:* Tick the box to activate the tolerances which will then be shown on the graph in the front screen.



Note: In the General Setup it is possible to set a warning, which will pause the test and prompt the user if a recording falls outside tolerance limits.

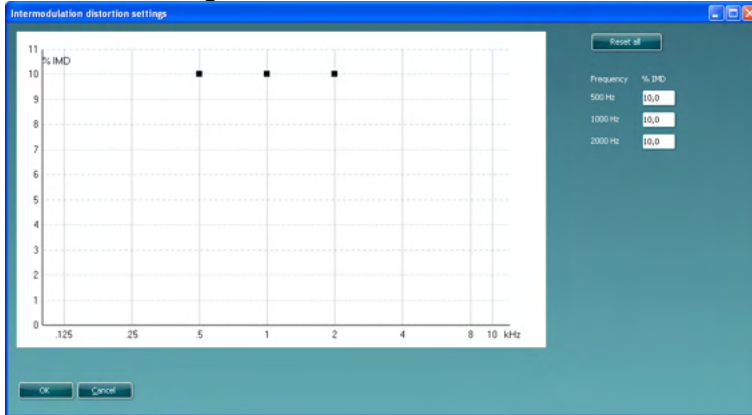

5) **Test settings:**

- **Color:** Select a color for the *Right* and *Left* curve. Press each of the buttons to have the custom color selection below. Choose the desired color by clicking on it and press **OK**.

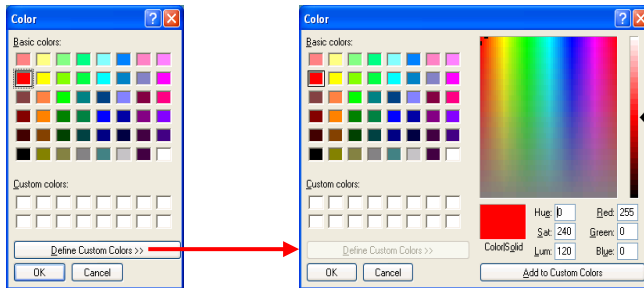

Note the option to *Define Custom Colors* to get a more extensive selection. When having found the exact color, press *Add to Custom Colors*.



3.8.2.6 Attack/recovery time settings

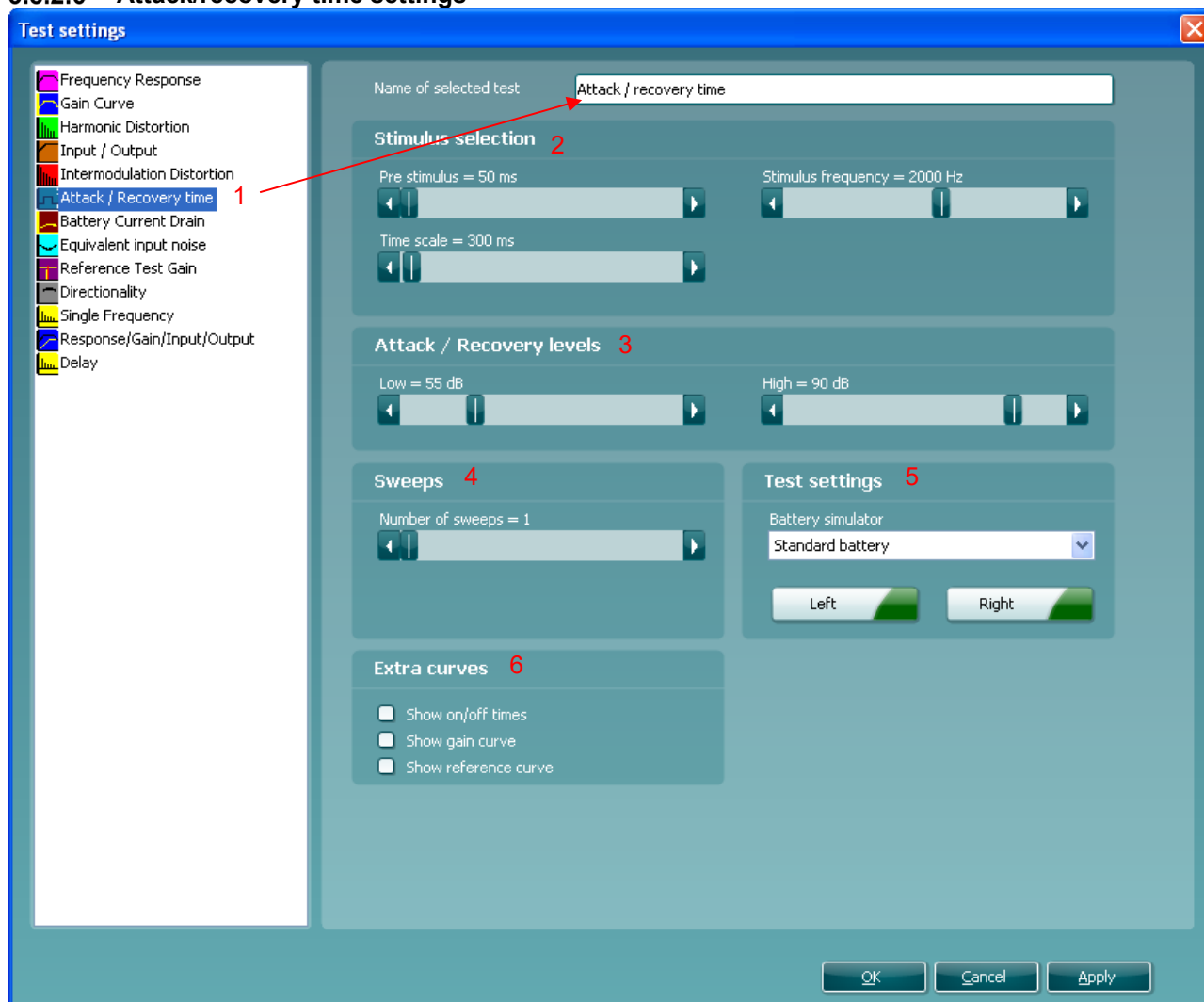

- 1) Ensure that **Attack/Recovery Time** is marked in the left-hand side of the screen. The name of the test will then appear in the *Name of selected test* section. Note the option to write a new name for the test in this section (e.g., “Attack/Recovery low 50, high 90”).
- 2) **Stimulus selection:**
 - *Pre-stimulus:* Set the pre-stimulus time in milliseconds using the corresponding slider. The pre-stimulus sets the low-level stimulus prior to presentation of the higher-level signal which prompts the hearing aid compression to be activated and turn down gain.
 - *Time scale:* Set the time window of the full recording in the *Time scale* slider. This indirectly also sets the duration of the high-level stimulus, which is always 50% of this time window. Example: A 300mS time window setting will provide a test where the high-level stimulus has a duration of 150mS.
 - *Stimulus frequency:* Select the preferred frequency for the Attack/Recovery measure using the slider.

Attack/recovery levels:

- *Low:* Select the low stimulus level to be present at the beginning and the end of the test.
- *High:* Select the high stimulus level to be presented in a time window during the test.

Note: The test reports the output of the hearing aid, which will of course be different from the stimulus levels set here.



3) **Sweeps:**

- **Number of sweeps:** Select several sweeps using the slider. To average out noise which may influence particularly low-level recordings, you may select to do multiple recordings (sweeps) which are then averaged together to reduce noise. Only the averaged curve will be displayed.

4) **Test settings:**

Color: Select a color for the *Right* and *Left* curve.

Press each of the buttons to have the custom color selection below. Choose the desired color by clicking on it and press *OK*.

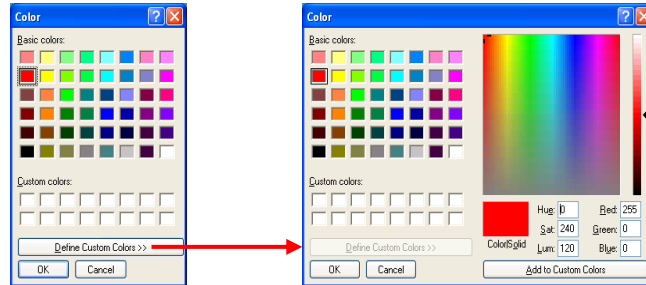

Note the option to *Define Custom Colors* to get a more extensive selection. When having found the exact color, press *Add to Custom Colors*.

5) **Extra curves:**

- **Show on/off times:** Tick the boxes to show two thin lines showing when the level is shifted on the graph.
- **Show gain curve:** Tick the box to show again curve on screen together with the Attack/Recovery curve.
- **Show reference curve:** Tick the box to show a reference curve on the graph. The reference curve shows the level from the reference microphone.



3.8.2.7 Equivalent input noise settings

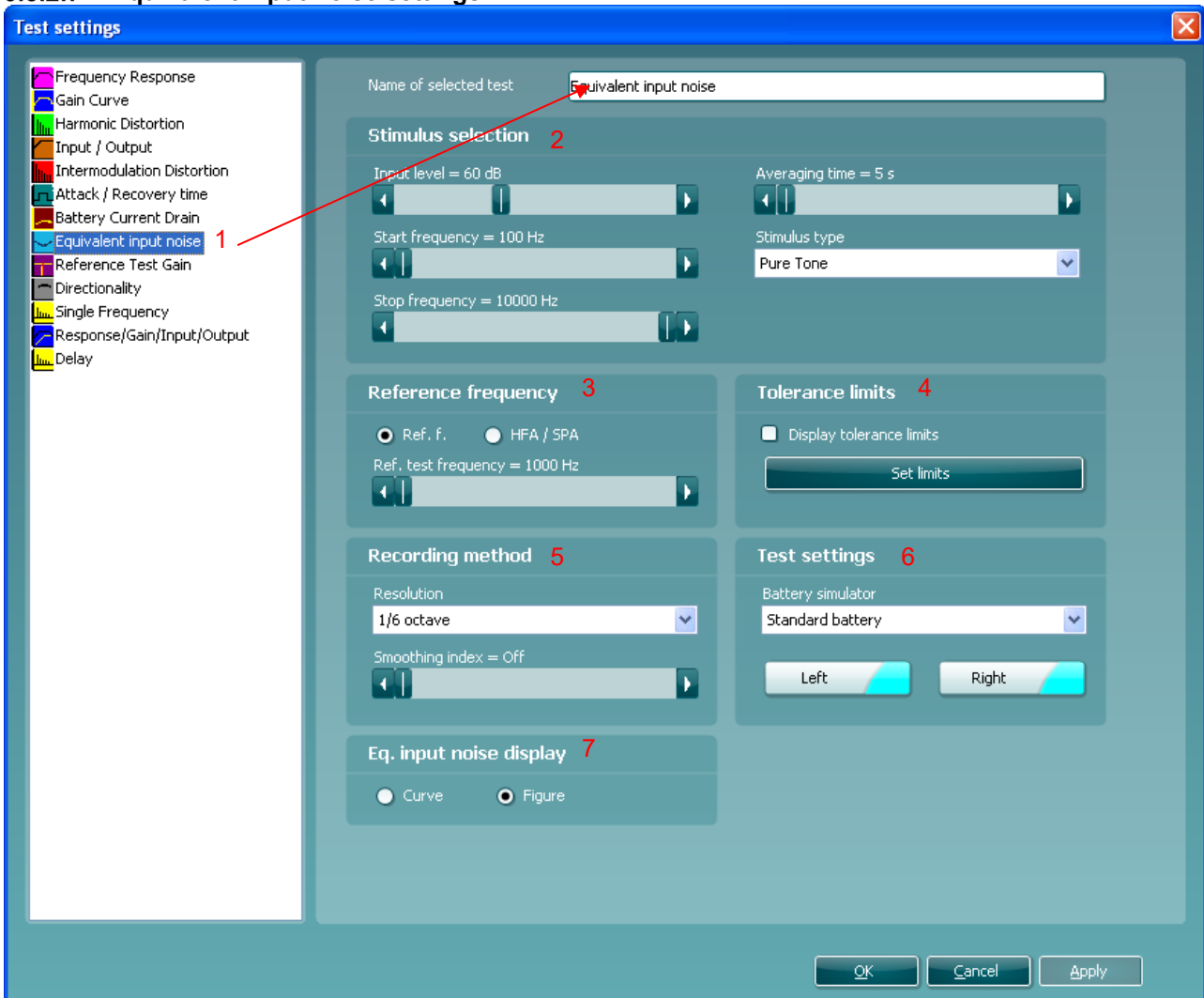

- 1) Ensure that **Equivalent Input Noise** is marked in the left-hand side of the screen. The name of the test will then appear in the *Name of selected test* section. Note the option to write a new name for the test in this section (e.g., “Equiv. Input Noise 60 dB input”).
- 2) **Stimulus selection:**
 - *Input Level:* Set the input level using the slider.
 - *Start Frequency* and *Stop Frequency:* Select the preferred frequencies using the sliders. To avoid low frequency noise set the slider to a start frequency of 200Hz.
 - *Averaging time:* Decide the number of FFTs that shall be used for the averaging of non-linear stimuli like ICRA noise, real speech, or other wave-based stimuli. The longer average the more reproducible test results will be.
 - *Stimulus type:* Select a stimulus using the dropdown list (See stimulus list in section 3.12.1).



3) Reference frequency:

- **Ref f:** Tick this option to select a single reference frequency using the slider. After measuring the curve, the level at the reference frequency will be displayed in the measurement details table.

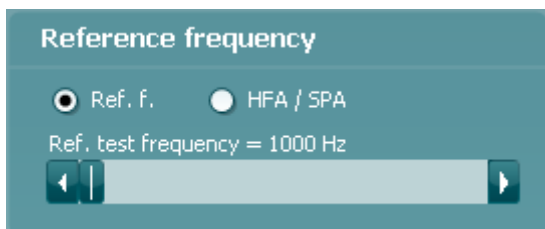

Input Level	70 dB
Max SPL	111,48 dB
Max SPL Frequency	400 Hz
Ref. frequency	1000 Hz
Ref. level	110,4 dB
Curve type	Sweep 1/3 Oct.
Stimulus	Pure Tone
Coupler type	
Battery	Standard battery

- **HFA/SPA:** Tick this option to select three frequencies at a fixed distance using the slider. After measuring the curve, the reference frequency average will be displayed in the in the measurement details table.

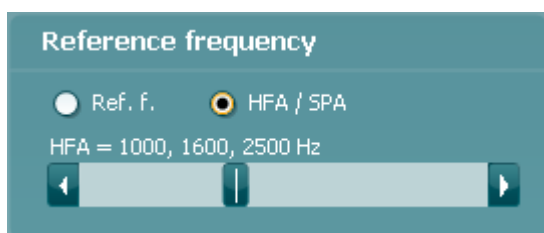

Input Level	70 dB
Max SPL	118,57 dB
Max SPL Frequency	2660 Hz
HFA frequencies	1000, 1600, 2500 Hz
HFA level	117,3 dB
Curve type	Sweep 1/24 Oct.
Stimulus	Pure Tone
Coupler type	
Battery	Standard battery

4) Tolerance limits:

- **Set limits:** Press the button to define individually preferred tolerance limit values. By applying tolerance limits to the recording, it will be possible to easily document whether a curve is inside tolerances or not. In the Tolerance limits screen tolerance limits may be entered as numerical frequency specific values for **Low limit** and **High limit**. Alternatively, Lower Limits and Higher Limits may be entered by clicking with the mouse directly on the dots in the co-ordinate system and dragging them to the preferred position.
- **Display Tolerance Limits:** Tick the box to activate the tolerances which will then be shown on the graph in the front screen.

Note: In the General Setup it is possible to set a warning, which will pause the test and prompt the user if a recording falls outside tolerance limits.

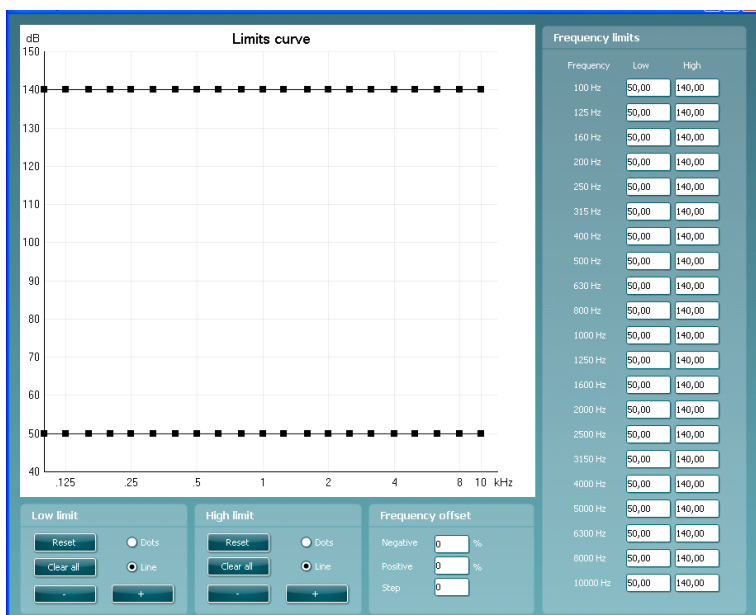

5) **Recording method:**

Resolution (of frequency): Select the preferred resolution in the dropdown. The higher the resolution the slower the measurement.

Keep in mind that 1/3 is what is used in many hearing aid manufacturers software. If the curve is to be compared to this, you may consider choosing this resolution. Also note that when using a broad band signal the dropdown list will change to offer weighting instead.

- *Smoothing Index*: You have the option to smooth the measured curve using the slider (see section 3.6.5 for details). The higher index number selected the more smoothing is applied

6) **Test settings:**

- *Color*: Select a color for the *Right* and *Left* curve.

Press each of the buttons to have the custom color selection below. Choose the desired color by clicking on it and press OK.

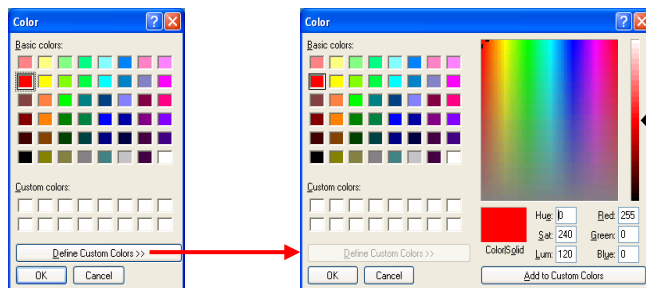

Note the option to *Define Custom Colors* to get a more extensive selection. When having found the exact color, press *Add to Custom Colors*.

7) **Eq input noise display**

- *Curve*: Select this option to see the measurement as a curve.
- *Figure*: Select this option to see the measurement as a figure.



3.8.2.8 Reference test gain settings

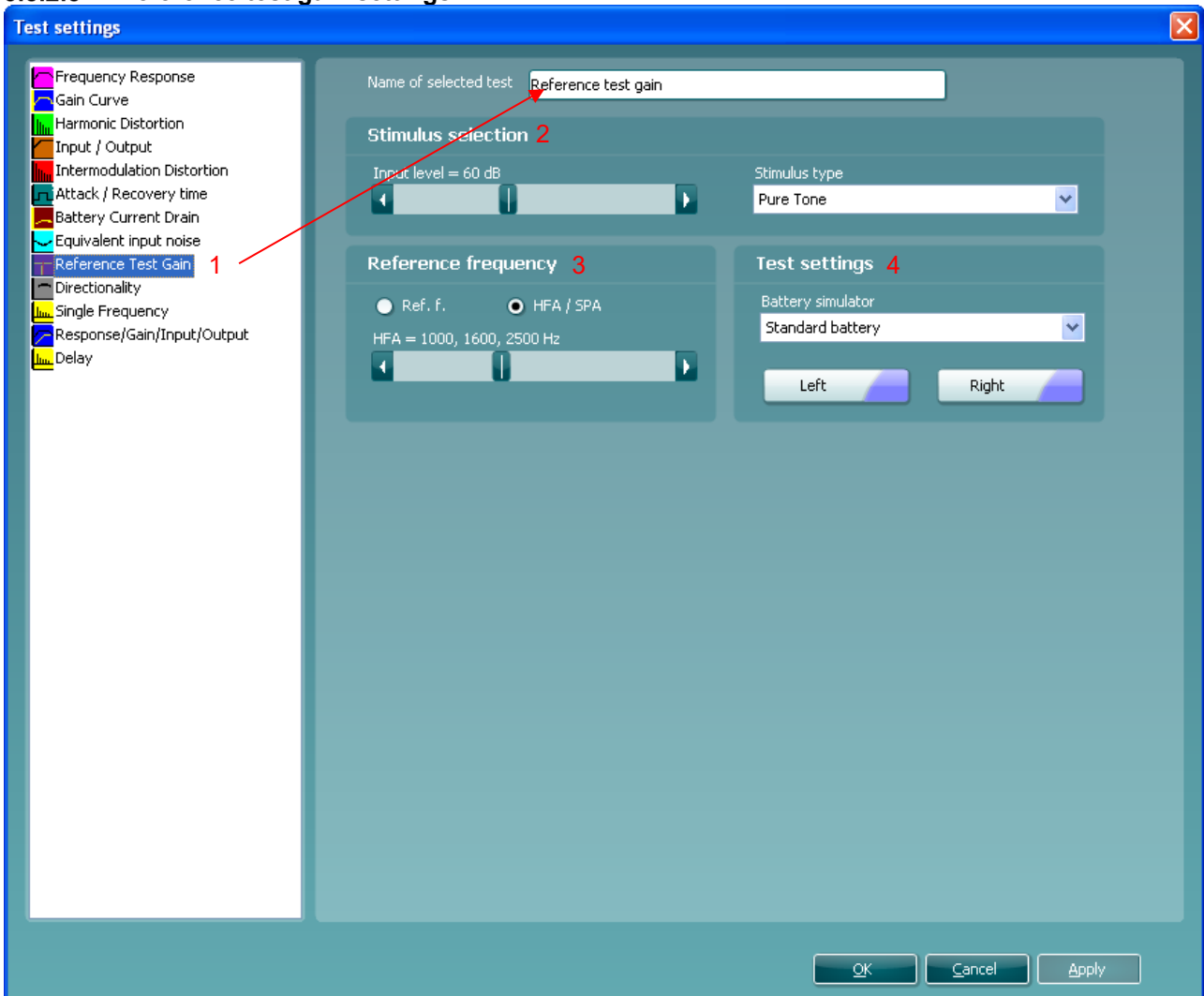

- 1) Ensure that **Reference Test Gain** is marked in the left-hand side of the screen. The name of the test will then appear in the *Name of selected test* section. Note the option to write a new name for the test in this section (e.g., "Equiv. Input Noise 60 dB input")
- 2) **Stimulus selection:**
 - *Input Level:* Set the input level using the slider.
 - *Stimulus type:* Select a stimulus using the dropdown list (Note that only Pure Tone and Warble Tone are available).
- 3) **Reference frequency:**
 - *Ref f:* Tick this option to select a single reference frequency using the slider. After measuring the curve, the level at the reference frequency will be displayed in the measurement details table.

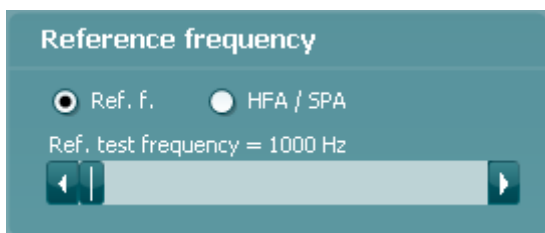

Input Level	70 dB
Max SPL	111,48 dB
Max SPL Frequency	400 Hz
Ref. frequency	1000 Hz
Ref. level	110,4 dB
Curve type	Sweep 1/3 Oct.
Stimulus	Pure Tone
Coupler type	
Battery	Standard battery

- **HFA/SPA:** Tick this option to select three frequencies at a fixed distance using the slider. After measuring the curve, the reference frequency average will be displayed in the in the measurement details table.

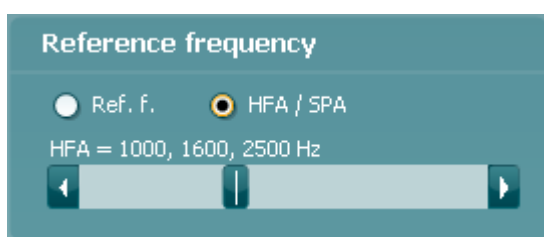

Input Level	70 dB
Max SPL	118,57 dB
Max SPL Frequency	2660 Hz
HFA frequencies	1000, 1600, 2500 Hz
HFA level	117,3 dB
Curve type	Sweep 1/24 Oct.
Stimulus	Pure Tone
Coupler type	
Battery	Standard battery

4) Test settings:

Color: Select a color for the *Right* and *Left* curve.

Press each of the buttons to have the custom color selection below. Choose the desired color by clicking on it and press **OK**.

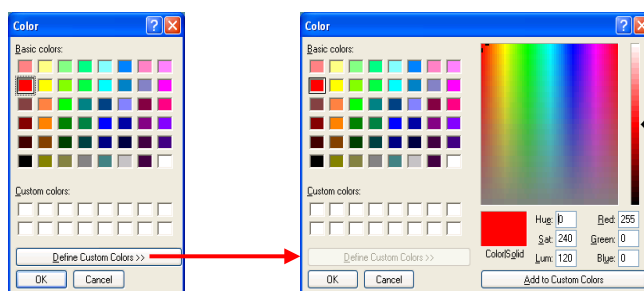

Note the option to *Define Custom Colors* to get a more extensive selection. When having found the exact color, press *Add to Custom Colors*.



3.8.2.9 Directionality settings

Settings for Directionality are identical to the settings described above for Frequency Response with the exceptions listed below. Please refer to section 3.8.2.1 for details regarding the additional test settings.

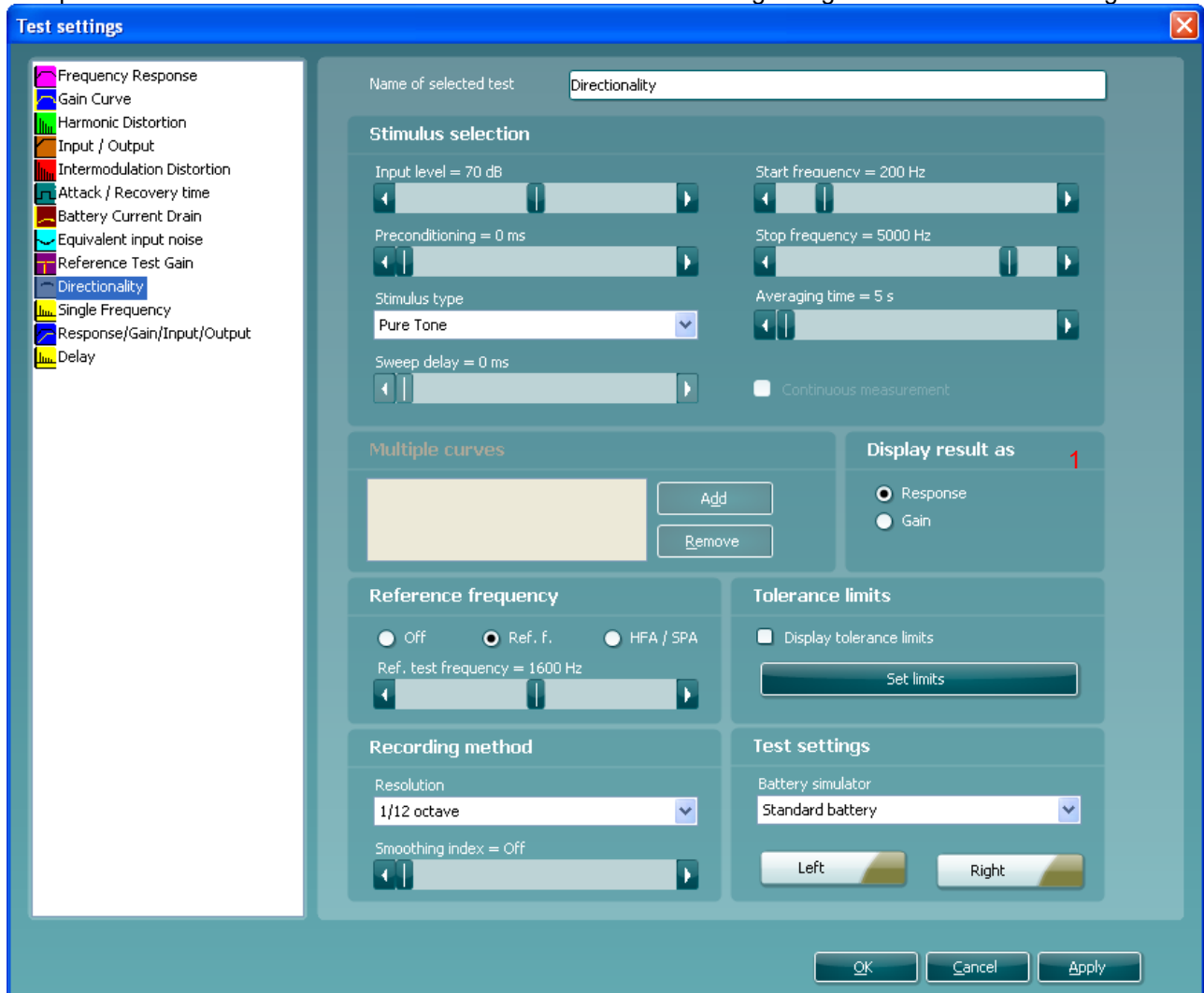

1) **Display result as:**

- *Response*: Tick this option to have the measurement displayed in dB SPL.
- *Gain*: Tick this option to have the measurement displayed in dB gain.

Note: The **Input selection** options, and **Multiple curves** are not available for Directionality.



3.8.2.10 Single frequency settings

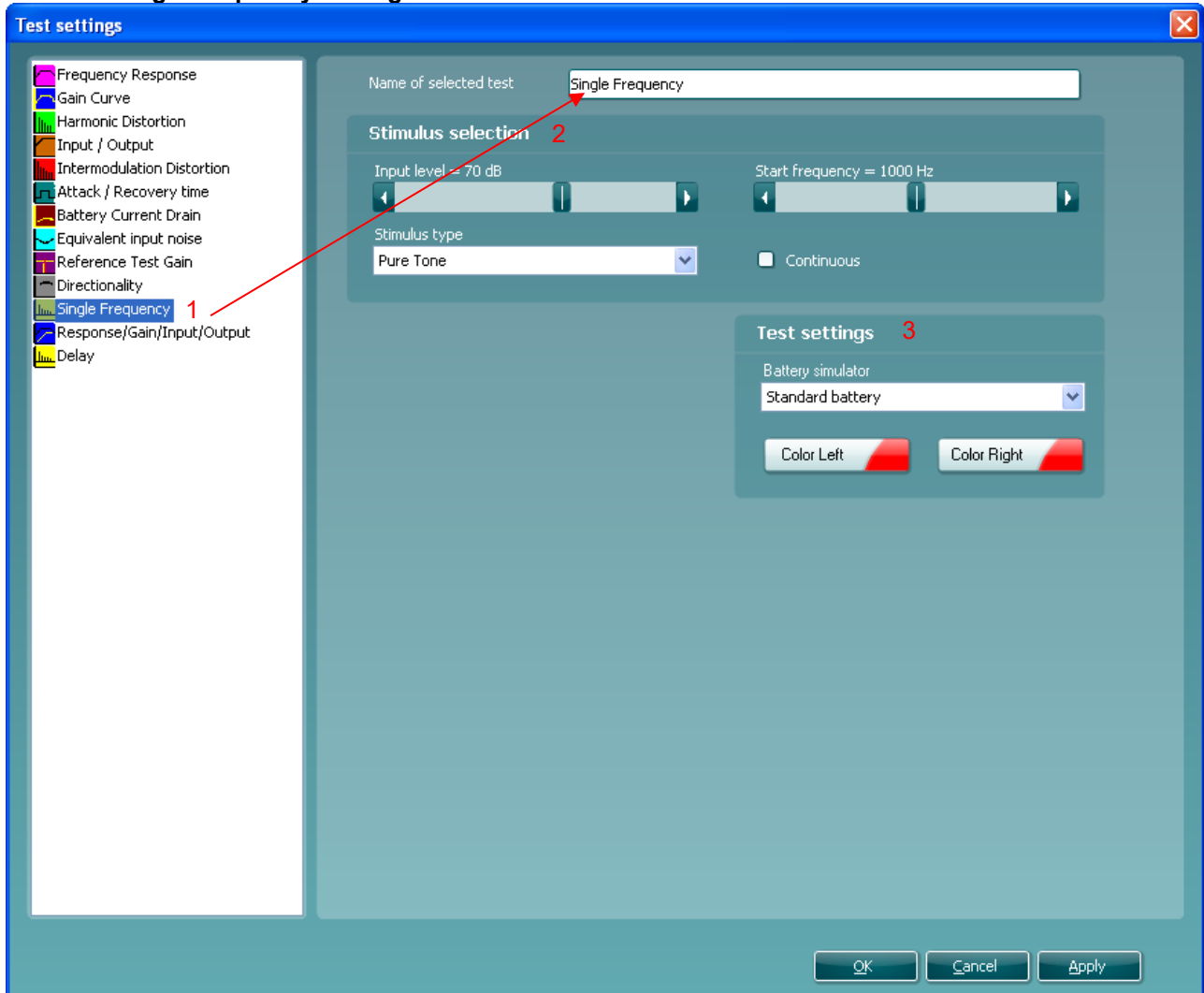

- 1) Ensure that **Single Frequency** is marked in the left-hand side of the screen. The name of the test will then appear in the *Name of selected test* section. Note the option to write a new name for the test in this section (e.g., “Single Frequency 1000 Hz”)
- 2) **Stimulus selection:**
 - *Input Level:* Set the input level using the slider.
 - *Stimulus type:* Select a stimulus using the dropdown list. Note that only Pure Tone and Narrow Band Noise are available.
 - *Start Frequency:* Select the preferred frequency using the slider.
 - *Continuous:* This check box allows you to make the measurement ongoing rather than a single sweep. This may, however, also be done in the front screen using the continuous button:



When continuous is ticked, the stimulus and recording will continue until you press the STOP button.

- 3) **Test settings:**
 - *Color:* Select a color for the *Right* and *Left* curve. Press each of the buttons to have the custom color selection below. Choose the desired color by clicking on it and press OK.

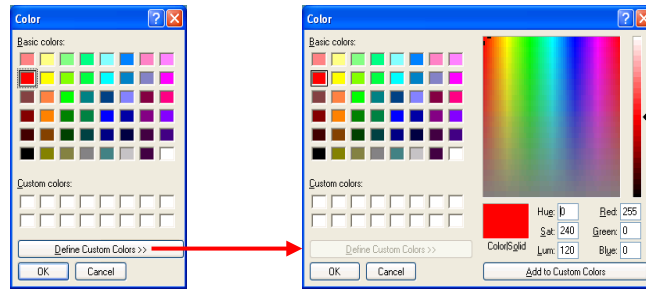

Note the option to *Define Custom Colors* to get a more extensive selection. When having found the exact color, press *Add to Custom Colors*.



3.8.2.11 Response/gain/input/output settings

Settings for Response/Gain/Input/Output are identical to the settings described above for Frequency Response (or Gain Curve) and Input/Output respectively.

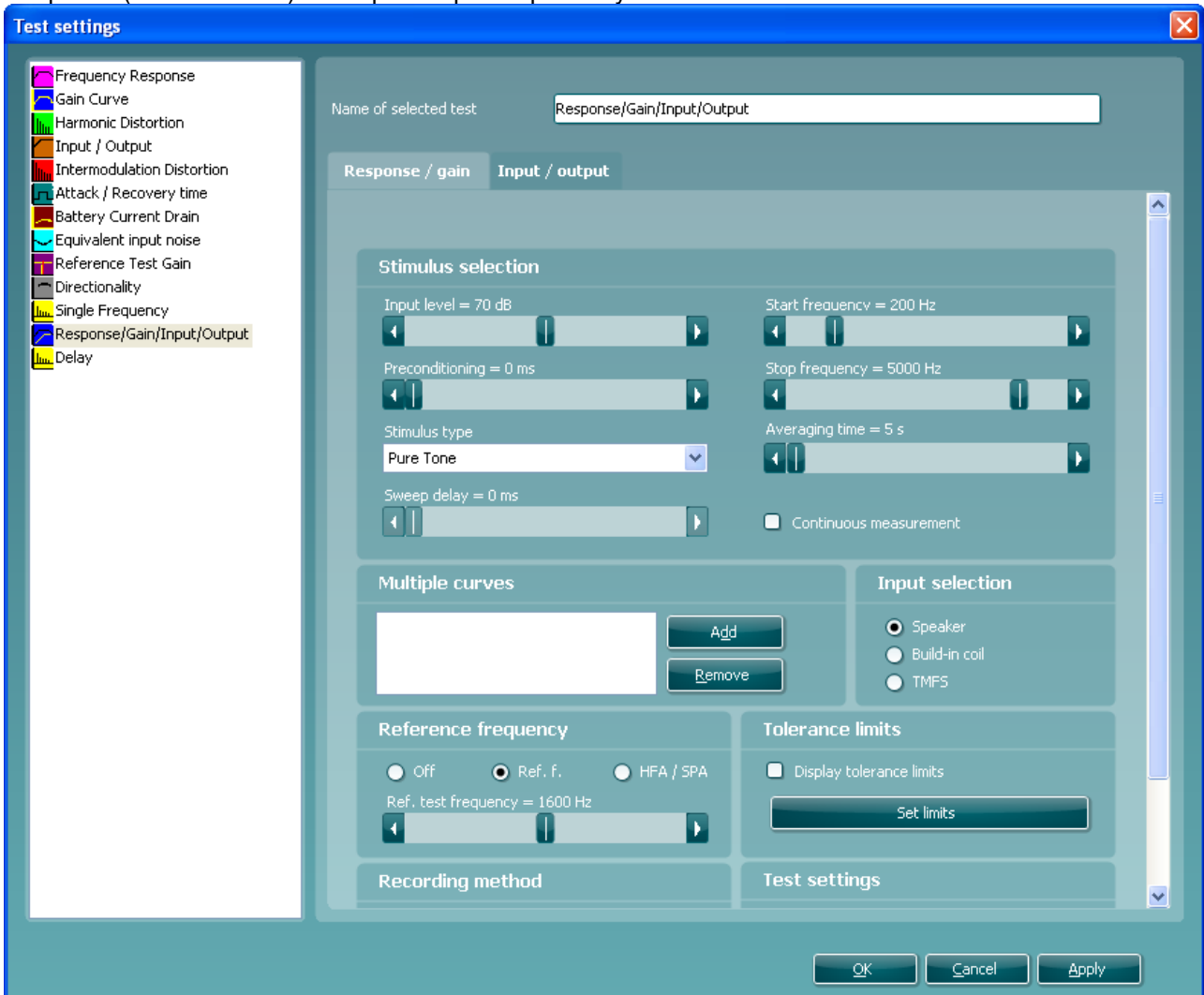

Note: This screen contains two tabs: *Response/gain* and *Input/output*.



3.8.2.12 Delay settings

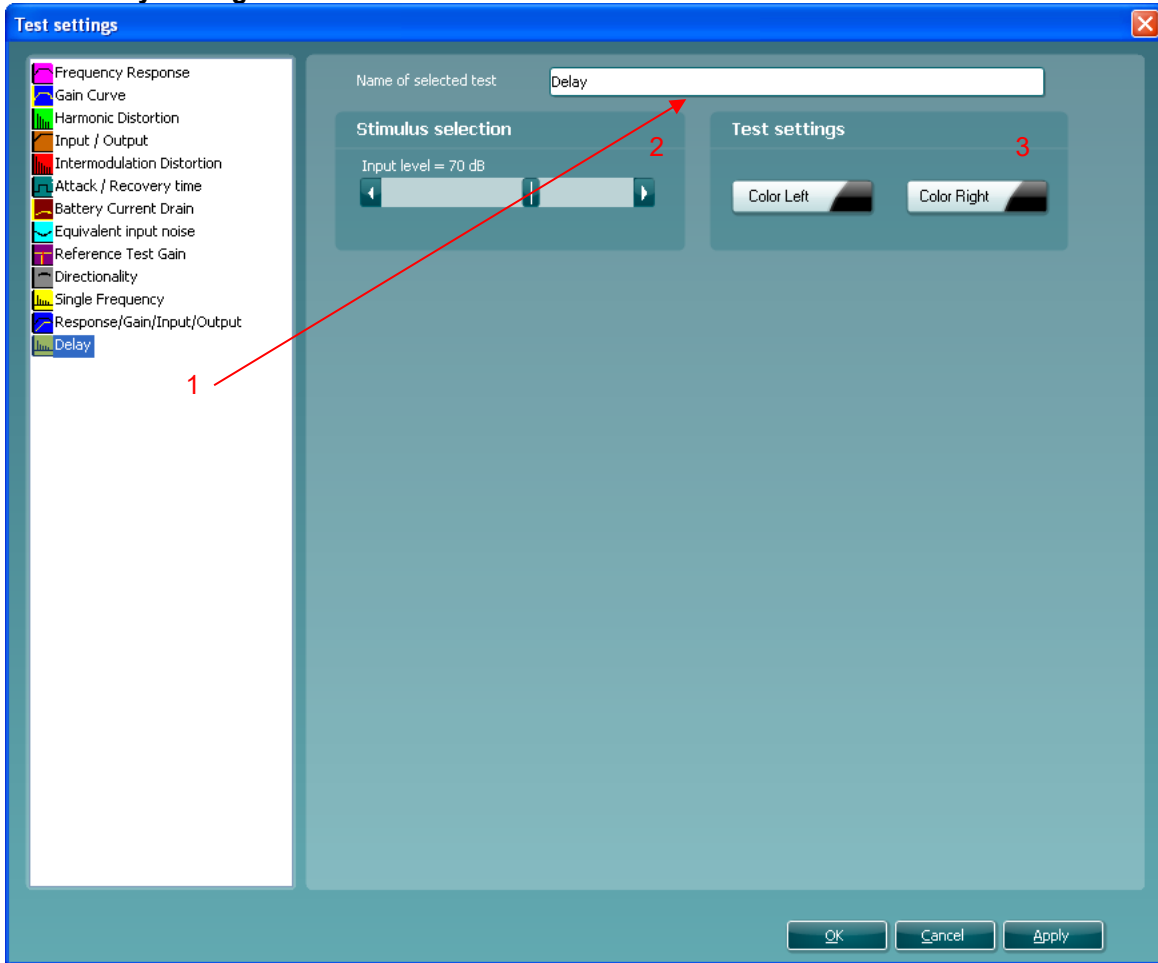

- 1) Ensure that **Delay** is marked in the left-hand side of the screen. The name of the test will then appear in the *Name of selected test* section. Note the option to write a new name for the test in this section (e.g., “Delay 70 dB input”).
- 2) **Stimulus selection:**
 - *Input Level:* Set the input level using the slider.
- 3) **Test settings:**
 - *Color:* Select a color for the *Right* and *Left* curve. Press each of the buttons to have the custom color selection below. Choose the desired color by clicking on it and press **OK**.

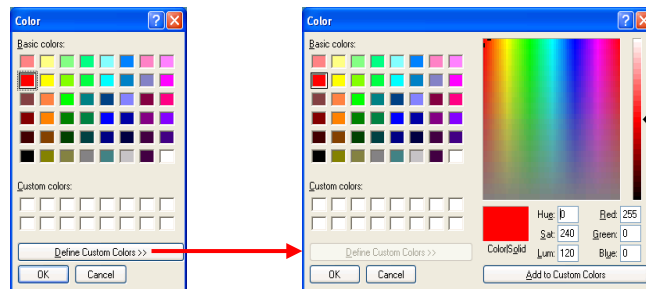

Note the option to *Define Custom Colors* to get a more extensive selection. When having found the exact color, press *Add to Custom Colors*.



3.8.2.13 Pause settings

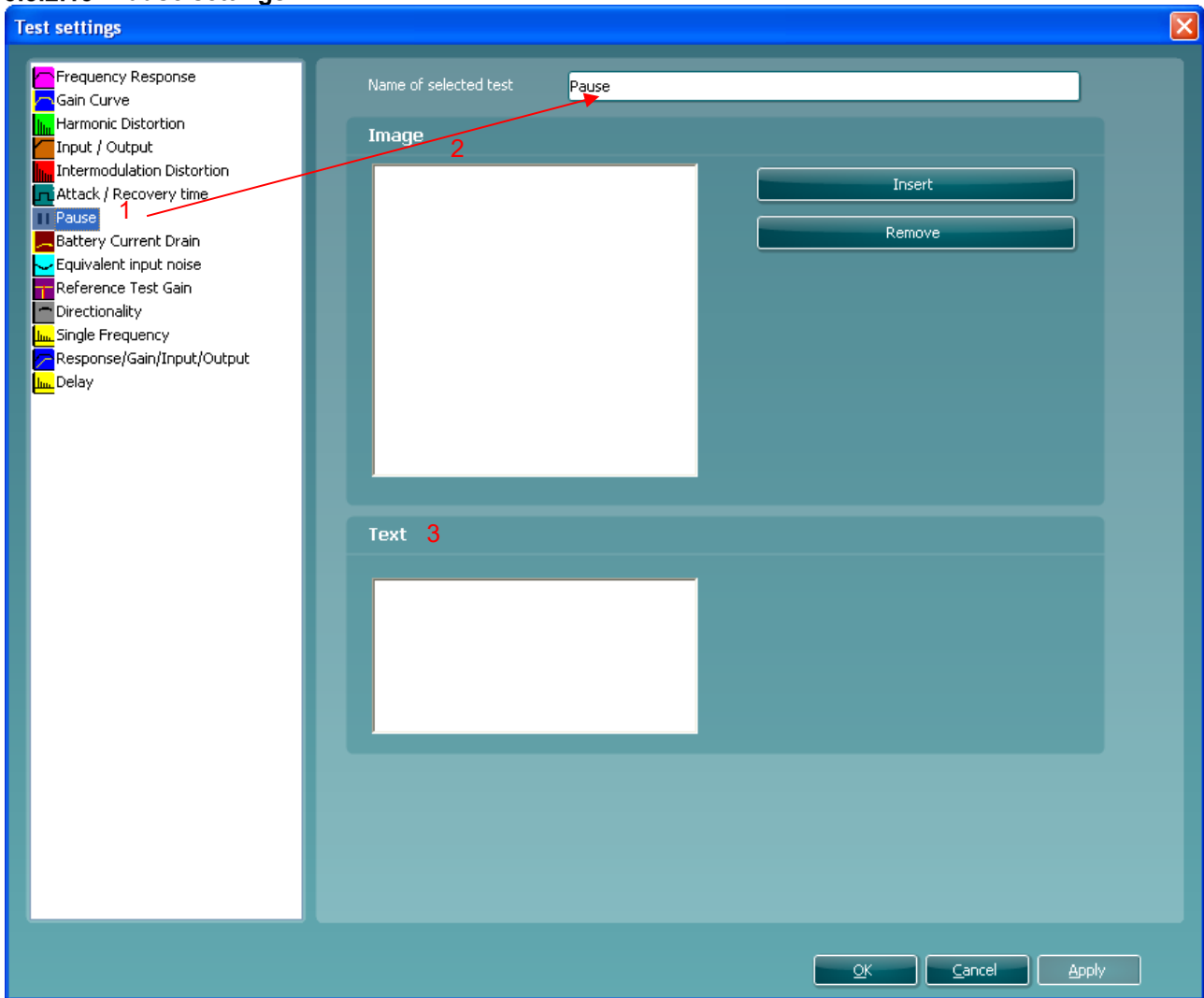

- 1) Ensure that **Pause** is marked in the left-hand side of the screen. The name of the test will then appear in the *Name of selected test* section. Note the option to write a new name for the test in this section (e.g., “Check Volume Control Setting”).
- 2) **Image:**
 - *Insert:* Press the Insert button to browse for the desired picture to be used to the instruction or reminder which will appear during the pause.
 - *Remove:* Press the Remove button to delete a selected picture.
- 3) **Text:**
 - Enter an instruction or reminder text which is to appear during the pause.



3.8.3 Combined screen setup

HIT440 can be setup for default curve comparisons. This is done in the *Setup combined screen* menu.

- 1) To enter the *Setup combined screen* menu, select your test protocol in the *Selected protocol* dropdown list in the main setup.
- 2) Click on the *Setup combined screen* button.

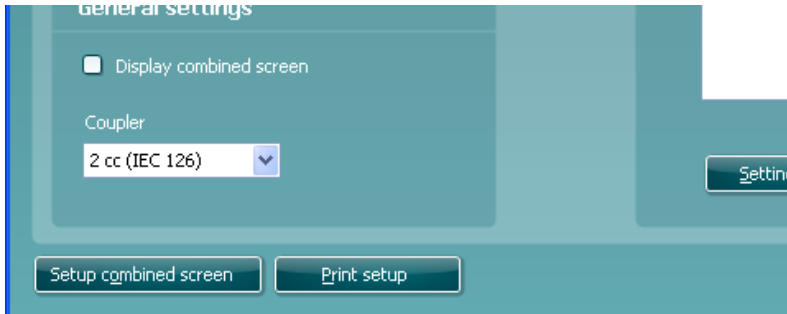

This will prompt the combined screen setup below:

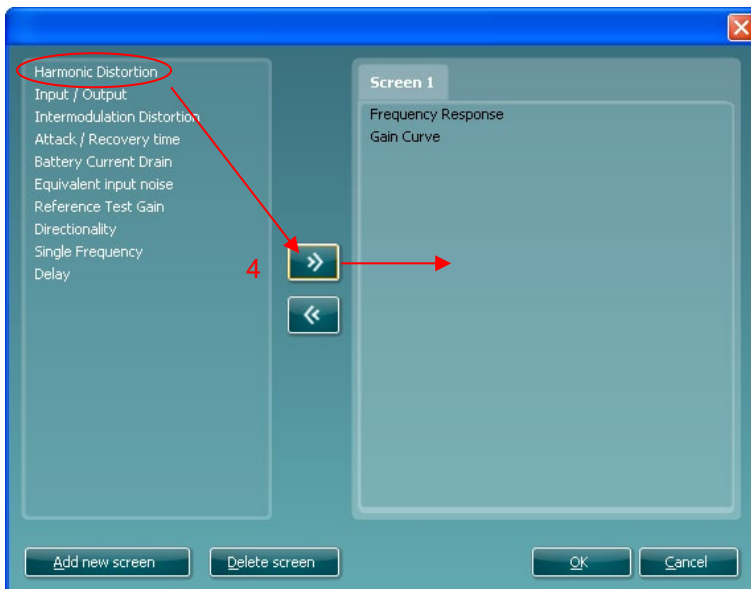

- 3) To create a default curve comparison view, click on *Add new screen*. A tab will then appear in the upper part of the screen.
- 4) Use the arrows to move the measurements to be compared (listed to left) to the new screen. If preferred, you can add several new comparison screens.
- 5) When finished click **OK** to return to the main setup.

Note: Before closing the setup remember to tick the *Display combined screen* check box for the combined screen settings to be active.

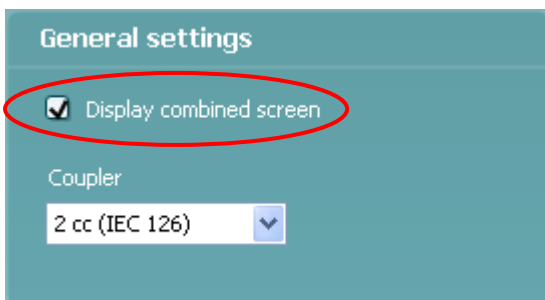



When a combined screen view is setup, you can click on the *Toggle between single and combined screen* button in the front screen to view the desired curves together:



If no combined screen view is setup *Toggle between single and combined screen* will show all measured curves.

3.8.4 Print layout settings

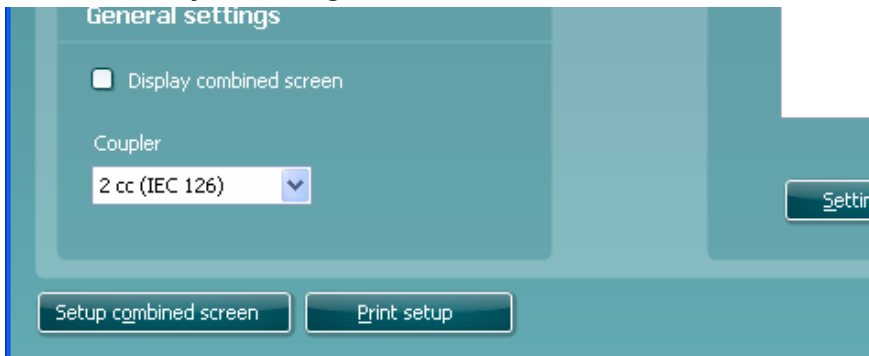

The HIT440 module allows for setting up individual print layouts. This is done in the Print Wizard which is entered using the Print Wizard button.



3.8.5 Finishing the test protocol

Press **OK** in the lower right-hand corner of the HIT440 setup screen to save the customized test protocol. The test protocol can then be found in the **List of Protocols** dropdown list on the front screen.

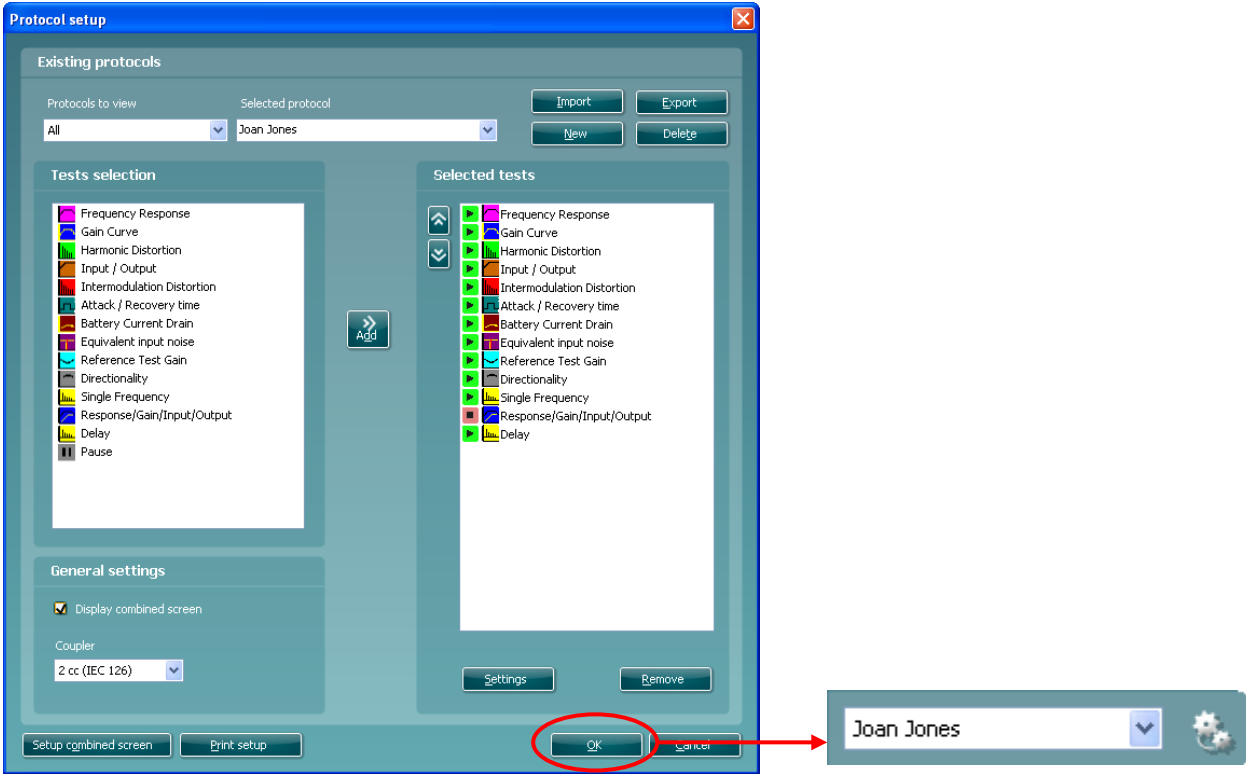



3.8.6 Changing a test protocol permanently

You can at any time make changes to an individual test protocol by entering the HIT440 setup again as when creating the test (**Menu/Setup/HIT440 setup**).

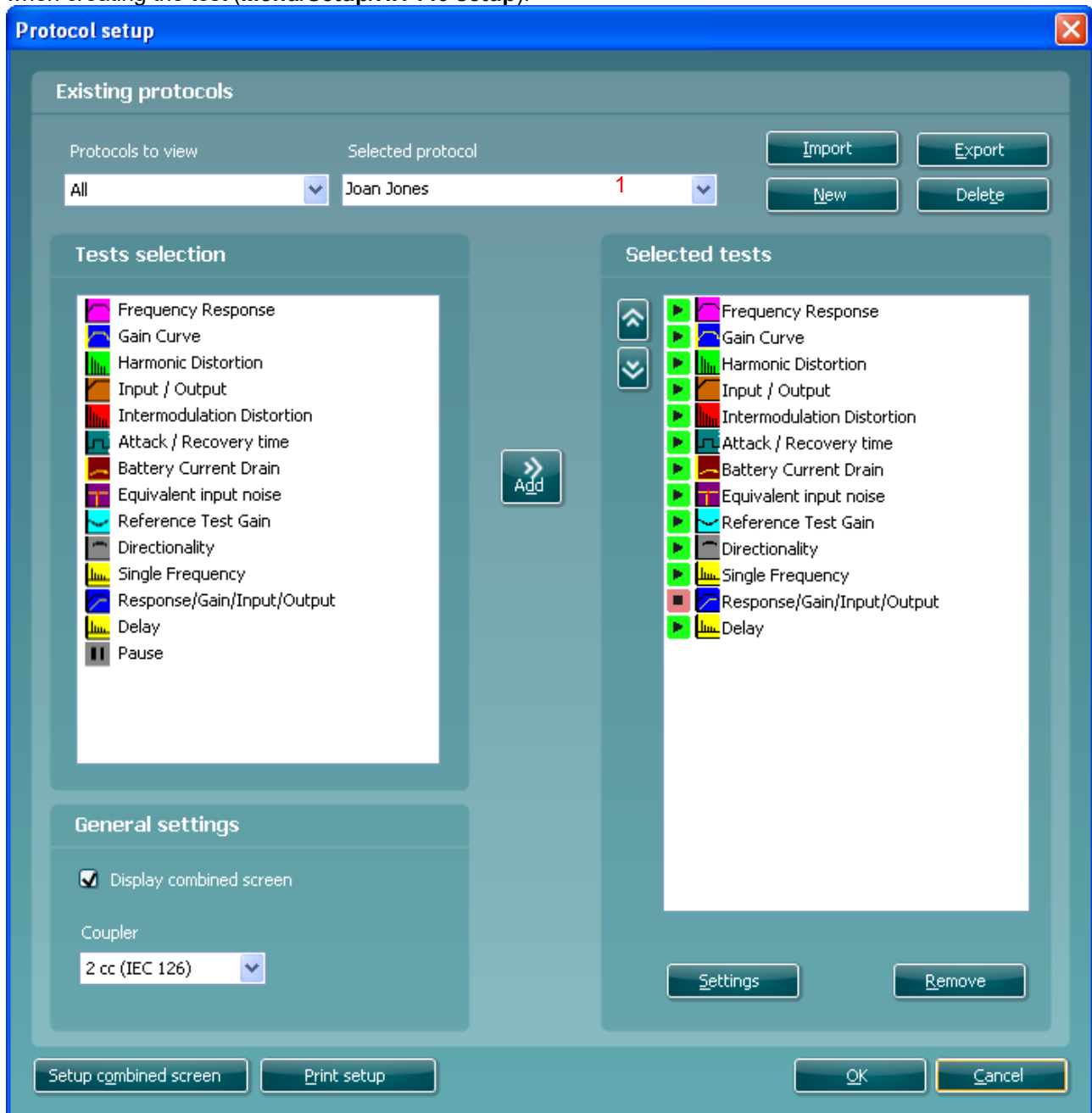

- 1) Choose your test protocol in the *Selected protocol* dropdown list.
- 2) Browse the setup options as if creating a test protocol (see section 3.8.2) and amend as desired.
- 3) When finished click **OK** to save the changes.



3.8.7 Changing a test protocol temporarily

You may from time to time run into a client with special needs requiring advanced or different testing parameters. In this situation the *Temporary Setup* can be helpful. The setup changes made here will be specific to the session. The test protocol name will be supplemented with an asterisk (*) to indicate that changes have been made to original test protocol. After saving, the protocol will change back to the default selected protocol making you ready for your next client.



- 1) Enter the *Temporary Setup* by clicking the button in the front screen  (or alternatively select **Menu/Setup/Temporary setup**).

3.8.7.1 Importing and exporting test protocols

The HIT440 also allows you to import and export test protocols to other HIT440 users.

3.8.7.2 Importing a test protocol

- 1) Go to HIT440 Setup (**Menu/Setup/HIT440 setup**)

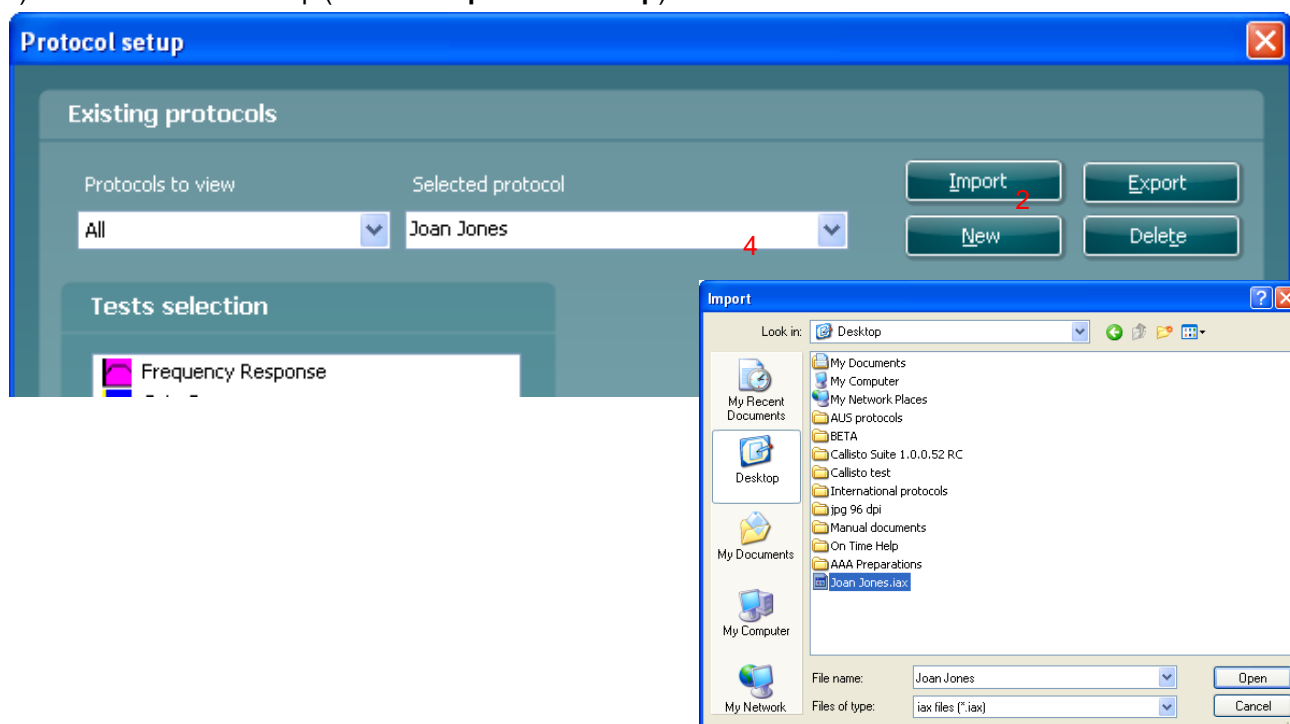

- 2) Click **Import** and browse to the location on the PC or USB where the test protocol file has been saved.
- 3) Click **Open**.
- 4) The test protocol will then appear under **Selected Protocol**.
- 5) After saving it by clicking **OK** the test protocol can be selected in the **List of Protocols** on the front screen.



3.8.7.3 Exporting a test protocol

- 1) Go to HIT440 setup (**Menu/Setup/HIT440 setup**)

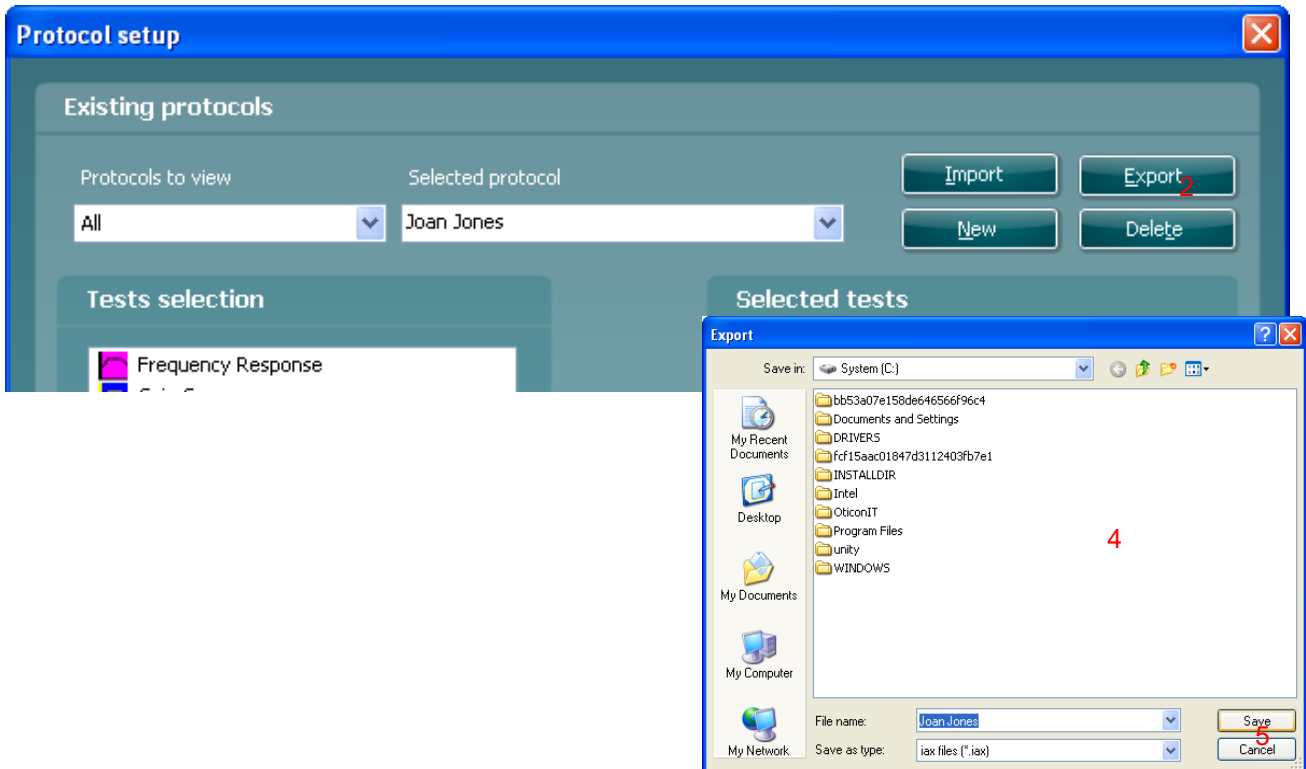

- 2) Click on **Export**.
- 3) Select if the file is to be saved as “Read Only”. In this case the test protocol file is locked and the clinician receiving it will not be able to make changes to it.
- 4) Browse for the location on the PC or USB where the test protocol is to be placed.
- 5) Click **Save**. Other HIT440 users will then be able to upload the test protocol using the Import function.

Note: Some available tests are *Read Only* tests. This means that they can be imported and used, but the parameters cannot be permanently changed. This is to ensure that specialized tests created by e.g., Hearing Aid Manufacturers for special application purposes are used as intended for greatly improved test control. An imported Read Only test protocol will have all its setup points dimmed, as no change of parameters is allowed in such a test.

Even though Read Only tests cannot be permanently modified at all, you can create another test with another name based on the Read Only test. You can just select the read only test in *Selected Protocol* before selecting *New*. Then all characteristics of the Read Only test will present for your new test. In this new test you can modify all parameters – including the Print Wizard.



3.9 General setup

In the *General Setup* you can select overall settings which are valid for all tests.

The screenshot shows the 'General settings' dialog box with the following sections and callouts:

- 1 Custom defined batteries**: Includes fields for 'Battery name' (dropdown), 'Voltage', and 'Impedance', with 'New / Update' and 'Remove' buttons.
- 2 Sound file folder**: Includes a text field for 'Select a custom sound file folder:' and a browse button ('...').
- 3 Warble adjustment**: Includes two sliders: 'Modulation rate = 25 Hz' and 'Frequency deviation = +/- 3,00 %'.
- 4 Ref. and coupler**: Includes radio buttons for 'Normal' and 'B_K type'.
- 5 Test box**: Includes radio buttons for 'FF2 (TBS10)' and 'FF1'.
- 6 Environmental noise**: Includes a checkbox for 'Show warning'.
- 7 Outside limits**: Includes a checkbox for 'Show warning'.
- 8 Auto color**: Includes checkboxes for 'Use autocolor' and 'Show detailed gridlines'.
- 9 Launch via IMC server**: Includes a checkbox for 'Set HIT440 as active module'.
- 10 Show hide icons**: A checkbox at the bottom left.

Buttons at the bottom include 'Show hide icons', 'OK', and 'Cancel'.

To enter the General setup, select **Menu/Setup/General Setup**



- 1) **Sound file folder:**
 - If you prefer to use a stimulus not found in the HIT440 stimulus selection you can use other sound files saved on your PC via the Sound File Folder. Press the button to browse for the files on the PC. Note that the files need to be in .wav format, have a sample frequency of 44100 Hz, and a resolution of 16 bit. Both mono and stereo files can be used.
- 2) **Warble adjustment:**
 - *Modulation Rate:* Select a modulation rate for Warble Tone stimuli (in Hz) using the slider.
 - *Frequency Deviation:* Select a frequency deviation for Warble Tone stimuli (in %) using the slider.
- 3) **Ref and coupler:**
 - Specify which reference microphone and couplers are used. If using the ones provided by Interacoustics tick *Normal* and if using Brüel & Kjær tick *B_K type*.
- 4) **Test box:**

Select the preferred test box:

 - *FF2 (TBS10):* This option refers to the TBS10 when connected to the FF cable when a loudspeaker is also connected.
 - *FF1:* This option refers to TBS10 being directly connected to the FF output
- 5) **Environmental noise**
 - *Show warning:* Ticking this option will prompt the software to show a warning screen if the ambient noise in the environment reaches a level which can affect the measurement.
- 6) **Outside limits:**
 - Tick this option to show a warning when curves are outside tolerance limits. This is, however, only relevant if the professional has setup tolerance limits for the individual tests in the HIT440.
- 7) **Auto color:**
 - *Auto color:* Tick this option to have the system automatically pick a new color for each measured curve.
 - *Show detailed gridlines:* Tick this option to have detailed gridlines on the graph as illustrated below:

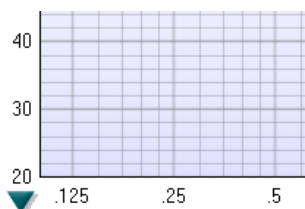

- 8) **Launch via IMC serve** insert a checkmark in this box to enable the HIT module to be launched from another module, such as a hearing aid manufacturer's software



- 9) **Show/hide icons button:** Press the button to customize the test screen. Use the tick boxes to decide which buttons and dropdown lists should be available from the front screen.

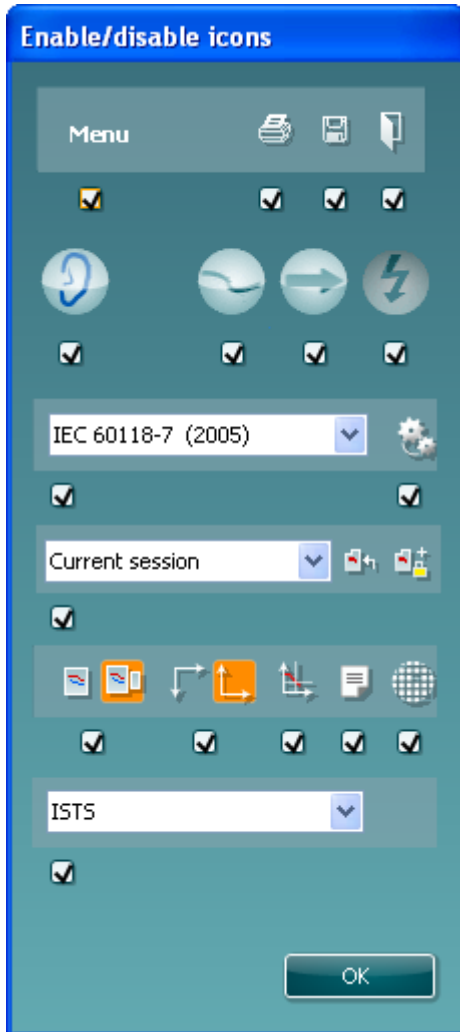



3.10 The HIT440 menu items

The HIT440 Menu gives you access to **File, Edit, View, Mode, Setup, and Help.**

1) Menu/Print

- **Menu/Print/Print** will prompt the system to print using the selected print template (see section **Error! Reference source not found.**).
- **Menu/Print/Print Preview** prompts a print preview of the current test protocol using the print template which is linked to the current protocol. Note that you are prompted to select a template if the protocol did not include a template (see how to create a print layout in section 4.1.1).
- **Menu//Print/Print Layout** opens the print wizard window from where you can select or create a template to print the current test protocol (see section for details regarding the Print Wizard).

2) Menu/Edit/Export

- **Menu/Edit/Export** will prompt the system to export the session as an XML formatted file.

3) Menu/View

- **Menu/view/Save window position** will save the current position of the HIT440 window on the PC screen so that it opens at this exact position every time. This is for example practical if you are usually running and viewing other software modules (such as fitting software) at the same time. Using this function for moving and/or resizing of the HIT440 will only be necessary once.

4) Menu/Mode

- **Menu/Mode/Single measurement** will set the system to present the selected stimulus as a single sweep.
- **Menu/Mode/Continuous measurement** will set the system to present the selected stimulus continuously.
- **Menu/Mode/Single frequency mode** will set the system to perform the test at a single frequency.
- **Menu/Mode/Endless loop** will set the system to perform the tests of the test protocol continuously until tolerance limits specified in the setup are overstepped.

Menu/Setup

- **Menu/Setup/HIT440 setup** opens the HIT440 where you can setup customised test protocols (see section 3.8.2 for details)
- **Menu/Setup/General setup** opens the General setup where settings valid for all tests can be selected (see section 3.9 for details).
- **Menu/Setup/Temporary setup** opens the Temporary setup where temporary settings for the specific session can be selected (see section 3.8.7 for details)
- **Menu/Setup/Password protection** allows you create or change a password and thereby protect your HIT440 settings. Press *Change password* and type in the preferred password. Then press OK. Note that your password needs to be activated in *Protected settings* under Menu/setup/General setup (see section 3.9).

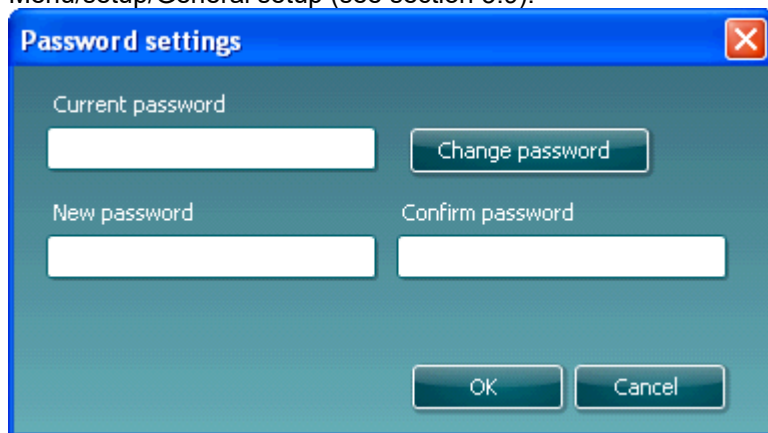

- **Menu Setup/Show/hide protocols** prompts a screen allowing you to tick test protocols which are to be shown in the *List of Protocols* and untick the test protocols which are to be hidden.



- **Menu/Setup/Language** opens the language selection. Choose from *English, German, Spanish, French, Italian, Japanese, Portuguese, and Chinese (People's Republic of China)*. The system must be restarted for a new language selection to take effect.
- **Menu/Setup/General Suite** Settings launches a screen where the user can choose which module should start up, the examiner options and the choice to change the language. Please note that changing something in this screen will affect all active modules, not just the HIT module.

5) **Menu/Help**

- **Menu/Help/About HIT440** prompts a message box showing information regarding the *Suite version, Hardware version, and Firmware version*. Please note that if experiencing problems with the system this information should be sent to the manufacturer along with the description of the issue. (Your instruments serial number will also be required).
Note: Press **License** to be able to type in a new license code.



3.11 HIT440 software - technical specifications

Medical CE-mark	The CE-mark indicates that Interacoustics A/S meets the requirements of Annex II of the Medical Device Directive 93/42/EEC. Approval of the quality system is made by TÜV – identification no. 0123.	
Hearing Aid Analyzer Standards	IEC 60118-0, IEC 60118-7, ANSI S3.22.	
Frequency Range	100-10000Hz.	
Frequency Resolution	1/3, 1/6, 1/12 and 1/24 octave or 1024-point FFT.	
Frequency Accuracy	< ± 1 %	
Stimuli	Warble tone Pure tone Narrow band noise Random noise Pseudo random noise Pink noise White noise band limited Speech noise Chirp	ISTS ICRA Real speech IFFM IF Noise /SS/ /SH/ Custom sound files (automatic calibration available)
Sweep Speed	1,5 – 80 sec.	
FFT	Resolution 1024-points. Averaging: 10 – 500.	
Stimuli intensity range	40-100 dB SPL in 1 dB step.	
Intensity accuracy	< ± 1.5 dB	
Measurement Intensity Range:	Probe microphone 40-145 dB SPL ± 2 dB.	
Stimulus Distortion:	< 1 % THD.	
Available tests:	Additional tests can be designed by user	
	OSPL90 Full On Gain Input/output Attack/Recovery Time Reference Test Gain Frequency Response Equivalent Input Noise	Harmonic Distortion Intermodulation Distortion Microphone Directionality
Pre-Programmed Protocols:	HIT440 software comes with a set of Test Protocols loaded. Additional Test Protocols can be designed by user, or easily imported into the system.	
Compatible Software:	Noah 4, OtoAccess® and XML compatible	



3.12 Appendix 1

3.12.1 The HIT440 test signal characteristics

Pure Tone frequency accuracy is $\pm 1\%$. Crest factor is 3 dB.

Warble Tone frequency accuracy is $\pm 1\%$, warble frequency 0→100 Hz and intensity 0→10%, sine wave frequency modulation. Crest factor is 3 dB.

Random Noise is a noise with a linear spectrum measured with an FFT or a 3 dB drop per octave measured with a 1/3 octave filter.

Pseudo random noise is a semi-broad-band noise produced from random noise weighted with a 2nd order 200 Hz high pass filter and a 1st order 900 Hz low pass filter as described in the ANSI S3.42 -1992 standard. Crest factor is 10 dB.

Chirp is a linear frequency sweep from 100 to 10 kHz in 23 mS = one FFT measuring. The amplitude is constant during the sweep. Crest factor = 3 dB.

Band limited white noise is a random noise signal band limited by 12 kHz 2. order low pass filter. Crest factor is 9 dB.

PinkNoise is a noise with a linear spectrum measured with a 1/3 octave filter or a 3 dB rise per octave measured with an FFT.

ICRA Noise:

ICRA: urgnmn

Unmodulated random Gaussian noise - Male weighted - Normal effort - Level Ref. Crest factor = 13 dB.

ICRA: urgnmr

Unmodulated random Gaussian noise - Male weighted - Raised effort - Level Ref+5.7dB. Crest factor = 14 dB.

ICRA: urgnml

Unmodulated random Gaussian noise - Male weighted - Loud effort - Level Ref+12.1 dB. Crest factor = 14 dB.

ICRA: 3bsmfn

3 Band speech modulated noise (3bSMN) - Female weighted - Normal effort - Level Ref. Crest factor = 27 dB.

ICRA: 3bsmmn

3 Band speech modulated noise (3bSMN) - Male weighted - Normal effort - Level Ref. Crest factor = 27 dB.

ICRA: 2pb1f1mn

2 persons babble, 1female 3bSMN + 1 male 2bSMN - Idealized - Normal effort - Level Ref + 3dB. Crest factor = 24 dB.

ICRA: 6pbn

6 persons babble, 1f+1m+2f(-6db)+2m(-6dB), all 3bSMN - Idealized - Normal effort - Level Ref + 4.7dB. Crest factor = 23 dB.

ICRA: 6pbr

6 persons babble, 1f+1m+2f(-6db)+2m(-6dB), all 3bSMN - Idealized - Raised effort - Level Ref + 10.7dB. Crest factor = 24 dB.

ICRA: 6pbl

6 persons babble, 1f+1m+2f(-6db)+2m(-6dB), all 3bSMN - Idealized - Loud effort - Level Ref + 17.2dB. Crest factor = 25 dB.

Speech Dialog Crest factor = 24 dB.

Speech Female Crest factor = 20 dB.

Speech Male Crest factor = 25 dB.

Sound File this crest factor is not known.



3.13 Appendix 2:

3.13.1 Connecting the TBS10 to Callisto™

The following items are included with the TBS10 on purchase:

- 1) TBS10
- 2) TBS10 Multi-Connection Cable

The cable connectors are plugged into the Callisto™ 2.0 as shown in **Error! Reference source not found.** See assigned numbering for which these connect.





When you want to connect a TBS10 in addition to a FF loudspeaker you should plug wire 1 of the multi-connection cables into the FF2 jack of the FF Y-cable. When you choose this method, please ensure you are correctly configuring your software within the general setup to allow this to function correctly.

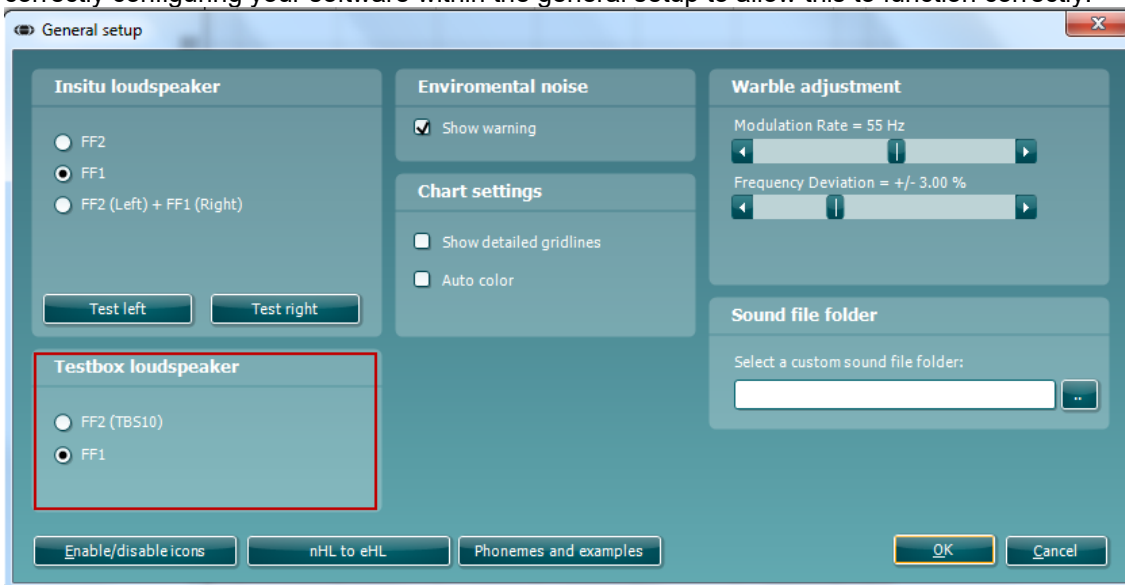

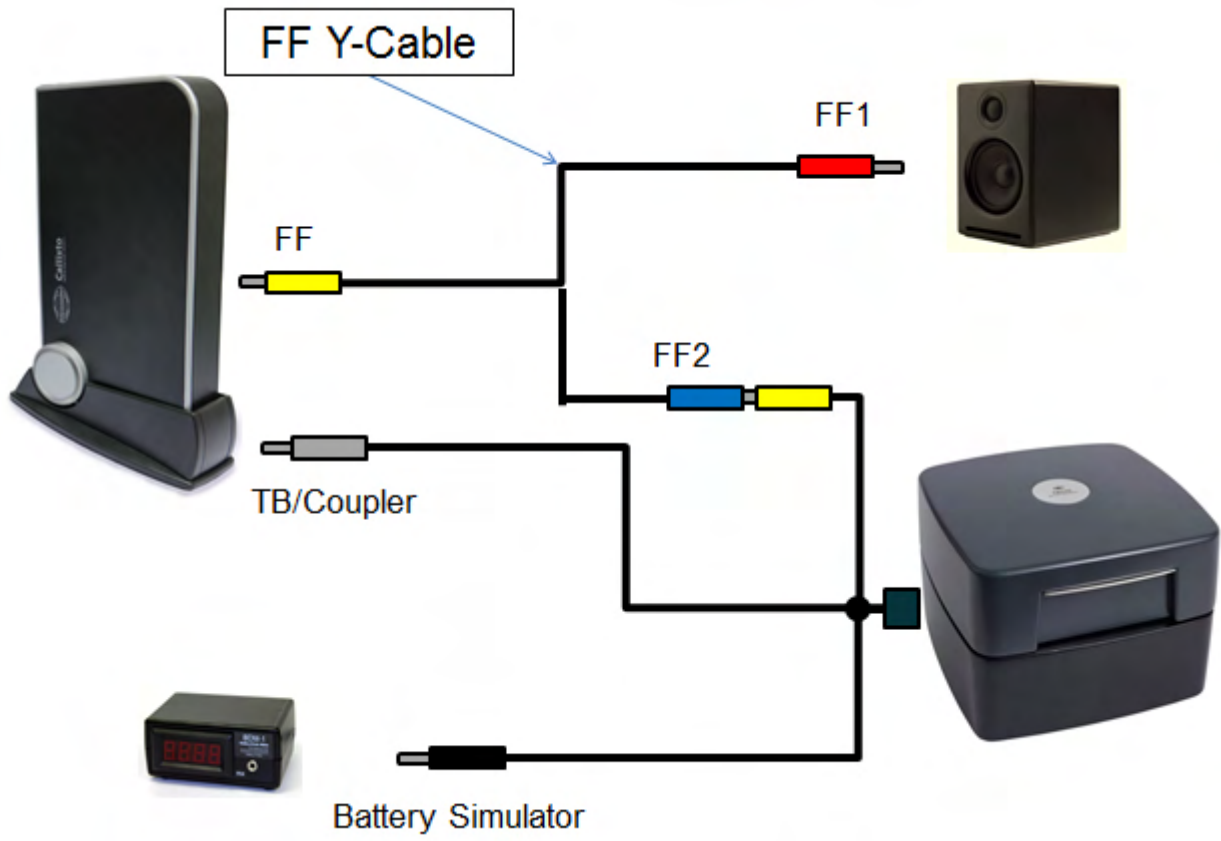







4 Printing and making reports

4.1 The print wizard

In the Print Wizard you have the option to create customized print templates which can be linked to individual protocols for quick printing. The Print Wizard can be accessed in two ways.

- If you want to make a template for general use, or select an existing one for printing: Go to **Menu/File/Print Layout...** in any of the Callisto™² Suite tabs (AUD, REM or HIT)
- If you want to make a template or select an existing one to link to a specific protocol: Go to Module tab (AUD, REM, or HIT) relating to the specific protocol and select **Menu/Setup/AC440 setup**, **Menu/Setup/REM440 setup**, or **Menu/Setup HIT440 setup**. Select the specific protocol from the drop-down menu and select **Print Wizard** at the bottom of the window.

Now the **Print Wizard** window opens and shows the following information and functionalities:

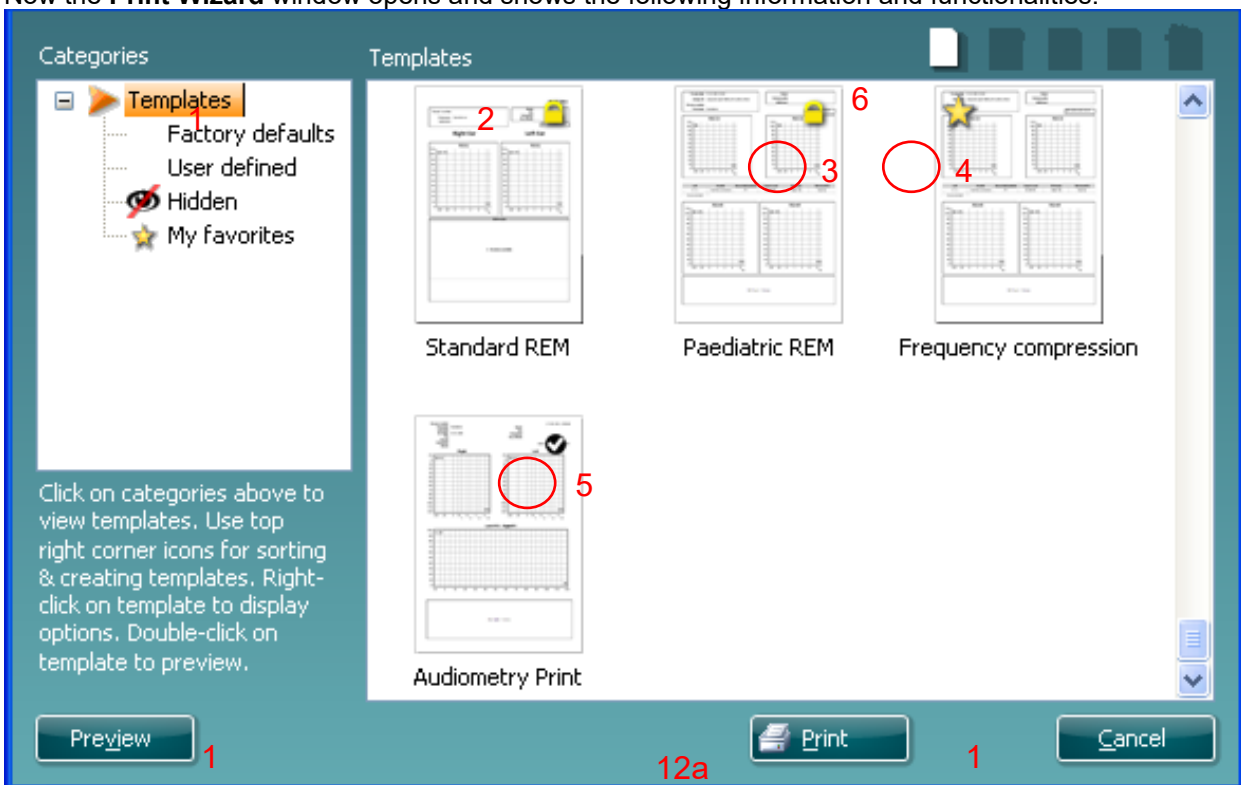

12b 

- Underneath **Categories** you can select
 - Templates** to show all available templates
 - Factory defaults** to show only standard templates
 - User defined** to show only custom templates
 - Hidden** to show hidden templates
 - My favourites** to show only templates marked as a favourite
- Available templates from the selected category are shown in the **Templates** viewing area.



3. Factory default templates are recognized by the lock icon. They ensure that you always have a standard template and do not need to create a customized one. However, they cannot be edited according to personal preferences without resaving with a new name. **User defined**/created templates can be set to **Read-only** (showing the lock icon), by right clicking on the template and selecting **Read-only** from the drop down list. **Read-only** status can also be removed from **User defined** templates by following the same steps.
4. Templates added to **My favorites** are marked with a star. Adding templates to **My favorites** allows quick viewing of your most commonly used templates.
5. The template that is attached to the selected protocol when entering the print wizard via the **AC440**, **REM440** or **HIT440** window is recognized by a checkmark.
6. Press the **New Template** button to open a new empty template.
7. Select one of the existing templates and press the **Edit Template** button to modify the selected layout.
8. Select one of the existing templates and press the **Delete Template** button to delete the selected template. You will be prompted to confirm that you want to delete the template.
9. Select one of the existing templates and press the **Hide Template** button to hide the selected template. The template will now be visible only when **Hidden** is selected under **Categories**. To unhide the template, select **Hidden** under **Categories**, right click on the desired template and select **View/Show**.
10. Select one of the existing templates and press the **My Favorites** button to mark the template as a favorite. The template can now be quickly found when **My Favorites** is selected under **Categories**. To remove a template marked with a star from My Favorites, select the template and press the **My Favorites** button.
11. Select one of the templates and press the **Preview** button to print preview the template on screen.
12. Depending how you reached the Print Wizard, you will have the option to press
 - a. **Print** for using the selected template for printing or press
 - b. **Select** for dedicating the selected template to the protocol from which you got into the Print Wizard.
13. To leave the Print Wizard without selecting or changing a template press **Cancel**.

Right clicking on a specific template provides a drop-down menu offering an alternative method for performing the options as described above:

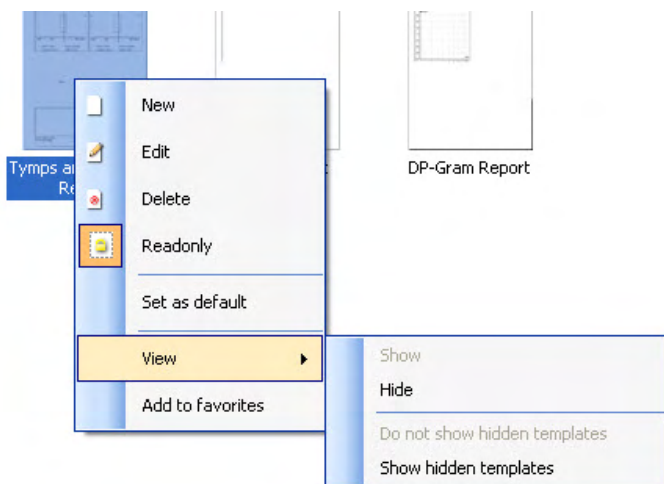





4.1.1 Designing a customized print template

After clicking on the **New Template** (or **Edit Template**) button the design window shows as below.

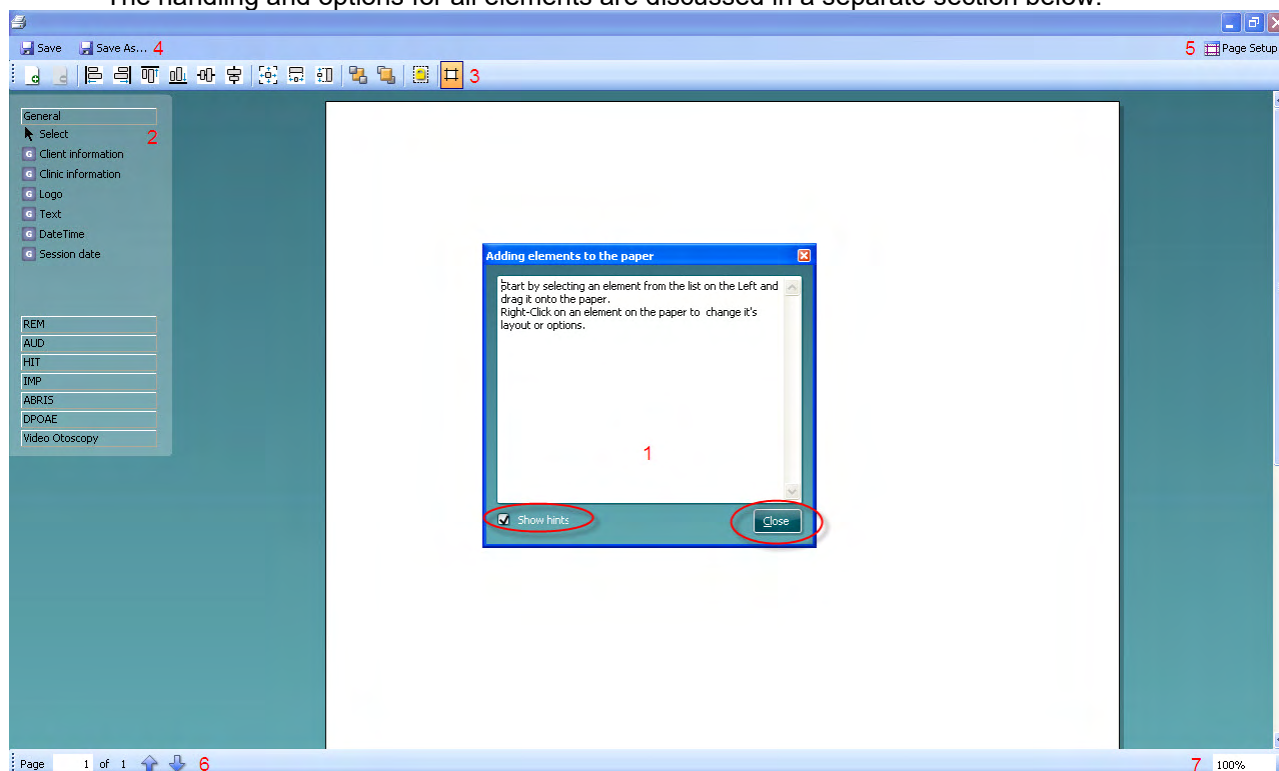
1. Upon opening, a short description about how to create a template will show on the screen. Press **Close** to close the message box. Uncheck the **Show hints** checkbox if you do not want it to appear next time.
2. This list shows the elements which can be dragged onto the blank template. When **General** is selected, the general elements are listed. Template elements for each module will be listed when selecting the relevant module name, for example **AUD, REM, HIT**. If other suites are installed, such as the Titan suite, the relevant suites will also be displayed.
The handling and options for all elements are discussed in a separate section below.



3. The taskbar includes numerous icons for customizing the elements that are dragged onto the blank template page. These are described below in a separate section.
4. Press **Save** to save the print template and go back to the **Print Wizard** window. If you have created a new template, you are prompted to give it a name. Press **Save As...** if you have modified an existing template and want to save under a different name.
5. Pressing the **Page Setup** button opens the **Page Setup** window where you can choose the paper size, source, margins, and setup the paper orientation.
6. If the template has more than one page, use the up and down arrows, , to scroll through the different pages. You can also type in the page number that you would like to view and/or edit.
7. The **Zoom** drop down menu allows you to change the viewing size of the template on screen.



4.1.2 Design elements

Template elements are added to the template page using the select, drag, and drop function. Click on the desired element and drag it onto the template page. The element will appear as a small box in the upper left-hand corner. Resize the element to the desired size and drag it to an appropriate location. The following elements are available for the **AUD**, **REM**, **HIT** and **Video Otoscopy** modules. The section below describes the options available within each element once dragged onto the template. Right clicking on any element will list its options for customization.

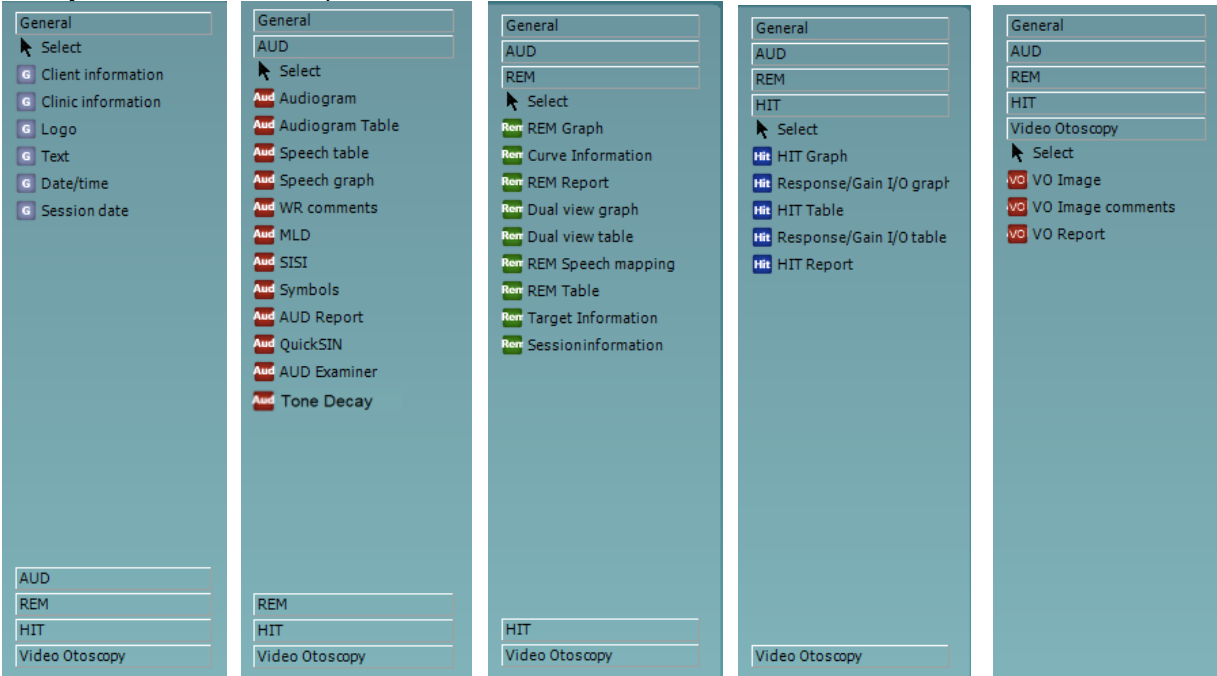

4.1.2.1 General elements

1. Client information

- Select fields** opens the **Select fields** window where you select which items are to be shown in the client information element. You can change the order of the items by selecting one and pressing the up or down arrows . Pressing will create a new empty field that can be named and shown in the template. Change a field's name by selecting it, waiting for 1 sec, and then left clicking on the name. Pressing will remove user created fields when selected. Press to restore the manufacturers' default fields.
- Format...** opens the **Format Client** window. Here you can change the the font, font size and formatting, and the appearance (borders) of the **Client information** area.
- Selecting **Rotate** makes the element rotate 90

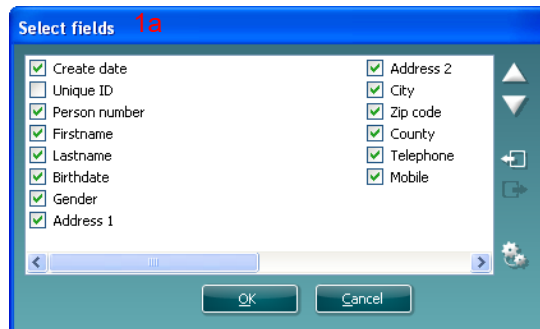
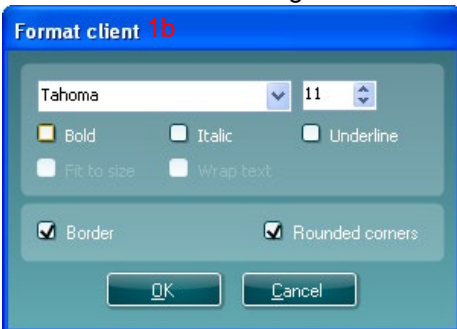

2 Clinic information.



- a. **Select fields** pops up the **Select fields** window where you select which items are to be shown in the clinic information element. You can change the order of the items by selecting one and pressing the up or down arrows . Pressing will create a new empty field that can be named and shown in the template. Change a field's name by selecting it, waiting for 1 sec, and then left clicking on the name. Pressing will remove user created fields when selected.
Press to restore the manufacturers' default fields.
- b. **Enter clinic info...** opens the **Clinic info editor** window. Here you can type and save the clinic information specifically for the selected print template. The **Create date** item cannot be changed as it will always show the current date and time.
- a. **Format...** Here you can change the the font, font size and formatting, and the appearance (borders) of the **Clinic information** area.
- c. By selecting **Show labels**, the **Clinic information** fields can be toggled on and off.
- d. Selecting **Rotate** makes the element rotate 90 degrees clockwise.

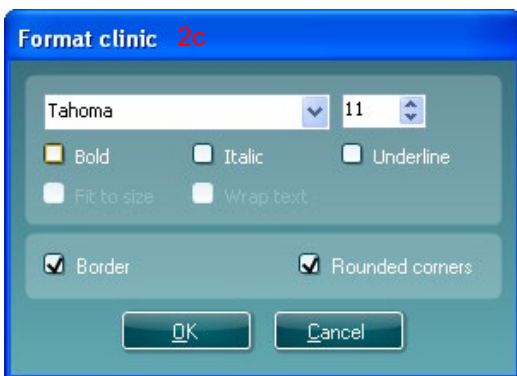
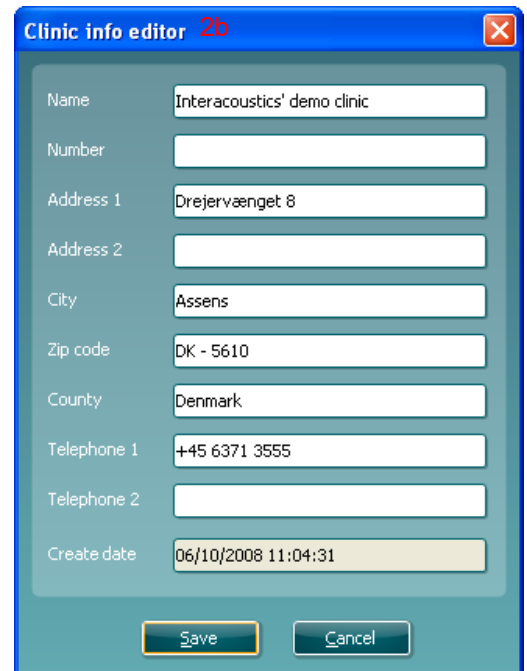
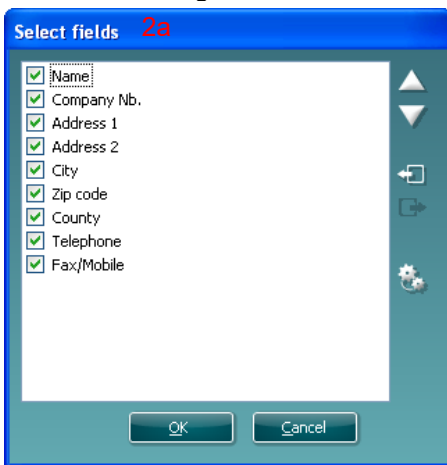

3. Logo.

- a. **Select image** opens a window from where you can browse to find the image stored on your PC that you want to include in the template.
- b. Selecting **Rotate** makes the element rotate 90 degrees clockwise.

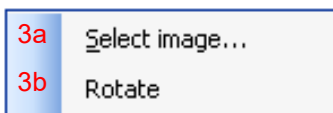

3. Text. This element allows you to add additional text, e.g., footnotes on your template.

- a. **Enter text** opens the **Enter Text** window. Here you can type in freetext and choose the font type, size and formatting.
- b. Selecting **Rotate** makes the element rotate 90 degrees clockwise.



- 4a Enter text
- 4b Rotate

4. **Date Time.** This element allows you to put in a stamp on the template showing date and/or time of printing.
 - a. **Enter setup...** opens the **Date Time setup** window. Here you choose the format in which the date and/or time appears in the template. You can also choose the font type, size and formatting.
 - b. Selecting **Rotate** makes the element rotate 90 degrees clockwise.

- 5a Enter setup...
- 5b Rotate

5. **Session date.** This element allows you to put in a stamp on the template showing date and/or time that the measurements were recorded.
 - a. **Enter setup...** opens the **Date Time setup** window, exactly as in 5a. Here you choose the format in which the date and/or time appears in the template. You can also choose the font type, size and formatting.
 - b. Selecting **Modules** gives the opportunity to define which modules' session dates will be shown. On the print out you can combine measurements from both the Callisto™ Suite and Titan Suite.
 - c. **Toggle borders** allows you to disable or enable the border around the **Session date** element.



d. Selecting **Rotate** makes the element rotate 90 degrees clockwise.

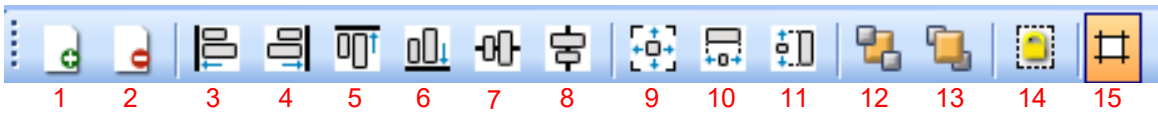



- 6a Enter setup...
- 6b Modules...
- 6c Toggle border
- 6d Rotate

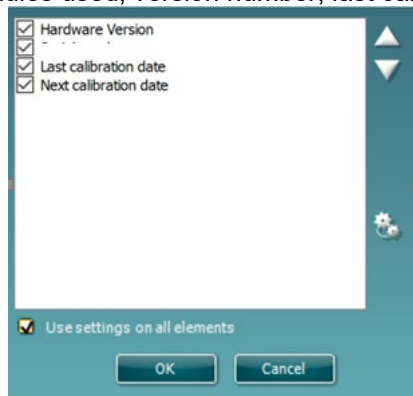

6. **Hardware** – Here you can include information about the hardware such as Hardware name, modules used, version number, last calibration date and next calibration due.



a. **Select fields** pops up the **Select fields** window where you select which items are to be shown in the Hardware element. You can change the order of the items by selecting one and pressing the up  or down arrows . Press  to restore the manufacturers' default fields.

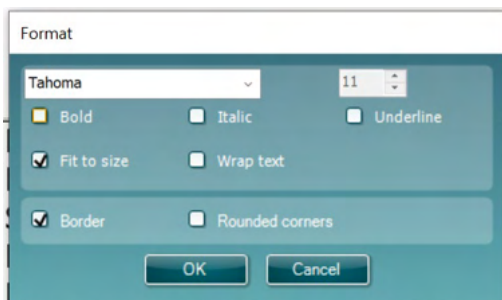

- b. **Format...** Here you can change the the font, font size and formatting, and the appearance (borders) of the **Hardware** area
- c. Selecting **Modules** gives the opportunity to define which modules' session dates will be shown
- d. Selecting **Rotate** makes the element rotate 90 degrees clockw

4.1.3 Taskbar

1. **Add page** to make a template of more than one page.
2. **Remove page.** You will be prompted if you are sure you want to delete the page and all its contents.
3. **Align left.** If you select two or more elements (using the shift button on the keyboard) this button will align those elements on their left sides.
4. **Align right.** If you select two or more elements (using the shift button on the keyboard) this button will align those elements on their right sides.
5. **Align top.** If you select two or more elements (using the shift button on the keyboard) this button will align those elements on their top sides.
6. **Align bottom.** If you select two or more elements (using the shift button on the keyboard) this button will align those elements on their bottom sides.
7. **Align horizontal.** If you select two or more elements (using the shift button on the keyboard) this button will align those elements on their horizontal central axis.
8. **Align vertical.** If you select two or more elements (using the shift button on the keyboard) this button will align those elements on their vertical central axis.
9. **Make equal size.** If you select two or more elements (using the shift button on the keyboard) this button will make all sizes equal to the element that was placed on the page first.
10. **Same width.** If you select two or more elements (using the shift button on the keyboard) this button will make all widths equal to the width of the element that was placed on the page first.
11. **Same height.** If you select two or more elements (using the shift button on the keyboard) this button will make all heights equal to the height of the element that was placed on the page first.
12. **Send to back.** This button sends the selected element(s) to the back.
13. **Send to front.** This button sends the selected element(s) to the front.
14. **Lock element** locks (or unlocks) the selected element(s). This means that the position and size of the element is locked. When one of the taskbar functions is used on a locked element it will automatically unlock.
15. **Display margins** toggles between showing and not showing the print margins as a broken line.



4.2 Creating reports

The Callisto™ 2.0 Suite allows electronically generated reports through the **Report editor**. This allows reports to be saved in the module for each session and they can be retrieved at any time. The reports can also be implemented in the patient's printout, which gives you the opportunity to have all the relevant test information in one customized piece of paper. The report function also includes the possibility to make **Report templates** which gives you the option to have different templates e.g., for different client groups or for use by different clinicians.

Note: You must enter the report whilst in the current client session. It is not possible to enter a report for a previous session unless you transfer it to the current session first and resave it. Please refer to 1.10 on transferring data to current sessions (Menu/Edit/Transfer to current session).

4.2.1 Operation of the report editor

To open the **Report editor** to make a report on the current patient you need to press  in the **AUD**, **REM**, or **HIT** screen.

4.2.1.1 The report editor

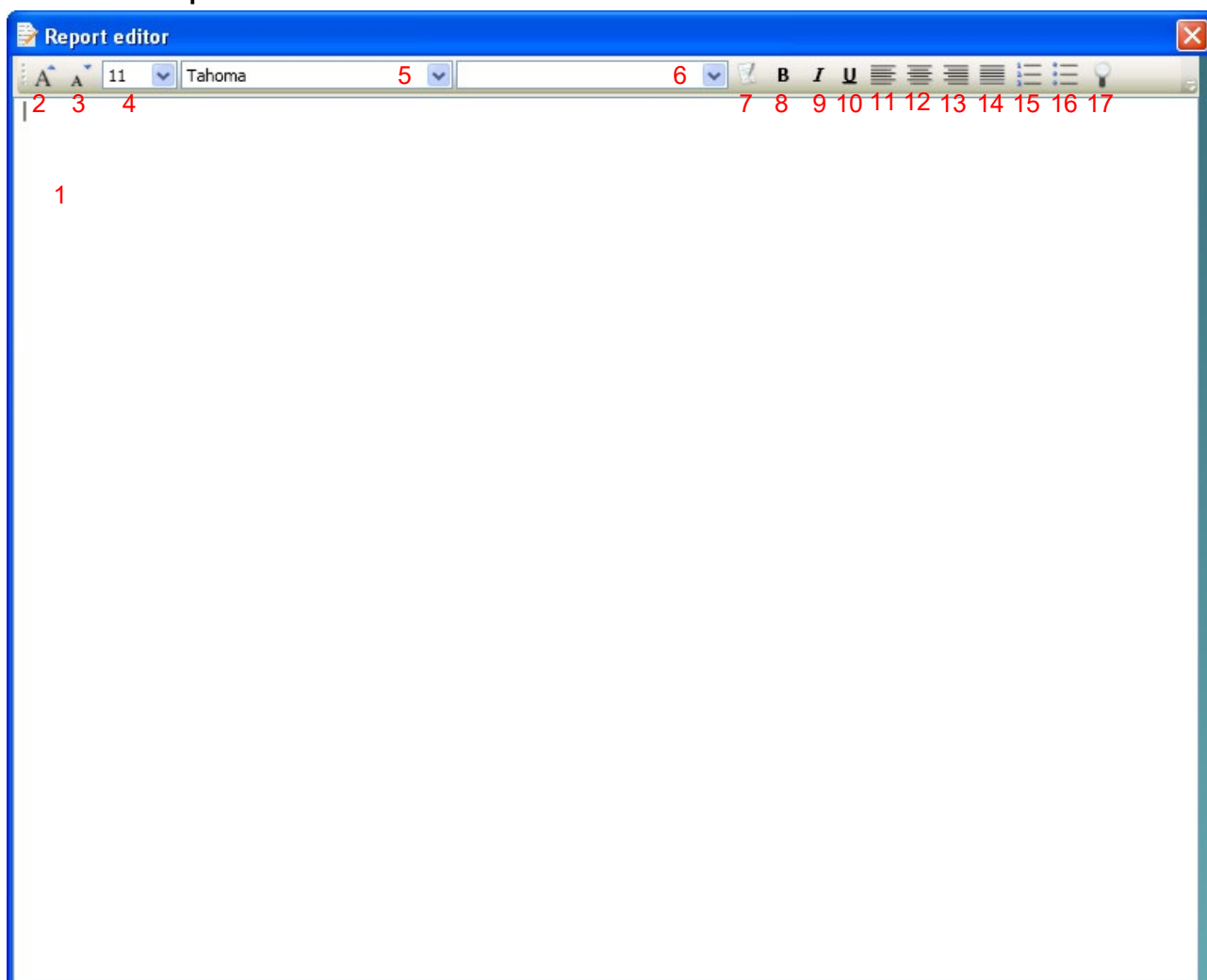





1. Write your reports and observations in the report page.
2. Increase the **Font size** of the current selection.
3. Decrease **Font size** of the current selection.
4. Change the **Font size** of the current selection.
5. Change the **Font type** of the current selection.
6. Select a **Template** from one of the existing templates in the drop-down menu and insert it in the current report.
7. **Template Editor** allows you to create a new template, edit an existing template, or set a preferred template to be default template (see section 4.2.1.2).
8. Change the font of the current selection to be **Bold**.
9. Change the font of the current selection to be **Italic**.
10. Change the font of the current selection to be **Underlined**.
11. Change the alignment of the selection to **Align left**.
12. Change the alignment of the selection to **Centre**.
13. Change the alignment of the selection to **Align right**.
14. Change the alignment of the selection to **Justify**.
15. Insert **Numbering**
16. Insert **Bulleting**.
17. **Import Image** allows you to browse for a picture on your PC (e.g., a clinic logo).

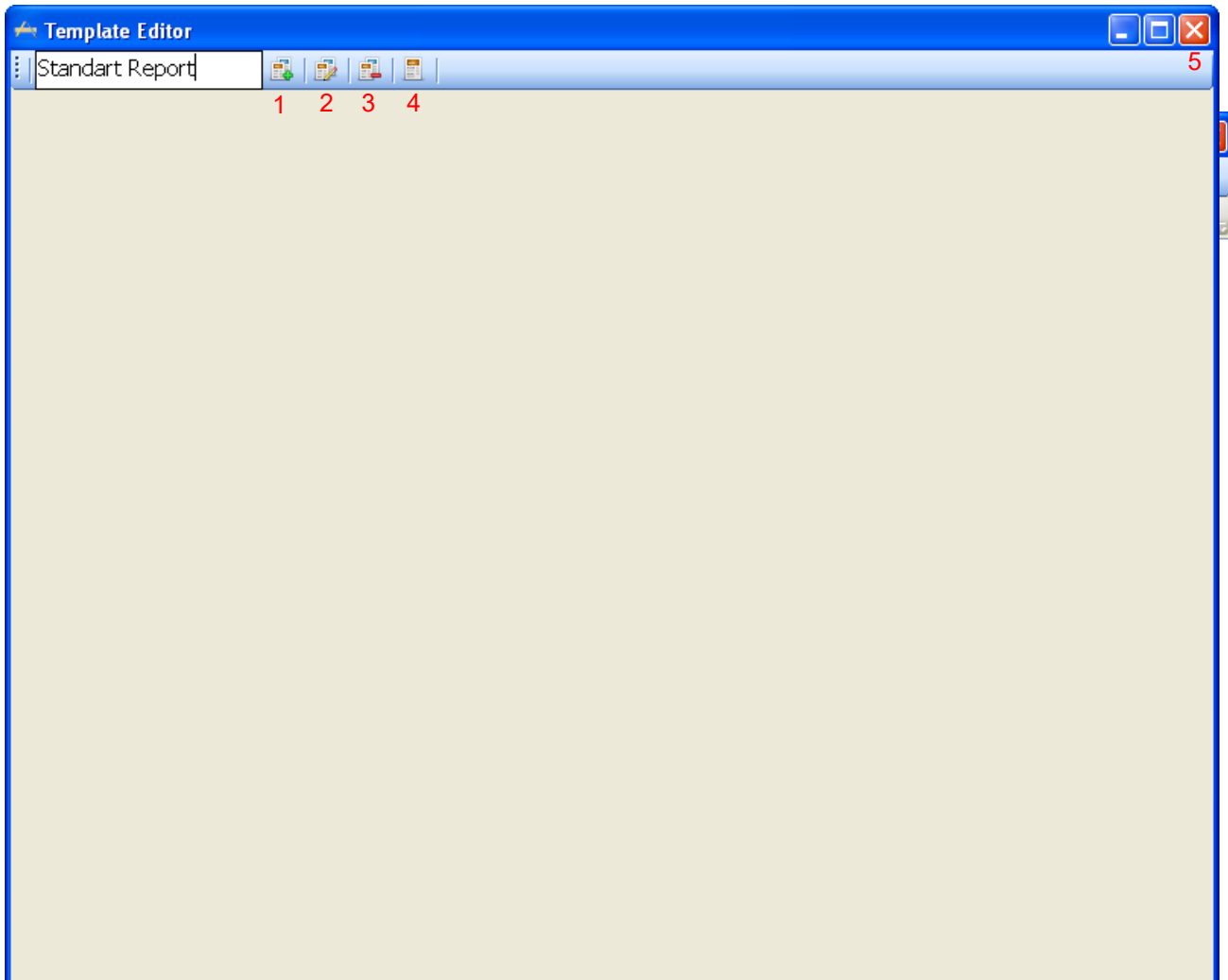

4.2.1.2 The template editor

To enter the **Template editor** press .



1. **New Template** enables you to create a new customized report template. Enter a template name (e.g., “Standard Report”) before pressing **New Template**. The name of the template will then appear on the tool bar, and you can type in your report template details like in the example below.
Remember to press the **Save** icon to save the template when finished .
2. **Edit Template** allows you to edit an existing template. Press the button and select which of the saved templates you wish to adjust.
3. **Delete Template** allows you to remove an existing template. Press the button and select which of the saved templates you wish to delete.
4. **Set as Default Template** will cause the currently open template always to be inserted when the report editor is opened for the first time during a session.
5. Press the red cross to return to the Report Editor .



5 Recovery manager

In the unlikely event that your software is not shut down properly, the recovery manager will ensure that no data is lost. During testing each threshold or measurement that is stored on screen is also saved in a log file on your PC. When you enter one of the modules of the Equinox/Callisto™ Suite it checks if this log file contains data that may need recovering.

The audiometry module will show the following screen in which you can indicate which of the test results need recovering.

Recovery Manager

Client information

First name: Standalone

Last name:

Recovery data

Recover MLD test data

Recover Speech test data

Recover QuickSin test data

Recover Tone test data

Recover SISI test data

Recover Weber test data

Recover AUD report data

Select all Deselect all

All data not recovered will be deleted!

Cancel Recover selected data

In the REM and HIT module the recovery manager shows the following screen which allows you to recover all available measurements.

Recovery Manager

Recovery data for client

First name: Standalone

Last name:

It appears that the Suite closed incorrectly and left unsaved data.
Do you want to recover this data ?

Yes No

Note that in case the current selected patient is different from the patient on which earlier measurements took place, the recovery manager will warn you.





6 Crash reports

The crash report helps software developers better understand software behaviour if it suddenly crashes. The reports can either be saved and emailed or they can be sent directly into a Crash Report database, to which software engineers have access and subsequently investigate the incidents.

If the Callisto™ Suite crashes and the details can be logged by the system; the Crash Report window will appear on the test screen (as shown below). The crash report provides information to Interacoustics about the error message and extra information can be added by the user outlining what they were doing before the crash occurred to assist in fixing the problem. A screen shot of the software can also be sent.

The “I agree to the Exclusion of Liability” check box must be checked before the crash report can be sent via the internet. For those users without an internet connection, the crash report can be saved to an external drive so it can be sent from another computer with an internet connection.





7 Quick guides

Several quick guides have been developed to support the users of the Callisto™, these can be found in your software by navigating to 'Manuals and Guides' in all modules of the software.

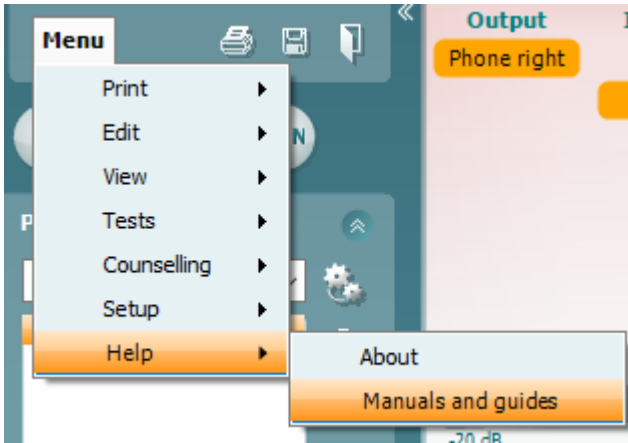

These quick guides involve the following topics:

- Introduction to Quick Guides
- Basic Audiometry
- AC440 Protocol Setup
- Print Report
- Customised Printout Setup
- TEN Test
- QuickSIN
- ANL Test
- SIQ Test
- SIN Test
- A Beginners Guide to Real Ear Measures
- REM BSA
- REM440 Protocol Setup
- Directionality REM440Binaural REM
- RECD
- Visible Speech Mapping
- HIT440 Instructions
- HIT440 Protocol Setup
- ACT quick guide
- CROS BiCROS
- Frequency lowering



8 References

British Society of Audiology Recommended Procedure: Pure tone air and bone conduction threshold audiometry with and without masking and determination of uncomfortable loudness levels (2004). Uploaded from www.thebsa.org.uk/docs/bsapta.doc

Carhart. R. (1957): *Clinical determination of abnormal auditory adaptation*. In: *Archives of Otolaryngology*. 65, p.32-39.

Ching TYC, Scollie SD, Dillon H and Seewald R (2010). A cross-over, double-blind comparison of the NAL-NL1 and the DSL v4.1 prescriptions for children with mild to moderately severe hearing loss. *Int J Audiol* 49(S1): 4-15.

Dillon, H. 2001 *Hearing Aids*. Thieme. Boomerang Press Sydney

Dillon H., Keidser G, Ching T, Flax M, Brewer S (2010) The NAL-NL2 prescription procedure. http://hearing.siemens.com/resources-re/files/01-professional/05-audiology/02-knowledge-sharing/NAL-NL2_prescriptio-procedure_2010_04.pdf

Keidser G and Dillon H (2006). What's new in prescriptive fittings Down Under? In Palmer CV, Seewald R (Eds.), *Hearing Care for Adults 2006*. Phonak AG, Stafa, Switzerland, pp133-142

Keidser G, O'Brien A, Carter L, McLelland M, Yeend I. (2008). Variation in preferred gain with experience for hearing aid users. *Int J Audiol*, 47(10):621-635.

Kuk F, & Ludvigsen C. (2003). Changing with the Times: Choice of Stimuli for Hearing Aid Verification. *Hearing Review*, August 2003.

Fabry D. (2004) Real Ear Measurements and Digital Hearing Aids: Realities, Myths, and Measurement Techniques. *Phonak Focus* no. 32. (www.phonak.com)

Holube, I & EHIMA-ISMADHA working group (2007) Short description of the International Speech Test Signal (ISTS). Centre of Competence HörTech and Institute of Hearing Technology and Audiology, Oldenburg, Germany

http://www.icra.nu/Prod_Noise.html

Katz J. (2002) *Handbook of Clinical Audiology*, Fifth Edition. Lippincott Williams & Wilkins

Nielsen H. & Carver K. R. (1997) *Håndbog i Audiologiske Tests*. Phonak Danmark

Pumford, J. & Sinclair, S. (2001) Real-Ear Measurement: Basic Terminology and Procedures. *Audiology Online*

Stach, B. A. (1998) *Clinical Audiology an Introduction*. Singular Publishing Group San Diego, Thomson Learning

Sullivan R. F. (1988) Probe tube microphone placement near the tympanic membrane. *Hearing Instruments*, vol. 39, No. 7, pp 43 – 60.



Nabelek, A.K., Tucker, F.M., & Letowski, T.R. (1991). Toleration of background noises: Relationship with patterns of hearing aid use by elderly persons. *Journal of Speech and Hearing Research*, 34, 679-685.

Nabelek, A., Freyaldenhoven, M., Tampas, J., & Burchfield, S. (2006). Acceptable noise level as a predictor of hearing aid use. *Journal of the American Academy of Audiology*, 17(9), 626-639.

Mehta and Singh. (2000). Screening Tests for Non-Organic Hearing Loss. [online] Available at: <http://medind.nic.in/maa/t00/i1/maat00i1p79.pdf> [Accessed 8 Mar. 2017].

National Research Council (US) Committee on Disability Determination for Individuals with Hearing Impairments; Dobie RA, Van Hemel S, editors. *Hearing Loss: Determining Eligibility for Social Security Benefits*. Washington (DC): National Academies Press (US); 2004. 3, Assessment of the Auditory System and Its Functions. Available from: <https://www.ncbi.nlm.nih.gov/books/NBK207835/> [Accessed 8 Mar. 2017].

Schoepflin, J. (2012). Back to Basics: Speech Audiometry Janet R. Schoepflin. [online] *AudiologyOnline*. Available at: <http://www.audiologyonline.com/articles/back-to-basics-speech-audiometry-6828> [Accessed 8 Mar. 2017].

Taylor, B. (2003). Speech in noise tests: How and why to include them in your test battery. [online] Available at: <https://www.etymotic.com/media/publications/erl-0077-2003.pdf> [Accessed 7 Mar. 2017].

Marrone, N., Mason, C. and Kidd, G. (2008). Evaluating the Benefit of Hearing Aids in Solving the Cocktail Party Problem. *Trends in Amplification*. 12(4): 300–315